

167D Series Switching Valves



P1185

TYPE 167D TWO-WAY SWITCHING VALVE



P1184

TYPE 167DA THREE-WAY SWITCHING VALVE

Figure 1. 167D Series Switching Valves

Introduction

The 167D Series switching valves are typically used to deliver constant reduced pressure of gaseous fluids to pilot-operated controllers and other pneumatic instrumentation.

- The Types 167D and 167DS are two-way switching valves.
- The Types 167DA and 167DAS are three-way switching valves.

Features

- **Compact**—The Types 167D and 167DA switching valves are engineered for outstanding performance in a compact, lightweight package.
- **Easy, Accurate Adjustment**—With a choice of springs for optimum resolution, the switching point is set to a specific requirement by an adjusting screw atop the spring case.
- **Sour Gas Service Capability**—NACE MR0175 and MR0103 compliant construction available.
- **Optional Stainless Steel Construction**—The Types 167DS and 167DAS provide high resistance to corrosion especially beneficial for offshore applications.
- **Ease of Maintenance**—No special tools are required to perform maintenance, and all maintenance can be performed with the valve in the line.
- **Rugged Construction**—The Types 167D and 167DA switching valves are engineered for longer service life with minimal maintenance requirements.
- **Corrosion Resistant Fasteners**—Bolting and adjusting screw are double zinc-chromated for enhanced corrosion resistance. Optional stainless steel bolting and adjusting screw are also available.



www.fisher.com



Specifications

Available Configurations

Types 167D and 167DS: Two-way switching valves

Types 167DA and 167DAS: Three-way switching valves

Body Size, Inlet, and Outlet Connection Style

Ports A and C: 1/4 or 1/2 NPT

Vent and Control Pressure Connections (Port D) and Port B: 1/4 NPT

Construction Materials

See Table 4

Maximum Operating Inlet Pressure⁽¹⁾

Types 167D and 167DS: 400 psig / 27,6 bar

Types 167DA and 167DAS: 125 psig / 8,6 bar

Types 167DA and 167DAS (NACE): 100 psig / 6,9 bar

Set Pressure Ranges

See Tables 1 and 2

Maximum Diaphragm Pressure⁽¹⁾

150 psi / 10,3 bar over outlet pressure setting up to a maximum of 250 psi / 17,2 bar

Flow and Sizing Coefficients

See Table 3

Spring Case Vent Location

Aligned with inlet standard, other positions optional

Temperature Capabilities⁽¹⁾

Nitrile (NBR)

Standard Service (Types 167D and 167DA only):

-20° to 180°F / -29° to 82°C

Low Temperature Service (Types 167D and 167DA only) and Standard Service (Types 167DS and 167DAS only):

-40° to 180°F / -40° to 82°C

Fluorocarbon (FKM)

High Temperature Service: 0° to 300°F /

-18° to 149°C

Approximate Weights

Types 167D and 167DA: 1.2 pounds / 0,5 kg

Types 167DS and 167DAS: 2.8 pounds / 1 kg

Options

Types 167D and 167DA

- Handwheel adjusting screw
- Fluorocarbon (FKM) diaphragm, soft seat, and O-rings
- Stainless steel valve stem and plug. Includes stainless steel seat.
- 1-hole panel mount with handwheel adjusting screw and 1/4 NPT tap spring case
- 3-hole panel mount bonnet with handwheel adjusting screw and 1/4 NPT spring case
- 1/4 NPT tapped vent spring case
- 1/4 NPT tapped vent and closing cap
- Adjusting screw with locknut and a lock wire to one flange bolt (For Type 167D only)
- Panel mounting bracket. Includes 1/4 NPT spring case, standard adjusting screw, nut, and bracket.
- Yoke mounting bracket. Includes 1/4 NPT spring case, standard adjusting screw, nut, fasteners, and bracket.
- Size 30-70 casing mounting bracket. Includes 1/4 NPT spring case, standard adjusting screw, nut, fasteners, and bracket
- NACE MR0175 or NACE MR0103 construction⁽²⁾

Types 167DS and 167DAS

- Handwheel adjusting screw
- Fluorocarbon (FKM) diaphragm, soft seat, and O-rings
- 1-hole panel mount with handwheel adjusting screw and 1/4 NPT tap spring case
- Panel mounting bracket. Includes 1/4 NPT spring case, standard adjusting screw, nut, and bracket.
- Yoke mounting bracket. Includes 1/4 NPT spring case, standard adjusting screw, nut, fasteners, and bracket.
- Size 30-70 casing mounting bracket. Includes nut, fasteners, and bracket.

1. The pressure/temperature limits in this Bulletin and any applicable standard or code limitation should not be exceeded.

2. Product complies with the material requirements of NACE MR0175 or MR0103. Environmental limits may apply.

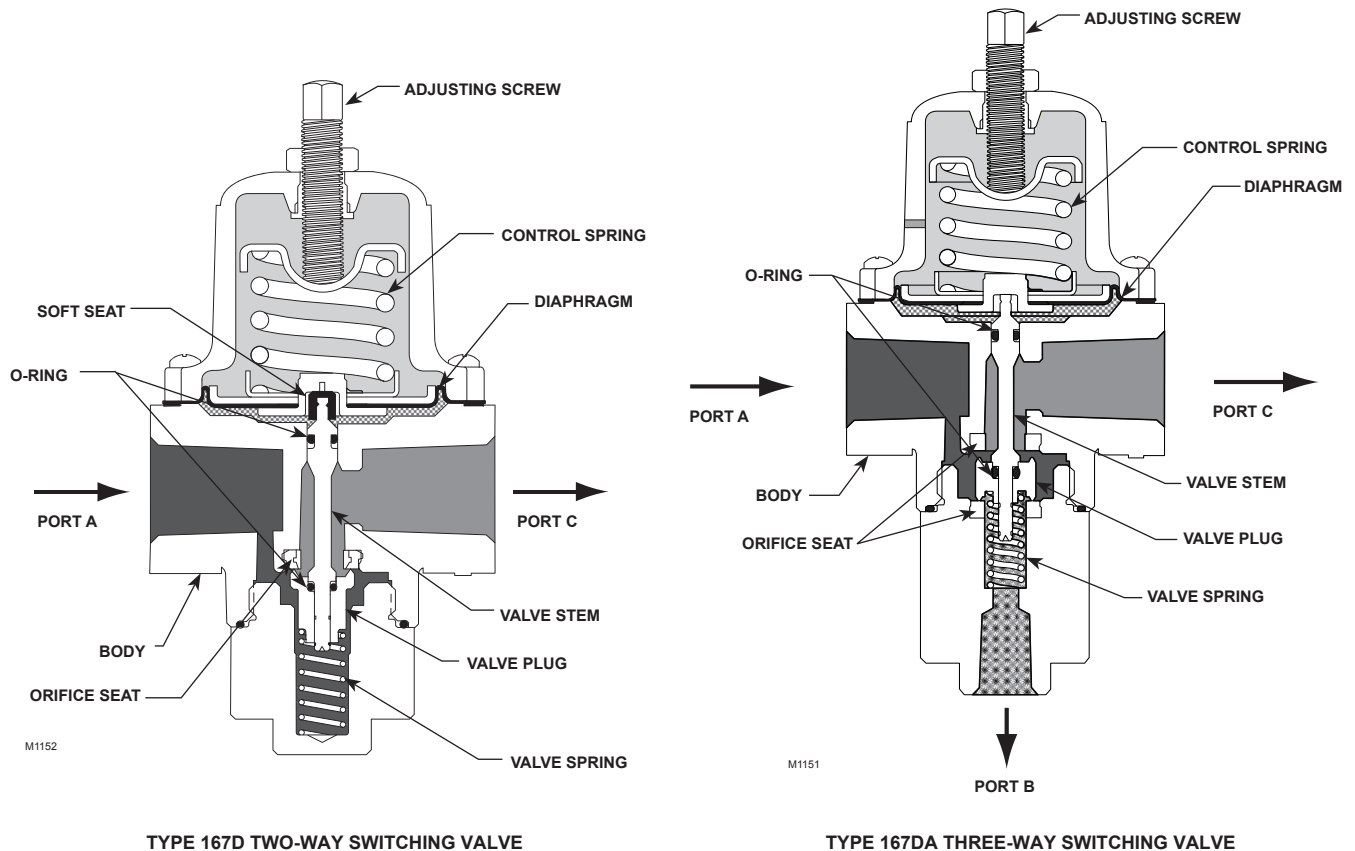

INLET PRESSURE
 OUTLET PRESSURE (WHEN LOADING PRESSURE IS LESS THAN SETPOINT)
 OUTLET PRESSURE (WHEN LOADING PRESSURE IS EQUAL TO OR GREATER THAN SETPOINT)
 ATMOSPHERIC PRESSURE
 LOADING PRESSURE

Figure 2. 167D Series Operational Schematics (Port D not shown)

Principle of Operation

Refer to Figure 2 and also refer to Figures 3 through 5 for port D location. Control pressure enters the switching valves through Port D (not shown in Figure 2) and registers under the diaphragm. Control pressure overcomes the spring force and the diaphragm, and raises the valve plug, closing port C and opening port B of the Type 167DA three-way switching valve. In this condition, the Type 167D construction is turned off and the Type 167DA construction provides flow from path A to B. If, either intentionally or through pneumatic failure, the control pressure drops below the spring force, the diaphragm and valve plug move downward, opening port C and closing port B of the Type 167DA three-way switching valve. In this condition both constructions provide a flow path from port A to port C. The pressure change necessary to switch the valve depends on the spring used and the setting of the adjusting screw on the switching valve.

Installation

The switching valve can be mounted in any position, providing the vent in the spring case is free from obstruction. Connect the pneumatic control line to the port marked "D" on the valve body. Ports A and C (and B on the Types 167DA and 167DAS valve) are connected for the desired switching valve response to loss or decrease in pneumatic pressure.

Figure 5 shows typical application of the Types 167DA and 167DAS switching valve. If the control valve inlet pressure falls below a predetermined setting, the on-off controller turns off control pressure to the switching valve. This causes the switching valve to bleed the control valve diaphragm pressure to atmosphere, closing the control valve. The control valve remains closed until the inlet pressure is restored to the desired setting.

Dimensions are shown in Figure 7.

Bulletin 71.7:167D

Table 1. Three-Way Switching Valves Set Pressure Ranges and Control Spring Data

TYPE	SET PRESSURE RANGE				CONTROL SPRING DATA						MAXIMUM PRESSURE CHANGE ON TO SHIFT FROM PORT B CLOSED TO PORT C CLOSED		
	Port A or C as Inlet		Port B as Inlet		Color Code	Material	Part Number	Wire Diameter		Free Length			
	psig	bar	psig	bar				Inch	mm	Inch	mm	psid	bar d
167DA	14 to 20 16 to 35	0,97 to 1,4 1,1 to 2,4	7 to 20 10 to 30	0,48 to 1,4 0,69 to 2,1	White stripe Purple stripe	Zinc-plated Music Wire	GE40282X012 GE40283X012	0.145 0.156	3,68 3,96	1,425	36,2	10 13	0,69 0,90
	25 to 60 40 to 125	1,7 to 4,1 2,8 to 8,6	25 to 50 40 to 90	1,7 to 3,4 2,8 to 6,2	Brown stripe Pink stripe	Chrome Silicon	GE40284X012 GE40345X012	0.172 0.207	4,37 5,26			17 35	1,2 2,4
167DAS	14 to 20 16 to 35	0,97 to 1,4 1,1 to 2,4	7 to 20 10 to 30	0,48 to 1,4 0,69 to 2,1	White Purple	Inconel® X-750	GE40320X012 GE40321X012	0.148 0.162	3,76 4,12	1,750	44,4	8 12	0,55 0,83
	25 to 60 40 to 125	1,7 to 4,1 2,8 to 8,6	25 to 50 40 to 90	1,7 to 3,4 2,8 to 6,2	Brown Pink		GE40322X012 GE40323X012	0.177 0.218	4,50 5,54			16 31	1,1 2,1

Table 2. Two-Way Switching Valves Set Pressure Ranges and Control Spring Data

TYPE	SET PRESSURE RANGE		CONTROL SPRING DATA						
	Port A as Inlet		Color Code	Material	Part Number	Wire Diameter		Free Length	
	psig	bar				Inch	mm	Inch	mm
167D	3 to 15 5 to 20 5 to 35	0,21 to 1,0 0,34 to 1,4 0,34 to 2,4	Yellow stripe White stripe Purple stripe	Zinc-plated Music Wire	GG00421X012 GE40282X012 GE40283X012	0.142 0.145 0.156	3,61 3,68 3,96	1,425	36,2
	25 to 60 40 to 125	1,7 to 4,1 2,8 to 8,6	Brown stripe Pink stripe	Chrome Silicon	GE40284X012 GE40345X012	0.172 0.207	4,37 5,26		
167DS	5 to 20 5 to 35	0,34 to 1,4 0,34 to 2,4	White Purple	Inconel® X-750	GE40320X012 GE40321X012	0.148 0.162	3,76 4,12	1,750	44,4
	25 to 60 40 to 125	1,7 to 4,1 2,8 to 8,6	Brown Pink		GE40322X012 GE40323X012	0.177 0.218	4,50 5,54		
	50 to 150	3,4 to 10,3	Gold		GE40324X012	0.234	5,94		

Table 3. Flow and Sizing Coefficients

TYPES	BODY SIZE	PORT	WIDE-OPEN FLOW COEFFICIENTS		C ₁	IEC SIZING COEFFICIENT
			C _g	C _v		X _t
167D, 167DS	1/4 NPT	C	41.46	1.09	37.56	0.89
	1/2 NPT		46.50	1.18	39.03	0.96
167DA, 167DAS	All sizes	B	27.79	0.96	28.74	0.52
	1/4 NPT	C	49.35	1.60	30.58	0.59
	1/2 NPT		58.86	1.81	32.22	0.66

Table 4. Construction Materials

PART NAME	TYPES	
	167D and 167DA	167DS and 167DAS
BODY AND SPRING CASE	Aluminum (ASTM B85/Alloy 380)	CF8M/CF3M Stainless steel
SPRING RETAINER	Aluminum	316L Stainless steel
UPPER SPRING SEAT	Zinc-plated steel	316 Stainless steel
DIAPHRAGM PLATE	Chromate conversion coated Aluminum	
CONTROL SPRING	Zinc-plated steel and Chrome Silicon	Inconel® X-750
VALVE STEM	Brass or 316L Stainless Steel	316L Stainless steel
VALVE PLUG		
VALVE SPRING	302 Stainless steel or Inconel® X-750 (NACE)	
DIAPHRAGM, O-RINGS, AND SOFT SEAT	Nitrile (NBR) or Fluorocarbon (FKM)	
BOLTING, ADJUSTING SCREW	Zinc-plated steel	Zinc-plated steel or 316 Stainless steel
HEXNUT	Zinc-plated steel or 316 Stainless steel	316 Stainless steel
HANDWHEEL	Zinc-plated steel screw with resin handwheel	

Inconel® is a mark owned by Special Metals Corporation.

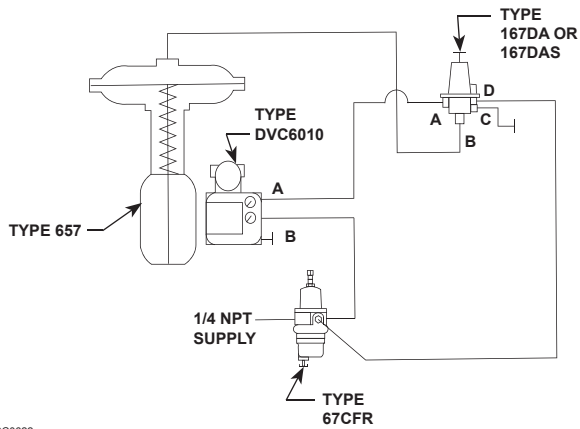

10C0622

Figure 3. Typical 167DA or 167DAS Installation
(Lockup system using Type 167DA or 167DAS to close air circuit to diaphragm of main valve in case of plant air failure. Main valve will remain in position it occupied at time of supply pressure failure.)

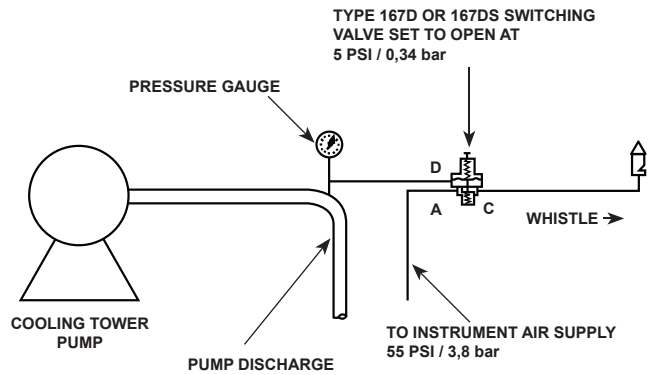

AF8400

Figure 4. Typical 167D or 167DS Installation
(Warning system using Type 167D or 167DS two-way valve to activate a whistle when pump discharge pressure falls.)

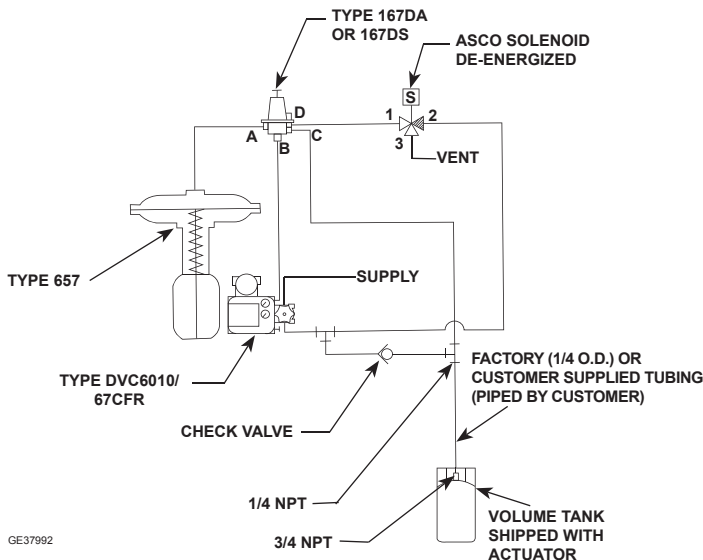

GE37992

Figure 5. Typical Switching Valve Application

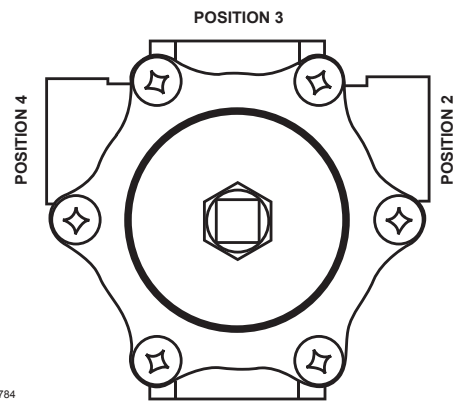

GE31784

POSITION 1 (ALIGNED WITH INLET) (STANDARD)

Figure 6. 167D Series Vent Positions

Overpressure Protection

The 167D Series switching valves have maximum outlet pressure ratings that are lower than their maximum inlet pressure ratings. A pressure-relieving or pressure-limiting device is needed if inlet pressure can exceed the maximum outlet pressure rating. Overpressuring any portion of a switching valve or associated equipment may cause leakage, parts damage, or personal injury due to bursting of pressure-containing parts or explosion of accumulated gas. Switching valve operation within ratings does not preclude the possibility of damage from external sources or from debris in the pipeline. A switching valve should be inspected for damage periodically and after any overpressure condition.

Universal NACE Compliance

Optional materials are available for applications handling sour gases. These constructions comply with the recommendations of all NACE International sour service standards.

The manufacturing processes and materials used by Emerson™ assure that all products specified for sour gas service comply with the chemical, physical, and metallurgical requirements of NACE MR0175 and/or NACE MR0103. Customers have the responsibility to specify correct materials. Environmental limitations may apply and shall be determined by the user.

Bulletin 71.7:167D

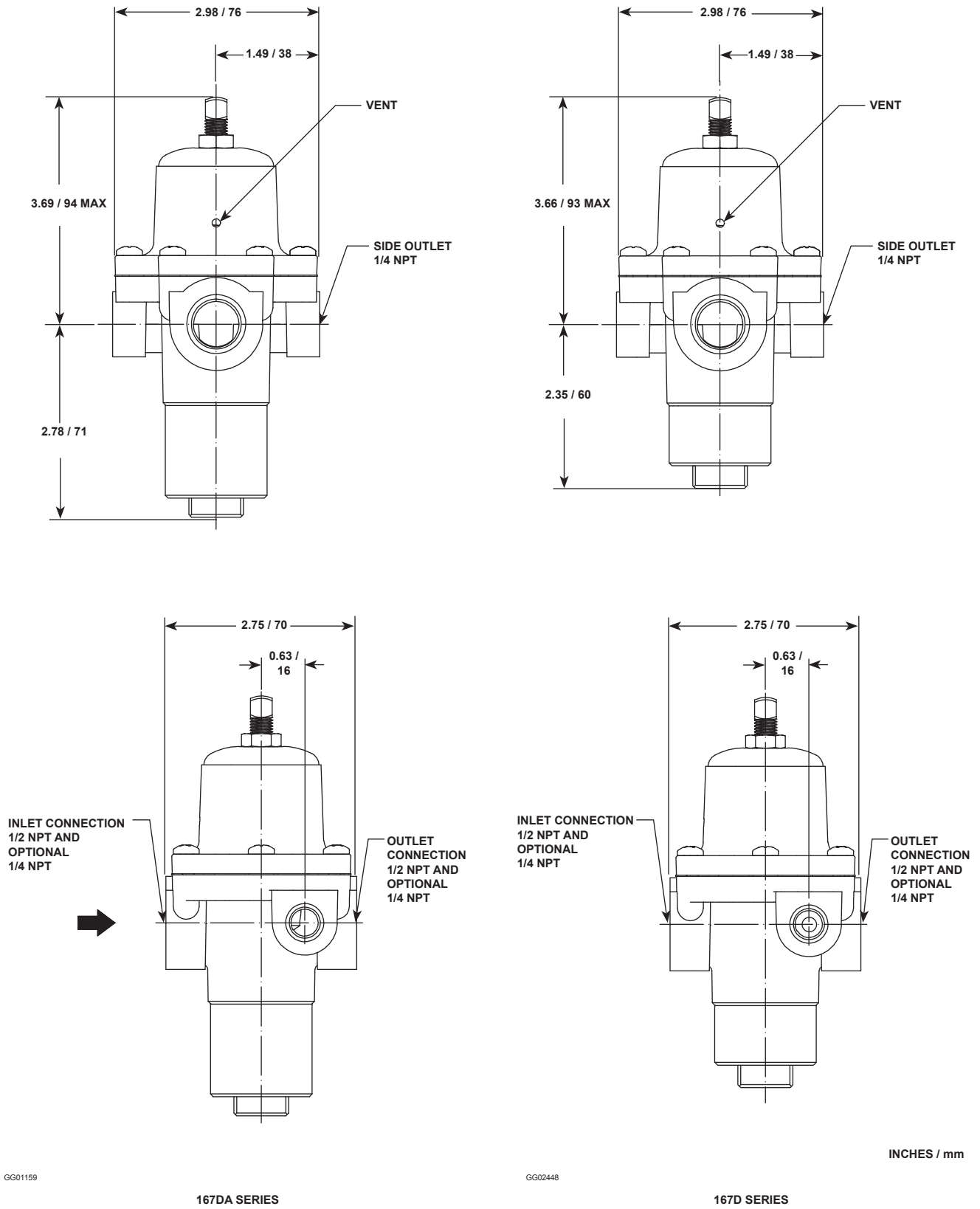

Figure 7. 167D Series Dimensions

Ordering Guide

Type (Select One)

- 167D (two-way, aluminum)***
- 167DS (two-way, stainless steel)***
- 167DA (three-way, aluminum)***
- 167DAS (three-way, stainless steel)***

Body Size (Ports A and C) (Select One)

- 1/4 NPT
- 1/2 NPT

Quantity (Specify) _____

Spring Case Style (Select One)

- Drilled hole vent (Types 167D and 167DA **standard**)***
- 1/4 NPT vent
(Types 167DS and 167DAS **standard**)***
- Single hole panel mount***

Adjusting Screw (Select One)

- Square head (Types 167D and 167DA **standard**)***
- Square head with closing cap
(Types 167DS and 167DAS **standard**)***
- Handwheel***

Set Pressure Range (Select One)

Three-Way Switching Valve

Port A or C as Inlet

- 14 to 20 psig / 0,97 to 1,4 bar***
- 16 to 35 psig / 1,1 to 2,4 bar***
- 25 to 60 psig / 1,7 to 4,1 bar***
- 40 to 125 psig / 2,8 to 8,6 bar***

Port B as Inlet

- 7 to 20 psig / 0,48 to 1,4 bar***
- 10 to 30 psig / 0,69 to 2,1 bar***
- 25 to 50 psig / 1,7 to 3,4 bar***
- 40 to 90 psig / 2,8 to 6,2 bar***

1. Product complies with the material requirements of NACE MR0175. Environmental limits may apply.

Regulators Quick Order Guide	
***	Readily Available for Shipment
**	Allow Additional Time for Shipment
*	Special Order, Constructed from Non-Stocked Parts. Consult your local Sales Office for Availability.
Availability of the product being ordered is determined by the component with the longest shipping time for the requested construction.	

Set Pressure Range (Select One) (continued)

Two-Way Switching Valve

Port A as Inlet

- 3 to 15 psig / 0,21 to 1,0 bar (Type 167D only)***
- 5 to 20 psig / 0,34 to 1,4 bar***
- 5 to 35 psig / 0,34 to 2,4 bar***
- 25 to 60 psig / 1,7 to 4,1 bar***
- 40 to 125 psig / 2,8 to 8,6 bar***
- 50 to 150 psig / 3,4 to 10,3 bar (Type 167DS only)***

Diaphragm, O-Rings, and Valve Plug (Select One)

- Nitrile (NBR) (**standard**)***
- Fluorocarbon (FKM)**

Spring Case Vent Location (Select One)

- Position 1 - Aligned with inlet (**standard**)***
- Position 2
- Position 3
- Position 4

NACE MR0175 Construction (Optional)⁽¹⁾

- Yes (not available with gauge)**

NACE MR0103 Construction (Optional)

- Yes (not available with gauge)**

Replacement Parts Kit (Optional)

- Yes, send one replacement parts kit to match this order.

Specification Worksheet	
Application (Please designate units):	
Specific Use	_____
Line Size	_____
Gas Type and Specific Gravity	_____
Gas Temperature	_____
Does the Application Require Overpressure Protection?	
<input type="checkbox"/> Yes	<input type="checkbox"/> No
If yes, which is preferred:	
<input type="checkbox"/> Relief Valve	<input type="checkbox"/> Monitor Regulator
<input type="checkbox"/> Shut-off Device	
Is overpressure protection equipment selection assistance desired? _____	
Pressure (Please designate units):	
Maximum Inlet Pressure (P _{1max})	_____
Minimum Inlet Pressure (P _{1min})	_____
Downstream Pressure Setting(s) (P ₂)	_____
Maximum Flow (Q _{max})	_____
Performance Required: _____	
Accuracy Requirements?	_____
Need for Extremely Fast Response?	_____
Other Requirements: _____	
