

# PRESSURE REGULATORS

Type B/240



## B/240 series

The regulators of the B/240 series due to their operating specifications are mainly used in those system where sudden capacity variations are required, or else, where the cut-off of the gas distribution is controlled by solenoid valve, such as for the feeding of burners.

They can be used with natural gas, manufactured gas, air, propane and other gases, as long as they do not contain a high percentage of benzole.

The B/240 series regulators are springcontrolled single seated, whit counterbalanced valve disc.

They are usually supplied with safety valve and builtin filter and can be also provided with shut-off device for minimum pressure, maximum pressure or minimum and maximum downstream pressure.

The regulators of the series B/240 have been devised keeping in consideration the functionality of maintenance.

In fact is possible to replace the seat or the seals without removing the body from the fine.

Version  
without  
safety  
shut-off device



Version  
with  
safety  
shut-off device

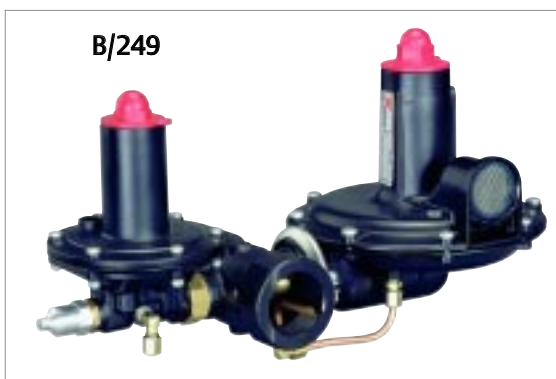

Construction  
features

- Counterbalanced valve
- Built-in relief valve
- Overpressure and underpressure slam shut valve
- Manual reset
- Inlet and outlet in-line

## Operation

The movements of the diaphragm (D) are transmitted to the valve disc (O) by the stem (S) and the lever (L). The downstream pressure through the pulse pipe (I) exerts a force under diaphragm (D) and this force is counteracted by the adjusting spring (M).

The gas pressure on the diaphragm tends to close the valve disc; the antagonist action of the adjustment spring tends to open it. Under normal conditions the balance between these antagonist actions positions the valve disc in such a way as to ensure a constant pressure and therefore the downstream capacity.

Upon any capacity variation tending to cause an increase or decrease of pressure in relation to the pre-set pressure, the moving unit reacts and finds a new balance, so re-establishing the pressure.

Upon request the regulator is also provided with safety valve (Vs) incorporated in the diaphragm (D); the adjustment at the pre-set value is performed by means of spring (M1).

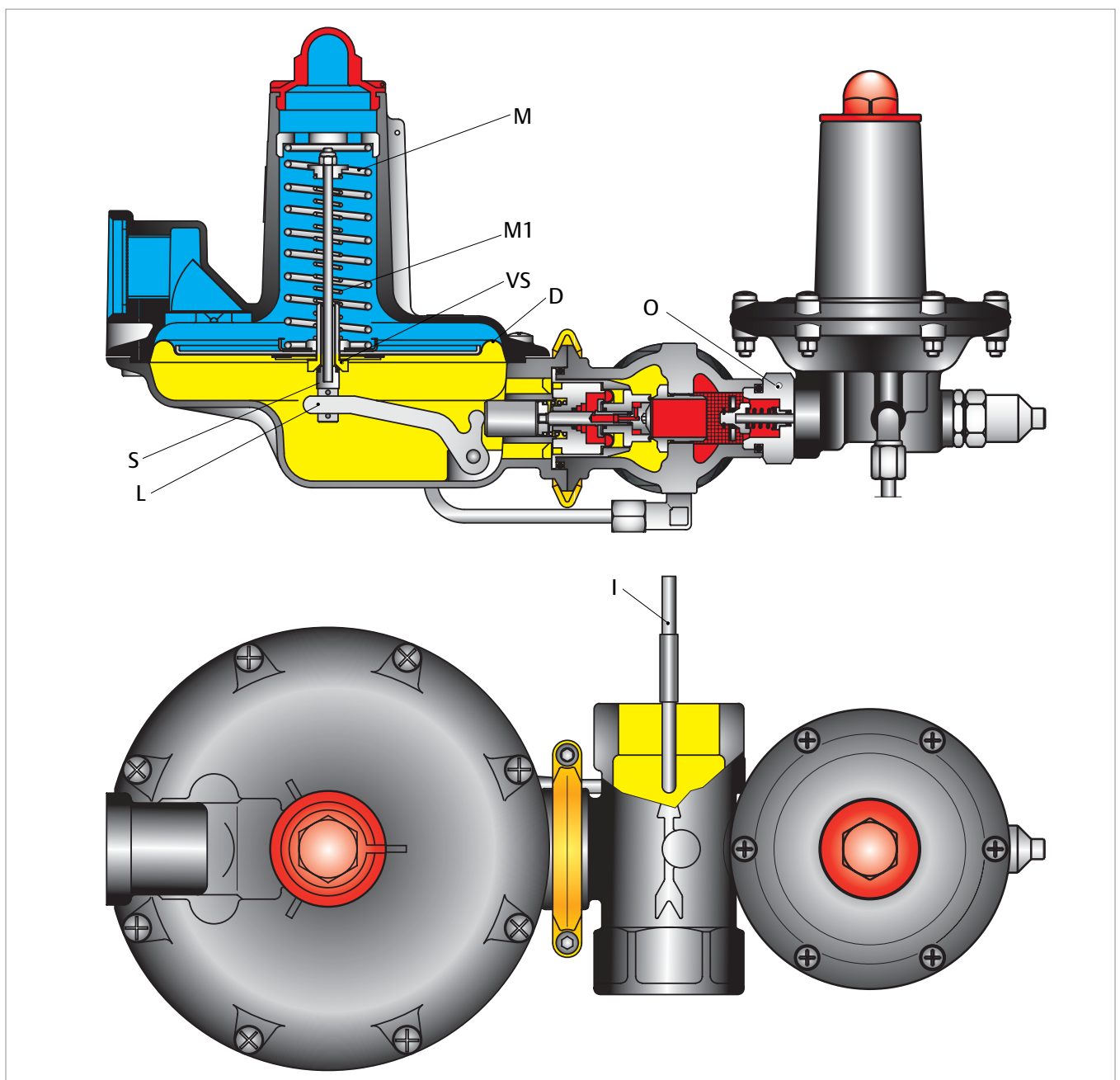

## Shut-off device operation

The B/240 series pressure regulators can be fitted with an OS/66 slam-shut valve. This safety device operates independently of the regulator and, according to customer request, can be made to trigger by any pressure variation, whether above or below set point, or by both.

### How the shut-off device works

Outlet pressure acting upon diaphragm (D) is counteracted by maximum pressure spring (M2), thus overcoming the action of the minimum pressure valve (M3).

Under such conditions, the moving part (E) of the valve is held in balance so that lever (L) is aligned with the projecting part of lever (L1).

In addition, the balls (S) are held in their seat by bush (B) and, in turn, these hold the valve disc (O) open.

Any outlet pressure variation over and above preset value breaks the existing balance.

In fact, in case of an increase in outlet pressure, spring (M2) load is overcome by pressure load; in case of a decrease in outlet pressure, spring (M3) load overcomes pressure load.

In both cases, moving part (E) is activated, causing lever (L) to move with it so that lever (L) is no longer aligned with lever (L1).

In this way, lever (L1) releases balls (S), thereby allowing valve disc (O) to close under the action of spring (M4).

### Resetting

The safety device is fitted with an internal by-pass for easy resetting even in case of high inlet pressure. For resetting, proceed as follows: Remove rear cap (C), screw it to stem (H) and pull outwards. Allow a few moments for inlet pressure to flow downstream.

Next, pull cap fully outwards.

Allow a few moments for outlet pressure to stabilize.

Next, release cap and make sure that device remains in the reset position.

If not, repeat the above steps. Once reset, replace cap in its initial position.

### Setting

The maximum and minimum trip values are independently set by springs (M2) and (M3), respectively.

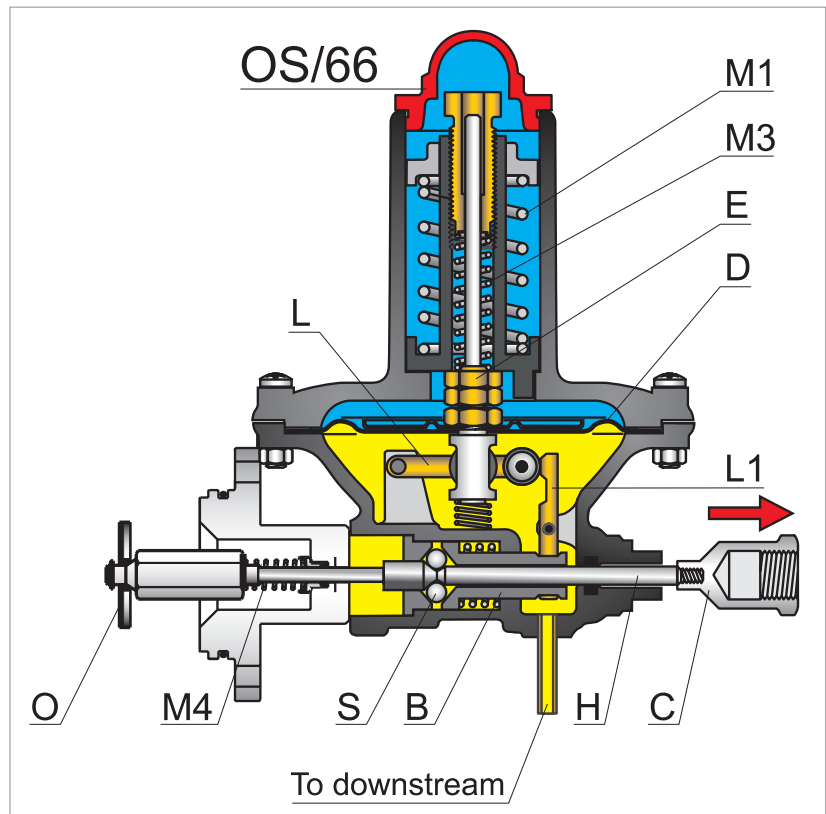

## Features

Technical specifications	Body allowable pressure	PS : 20 bar
	Highest operating pressure	$P_{\max}$ : 300 mbar
	Permissible inlet pressure	$P_{e,\max}$ : 6 bar
	Inlet pressure range	$b_{pe}$ : 0.1 to 6 bar
	Set range	$W_h$ : 10 to 300 mbar
	Accuracy class	AC : up to $\pm 5\%$
	Lock-up pressure class	SG : up to $+10\%$
	Maximum flow rate	$Q_{\max}$ : up to 300 Stm <sup>3</sup> /h
Built-in slam shut valve	Independent pneumatic control	
	Accuracy class	AG : $\pm 5\%$
	Response time	$t_a$ : $\leq 1$ sec.
Orifice	11/16"	
Threaded connections	Inlet and outlet 1½" BSP	
Flanged connections	B/...-FS version DN 40 • PN 16 UNI/DIN	
Temperature	Standard version:	working -10 °C +60 °C
	Low-temperature version:	working -20 °C +60 °C
Configurations	Built-in filter Without relief valve	
Applications	Non-corrosive gases Low temperature	
Materials	Actuator casing	Die-cast aluminium
	Cover	Die-cast aluminium
	Valve casing	Cast-iron
	Valve disc	Brass
	Valve seat	Brass
	Diaphragm	NBR rubber
	Seals	NBR rubber



B/242-FS

## Pilot

**Configurations** The following pilots are used with B/240 series regulator with built-in shut-off device:

- OS/66 Series spring loaded pilot

### Technical features

Model	Servomotor body resistance (bar)	Overpressure set range $W_{ho}$ (bar)		Underpressure set range $W_{hu}$ (bar)	
		min.	max	min.	max
OS/66	6	0.022	0.6	0.007	0.45
OS/66-AP	6	0.2	5	0.1	2.5

### Materials

Body Aluminium  
Cover Steel  
Diaphragm NBR rubber



## Flow rates table $\text{Stm}^3/\text{h}$

Following flow table (referred to Natural Gas) is advised for an optimal use of the B/240 series regulators.

For other gases with different densities, the flow rate must be multiplied by the correction factor:

$$F = \sqrt{\frac{0,6}{d}}$$

Gas	Relative Density d	Factor F
Air	1	0.78
City gas	0.44	1.17
Butane	2.01	0.55
Propane	1.53	0.63
Nitrogen	0.97	0.79
Carbon dioxide	1.52	0.63
Hydrogen	0.07	2.93

	Outlet pressure mbar	Inlet pressure bar															
		0.03	0.05	0.075	0.1	0.15	0.2	0.3	0.4	0.5	0.75	1	1.5	2	3	4	5/6
STANDARD	15	12	15	20	30	40	50	65	80	100	120	120	170	200	250	250	250
	20	—	15	20	30	40	50	65	80	100	120	120	170	200	250	250	250
	30	—	12	20	30	40	50	65	80	100	120	120	170	200	250	250	250
	40	—	—	15	25	40	50	65	80	100	120	120	170	200	250	250	250
	50	—	—	15	20	40	50	65	80	100	120	120	170	200	250	250	250
	75	—	—	—	15	30	45	60	80	100	120	120	170	200	250	250	250
A.P.	100	—	—	—	—	20	40	50	80	100	120	120	170	200	250	280	300
	150	—	—	—	—	—	30	40	70	100	120	120	170	200	250	280	300
	200	—	—	—	—	—	—	30	60	100	120	120	170	200	250	280	300
	300	—	—	—	—	—	—	—	50	80	110	110	170	200	250	280	300





## Overall dimensions mm

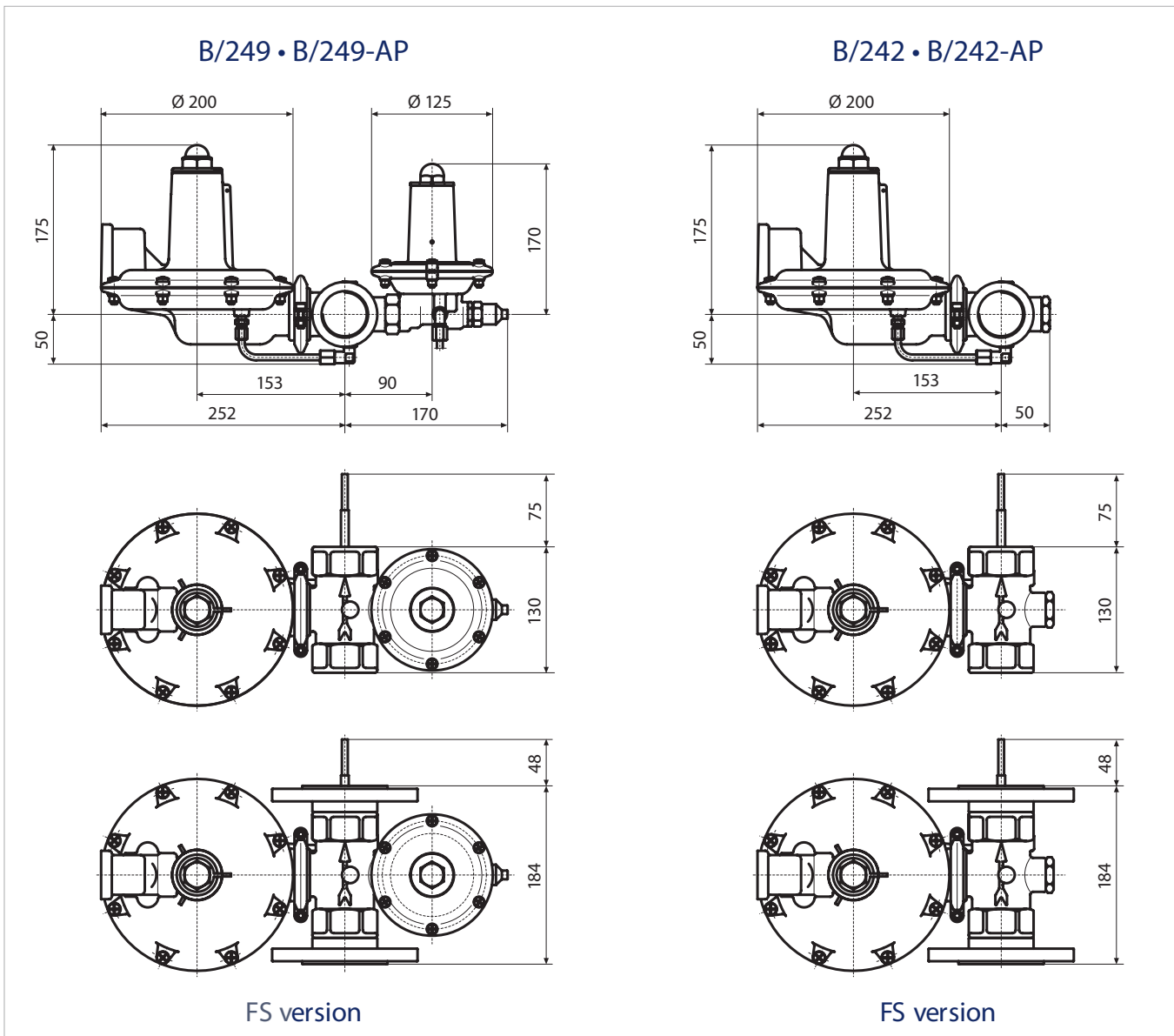

### Natural Gas Technologies

#### Emerson Process Management Regulator Technologies, Inc.

O.M.T.  
Officina Meccanica Tartarini s.r.l.  
Via P. Fabbri, 1  
I - 40013 Castel Maggiore (Bologna), Italy  
Tel. : +39 - 0514190611  
Fax: +39 - 0514190715  
E-mail: info.tartarini@emerson.com

For further information visit [www.emersonprocess.com/regulators](http://www.emersonprocess.com/regulators)

The Emerson logo is a trademark and service mark of Emerson Electric Co. All other marks are the property of their prospective owners. Tartarini is a mark owned by O.M.T. Officina Meccanica Tartarini s.r.l., a business of Emerson Process Management.

*The contents of this publication are presented for informational purposes only, and while every effort has been made to ensure their accuracy, they are not to be construed as warranties or guarantees, express or implied, regarding the products or services described herein or their use or applicability. We reserve the right to modify or improve the designs or specifications of such products at any time without notice.*

O.M.T. Tartarini does not assume responsibility for the selection, use or maintenance of any product. Responsibility for proper selection, use and maintenance of any O.M.T. Tartarini product remains solely with the purchaser.

### Natural Gas Technologies

#### Emerson Process Management Regulator Technologies, Inc.

Francel S.A.  
Z.A. La Croix Saint Mathieu  
28320 Gallardon  
France  
Tel: +33 (0)2 37 33 47 00  
Fax: +33 (0)2 37 31 46 56