

# Rosemount™ 5300 Level Transmitter

## Guided Wave Radar



- Industry leading measurement capability and reliability
- Safety certified to IEC 61508 for SIL2 applications
- Increased plant availability with predictive maintenance and easy troubleshooting
- Reduced instrument count and process penetrations with a multivariable transmitter

# Taking guided wave radar benefits to the next level

## Measurement principle

Low power, nano-second microwave pulses are guided down a probe submerged in the process media. When a microwave pulse reaches a medium with a different dielectric constant, part of the energy is reflected back to the transmitter.

The transmitter uses the residual wave of the first reflection for measuring the interface level. Part of the wave, which was not reflected at the upper product surface, continues until it is reflected at the lower product surface. The speed of this wave depends fully on the dielectric constant of the upper product.

The time difference between the transmitted and the reflected pulse is converted into a distance, and the total level or interface level is then calculated. The reflection intensity depends on the dielectric constant of the product: the higher dielectric constant value, the stronger reflection.

**Figure 1: Measurement Principle**

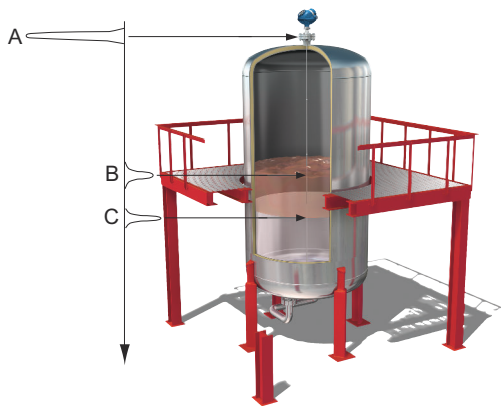

- A. Reference pulse
- B. Level
- C. Interface level

## Guided wave radar technology benefits

- Highly accurate and reliable direct level measurement with no compensation needed for changing process conditions (such as density, conductivity, viscosity, pH, temperature, and pressure)
- No moving parts and no re-calibration result in minimized maintenance
- Handles vapor, dust, turbulence, and foam well
- Suitable for small tanks, difficult tank geometry, internal obstacles, and unaffected by the mechanical design of chambers
- Top down installation minimizes risk for leakages

### Contents

Taking guided wave radar benefits to the next level.....	2
Ordering information.....	4
Specifications.....	23
Product certifications.....	62
Dimensional drawings.....	77

## Special Rosemount 5300 features

### Optimized to suit more applications

- Suitable for most liquid and solids level applications and liquid interface applications
- Handles even the most challenging applications reliably, including process vessels, control, and safety systems
- Easy retrofit in existing chambers or available as complete assembly with high quality Rosemount chambers
- Dynamic Vapor Compensation assures accuracy also in saturated steam
- Large coaxial probe optimized for interface applications where there is a need to measure level and interface level all the way up to flange

### Best performance and uptime

- Unique Direct Switch Technology and Probe End Projection improve capability and reliability particularly in challenging applications
- Single lead probe for long measuring ranges, obstructions and low dielectrics ensures reliability in more applications, such as viscous media
- Signal processing algorithm makes it possible to distinguish between two liquids with a top layer down to 1 in. (2.5 cm).
- Smart Galvanic Interface results in a more stable microwave and EMI performance with minimized effects from outside disturbances

### Robust design and increased safety

- Heavy-duty unique hardware for extreme temperature and pressures with multiple layers of protection
- EchoLogics® and smart software functions provide enhanced ability to keep track of the surface and detect a full vessel situation
- Third party approved for overfill prevention and Safety Integrated System SIL3 suitability
- Electronics and cable connections in separate compartments provides safer handling and improved moisture protection
- Online device verification and reliable detection of high level conditions with the verification reflector

### Easy installation and plant integration

- Easy upgrade by matching existing tank connections and cut-to-fit probes
- Long lengths of rigid probes for robust measurements become cost-effective and practical to ship, store and install with the segmented probe option (code 4S)
- Multivariable device reduces the number of process penetrations
- Seamless system integration with HART®, FOUNDATION™ Fieldbus, Modbus®, or IEC 62591 (*WirelessHART®*) with the Emerson Wireless 775 THUM™ Adapter
- Pre-configured or easy configuration in Rosemount Radar Master with a five-step wizard, auto connect, and online help
- Enhanced DD with step-by-step configuration and echo curve capability in tools such as AMS Device Manager, and handheld communicator
- DTM™ with echo curve capability for use in FDT®/DTM compatible configuration tools such as PACTware™, Yokogawa FieldMate/PRM

### Minimized maintenance reduces cost

- Easy online troubleshooting with user friendly software, utilizing powerful echo curve and logging tools
- Signal Quality Metrics diagnostics detect product build-up on probe to monitor turbulence, boiling, foam, and emulsions
- Predictive maintenance with advanced diagnostics and Plantweb™ alerts
- Modular design for reduced spare parts and easy replacement of the transmitter housing without opening the tank

# Ordering information

## Rosemount 5301 and 5302 Level and/or Interface in Liquids



Rosemount 5301 and 5302 Guided Wave Radar Level Transmitters provide industry leading measurement capabilities and reliability in liquids. Characteristics include:

- Direct Switch Technology and Probe End Projection to handle low reflective media and long measuring ranges
- Wide range of probe styles, materials, and temperatures and pressures for application flexibility
- HART 4-20 mA, FOUNDATION™ Fieldbus, Modbus, or IEC 62591 (WirelessHART®) with the THUM Adapter (see [Emerson Wireless 775 THUM™ Adapter](#) for details)
- Safety-certified to IEC 61508 (option code QT)
- Advanced diagnostics (option code D01 or DA1)
- Transmitter verification and high level supervision (option code HL1, HL2, or HL3)

Specification and selection of product materials, options, or components must be made by the purchaser of the equipment. See [Material selection](#) for more information on material selection.

**Table 1: Rosemount 5301 and 5302 Level and/or Interface in Liquids Ordering Information**

The starred options (★) represent the most common options and should be selected for best delivery. The non-starred offerings are subject to additional delivery lead time.

Model	Product description	
5301	Guided Wave Radar Liquid Level or Interface Transmitter (interface available for fully submerged probe)	★
5302	Guided Wave Radar Liquid Level and Interface Transmitter	★
<b>Signal output</b>		
H	4-20 mA with HART communication (default output from factory is HART 5, add option code HR7 for HART 7) (see <a href="#">4-20 mA HART® (output option code H)</a> for details)	★
F	FOUNDATION Fieldbus (see <a href="#">FOUNDATION™ Fieldbus (output option code F)</a> for details)	★
M	RS-485 with Modbus communication (see <a href="#">Modbus® (output option code M)</a> for details)	★
U	Rosemount 2410 Tank Hub Connectivity	
<b>Housing material</b>		
A	Polyurethane-covered Aluminum	★
S	Stainless Steel, Grade CF8M (ASTM A743)	
<b>Conduit / cable threads</b>		
1	½ - 14 NPT	★
2	M20 x 1.5 adapter	★
4	2 pcs M20 x 1.5 adapter	★
G <sup>(1)(2)</sup>	Metal cable gland (½ - 14 NPT)	★
E <sup>(3)</sup>	M12, 4-pin, male connector (eurofast®)	★
M <sup>(3)</sup>	A size Mini, 4-pin, male connector (minifast®)	★

**Table 1: Rosemount 5301 and 5302 Level and/or Interface in Liquids Ordering Information (continued)**

Operating temperature and pressure (see <a href="#">Process temperature and pressure rating</a> ) <sup>(4)</sup>		Probe type	
S	Standard: - 15 to 580 psig @ 302 °F (-1 to 40 bar @ 150 °C)	1A, 2A, 3A, 3B, 3C, 4A, 4B, 4S, 5A, and 5B	★
H <sup>(5)</sup>	High Temperature / High Pressure: 5000 psi @ 100 °F and 2940 psi @ 752 °F (345 bar @ 38 °C and 203 bar @ 400 °C)	3A, 3B, 3V, 4A, 4B, 4S, 4U, 5A, and 5B	★
P <sup>(5)</sup>	High Pressure: 5000 psi @ 100 °F and 3320 psi @ 482 °F (345 bar @ 38 °C and 228.9 bar @ 250 °C)	3A, 3B, 3C, 4A, 4B, 4S, 5A, and 5B	★
C <sup>(5)</sup>	Cryogenic Temperature: 5000 psi @ -321 °F and 3524 psi @ 392 °F (345 bar @ -196 °C and 243 bar @ 200 °C)	3A, 3B, 3C, 4A, 4B, 4S, 5A, 5B (Only SST)	
Material of construction <sup>(6)</sup> : Process connection / probe		Probe type	Valid operation temperature and pressure
1	316/316L/EN 1.4404	All	S, H, P, C
2	Alloy C-276 (UNS N10276). With plate design if flanged version. Up to class 600/PN 63 for HTHP/HP probes.	3A, 3B, 4A, 4B, 5A, 5B	S, H, P
3	Alloy 400 (UNS N04400). With plate design if flanged version.	3A, 3B, 4A, 4B, 5A, 5B	S
7	PTFE covered probe and flange. With plate design.	4A and 5A	S
8	PTFE covered probe	4A and 5A	S
H	Alloy C-276 (UNS N10276) process connection, flange, and probe	3A, 3B, 4A, 4B, 5A, 5B	S, H, P
D	Duplex 2205 (EN 1.4462/UNS S31803) process connection, flange, and probe	4B, 5A, 5B	S, H, P
Sealing, O-ring material (consult the factory for other O-ring materials)			
N <sup>(7)</sup>	None		★
V	Viton® Fluoroelastomer		★
E	Ethylene Propylene (EPDM)		★
K	Kalrez® 6375 Perfluoroelastomer		★
B	Nitrile Butadiene (NBR)		★
L <sup>(8)(9)</sup>	Low temperature Viton Fluoroelastomer		
F <sup>(8)(9)</sup>	Fluorsilicone (FVMQ)		
Probe type		Process connections	Probe lengths
3B	Coaxial, perforated. For level and interface measurement.	Flange / 1-in. <sup>(10)</sup> , 1½-in., 2-in. <sup>(10)</sup> Thread	Min: 1 ft. 4 in. (0.4 m) Max: 19 ft. 8 in. (6 m)

**Table 1: Rosemount 5301 and 5302 Level and/or Interface in Liquids Ordering Information (continued)**

3C <sup>(11)</sup>	Large coaxial, perforated. For level and interface measurement.	Flange / 1½-in., 2-in. <sup>(10)</sup> Thread	Min: 1 ft. (0.3 m) Max: 19 ft. 8 in. (6 m)	★
3V <sup>(12)</sup> <sup>(13)</sup>	Integrated Still Pipe Vapor Probe. For 3-in. chambers and above. Refer to "Options" to specify reference reflector length.	Flange	Min: 2 ft. 11 in. (0.9 m) for the short reflector (R1 option) Min: 3 ft. 7 in. (1.1 m) for the long reflector (R2 option) Max: 13 ft. 1 in. (4 m)	★
4A	Rigid Single Lead (8 mm)	Flange / 1-in. <sup>(10)</sup> , 1½-in., 2-in. <sup>(10)</sup> Thread / Tri-Clamp <sup>®</sup>	Min: 1 ft. 4 in. (0.4 m) Max: 9 ft. 10 in. (3 m)	★
4B	Rigid Single Lead (13mm)	Flange / 1-in., 1½-in., 2-in. Thread / Tri-Clamp	Min: 1 ft. 4 in. (0.4 m) Max: 19 ft. 8 in. (6 m)	★
4U <sup>(12)</sup> <sup>(13)</sup>	Single Rigid Vapor Probe (equip with a 1½-in. centering disc). For 2-in. chambers. Refer to "Options" to specify reference reflector length.	Flange / 1½-in. Thread	Min: 2 ft. 11 in. (0.9 m) for the short reflector (R1 option) Min: 3 ft. 7 in. (1.1 m) for the long reflector (R2 option) Max: 9 ft. 10 in. (3 m)	★
5A <sup>(14)</sup>	Flexible Single Lead with weight	Flange / 1-in. <sup>(10)</sup> , 1½-in., 2-in. <sup>(10)</sup> Thread / Tri-Clamp	Min: 3 ft. 4 in. (1 m) Max: 164 ft. (50 m) <sup>(15)</sup>	★
5B <sup>(16)</sup>	Flexible Single Lead with chuck	Flange / 1-in. <sup>(10)</sup> , 1½-in., 2-in. <sup>(10)</sup> Thread / Tri-Clamp	Min: 3 ft. 4 in. (1 m) Max: 164 ft. (50 m) <sup>(15)</sup>	★
1A <sup>(10)</sup>	Rigid Twin Lead	Flange / 1½-in., 2-in. <sup>(10)</sup> Thread	Min: 1 ft. 4 in. (0.4 m) Max: 9 ft. 10 in. (3 m)	
2A <sup>(10)</sup>	Flexible Twin Lead with weight	Flange / 1½-in., 2-in. <sup>(10)</sup> Thread	Min: 3 ft. 4 in. (1 m) Max: 164 ft. (50 m)	
3A <sup>(17)</sup>	Coaxial (for level measurement)	Flange / 1-in. <sup>(10)</sup> , 1½-in., 2-in. <sup>(10)</sup> Thread	Min: 1 ft. 4 in. (0.4 m) Max: 19 ft. 8 in. (6 m)	
4S	Segmented Rigid Single Lead (13mm)	Flange / 1-in., 1½-in., 2-in. Thread / Tri-Clamp	Min: 1 ft. 4 in. (0.4 m) Max: 32 ft. 9 in. (10 m)	
<b>Probe length units</b>				
E	English (feet, in.)			★
M	Metric (meters, centimeters)			★
<b>Total probe length (feet/m) <sup>(18)</sup></b>				
XXX	0-164 ft. or 0-50 m			★
<b>Total probe length (in./cm)<sup>(18)</sup></b>				
XX	0-11 in. or 0-99 cm			★

**Table 1: Rosemount 5301 and 5302 Level and/or Interface in Liquids Ordering Information (continued)**

<b>Process connection - size / type (consult the factory for other process connections)</b>			
ASME flanges		Material of construction	Operating temperature and pressure
AA	2-in. Class 150, RF (Raised Face Type)	1, 2, 3, 7, 8, H, D	S, H, P, C ★
AB	2-in. Class 300, RF (Raised Face Type)	1, 2, 3, 7, 8, H, D	S, H, P, C ★
AC	2-in. Class 600, RF (Raised Face Type)	1, 2, H, D	H, P, C ★
AD	2-in. Class 900, RF (Raised Face Type)	1, H, D	H, P, C ★
BA	3-in. Class 150, RF (Raised Face Type)	1, 2, 3, 7, 8, H, D	S, H, P, C ★
BB	3-in. Class 300, RF (Raised Face Type)	1, 2, 3, 7, 8, H, D	S, H, P, C ★
BC	3-in. Class 600, RF (Raised Face Type)	1, 2, H, D	H, P, C ★
BD	3-in. Class 900, RF (Raised Face Type)	1, H, D	H, P, C ★
CA	4-in. Class 150, RF (Raised Face Type)	1, 2, 3, 7, 8, H, D	S, H, P, C ★
CB	4-in. Class 300, RF (Raised Face Type)	1, 2, 3, 7, 8, H, D	S, H, P, C ★
CC	4-in. Class 600, RF (Raised Face Type)	1, 2, H, D	H, P, C ★
CD	4-in. Class 900, RF (Raised Face Type)	1, H, D	H, P, C ★
AE	2-in. Class 1500, RF (Raised Face Type)	1, H, D	H, P, C
AF	2-in. Class 2500, RF (Raised Face Type)	1	H, P, C
AI	2-in. Class 600, RTJ (Ring Type Joint)	1, H, D	H, P, C
AJ	2-in. Class 900, RTJ (Ring Type Joint)	1, H, D	H, P, C
AK	2-in. Class 1500, RTJ (Ring Type Joint)	1, H, D	H, P, C
BE	3-in. Class 1500, RF (Raised Face Type)	1, H, D	H, P, C
BF	3-in. Class 2500, RF (Raised Face Type)	1	H, P, C
BI	3-in. Class 600, RTJ (Ring Type Joint)	1, H, D	H, P, C
BJ	3-in. Class 900, RTJ (Ring Type Joint)	1, H, D	H, P, C
BK	3-in. Class 1500, RTJ (Ring Type Joint)	1, H, D	H, P, C
CE	4-in. Class 1500, RF (Raised Face Type)	1, H, D	H, P, C
CF	4-in. Class 2500, RF (Raised Face Type)	1	H, P, C
CI	4-in. Class 600, RTJ (Ring Type Joint)	1, H, D	H, P, C
CJ	4-in. Class 900, RTJ (Ring Type Joint)	1, H, D	H, P, C
CK	4-in. Class 1500, RTJ (Ring Type Joint)	1, H, D	H, P, C
DA	6-in. Class 150, RF (Raised Face Type)	1, 2, 3, 7, 8, H	S, H, P, C
EN 1092-1 flanges		Material of construction	Operating temperature and pressure
HB	DN50, PN40, Type A flat face	1, 2, 3, 7, 8	S, H, P, C ★
HC	DN50, PN63, Type A flat face	1, 2, 3	H, P, C ★
HD	DN50, PN100, Type A flat face	1	H, P, C ★
IA	DN80, PN16, Type A flat face	1, 2, 3, 7, 8	S, H, P, C ★

**Table 1: Rosemount 5301 and 5302 Level and/or Interface in Liquids Ordering Information (continued)**

IB	DN80, PN40, Type A flat face	1, 2, 3, 7, 8	S, H, P, C	★
IC	DN80, PN63, Type A flat face	1, 2, 3	H, P, C	★
ID	DN80, PN100, Type A flat face	1	H, P, C	★
JA	DN100, PN16, Type A flat face	1, 2, 3, 7, 8	S, H, P, C	★
JB	DN100, PN40, Type A flat face	1, 2, 3, 7, 8	S, H, P, C	★
JC	DN100, PN63, Type A flat face	1, 2, 3	H, P, C	★
JD	DN100, PN100, Type A flat face	1	H, P, C	★
HE	DN50, PN160, Type B2 raised face	1	H, P, C	
HF	DN50, PN250, Type B2 raised face	1	H, P, C	
HI	DN50, PN40, Type E spigot face	1, 8	S, H, P, C	
HP	DN50, PN16, Type C tongue face	1, 8	S, H, P, C	
HQ	DN50, PN40, Type C tongue face	1, 8	S, H, P, C	
IE	DN80, PN160, Type B2 raised face	1	H, P, C	
IF	DN80, PN250, Type B2 raised face	1	H, P, C	
IH	DN80, PN16, Type E spigot face	1, 8	S, H, P, C	
II	DN80, PN40, Type E spigot face	1, 8	S, H, P, C	
IP	DN80, PN16, Type C tongue face	1, 8	S, H, P, C	
IQ	DN80, PN40, Type C tongue face	1, 8	S, H, P, C	
JE	DN100, PN160, Type B2 raised face	1	H, P, C	
JF	DN100, PN250, Type B2 raised face	1	H, P, C	
JH	DN100, PN16, Type E spigot face	1, 8	S, H, P, C	
JI	DN100, PN40, Type E spigot face	1, 8	S, H, P, C	
JP	DN100, PN16, Type C tongue face	1, 8	S, H, P, C	
JQ	DN100, PN40, Type C tongue face	1, 8	S, H, P, C	
KA	DN150, PN16, Type A flat face	1, 2, 3, 7, 8	S, H, P, C	
JIS flanges		Material of construction	Operating temperature and pressure	
UA	50A, 10K, RF (Raised Face Type)	1, 2, 3, 7, 8	S, H, P, C	★
VA	80A, 10K, RF (Raised Face Type)	1, 2, 3, 7, 8	S, H, P, C	★
XA	100A, 10K, RF (Raised Face Type)	1, 2, 3, 7, 8	S, H, P, C	★
UB	50A, 20K, RF (Raised Face Type)	1, 2, 3, 7, 8	S, H, P, C	
VB	80A, 20K, RF (Raised Face Type)	1, 2, 3, 7, 8	S, H, P, C	
XB	100A, 20K, RF (Raised Face Type)	1, 2, 3, 7, 8	S, H, P, C	
YA	150A, 10K, RF (Raised Face Type)	1, 2, 3, 7, 8	S, H, P, C	
YB	150A, 20K, RF (Raised Face Type)	1, 2, 3, 7, 8	S, H, P, C	
ZA	200A, 10K, RF (Raised Face Type)	1, 2, 3, 7, 8	S, H, P, C	



**Table 1: Rosemount 5301 and 5302 Level and/or Interface in Liquids Ordering Information (continued)**

ZB	200A, 20K, RF (Raised Face Type)	1, 2, 3, 7, 8	S, H, P, C	
Threaded connections		Material of construction	Probe type	
RA	1½-in. NPT thread	1, 2, 3, 8, H, D	1A, 2A, 3A, 3B, 3C, 4A, 4B, 4S, 4U, 5A, 5B	★
RC	2-in. NPT thread	1, 8	1A, 2A, 3A, 3B, 3C, 4A, 4B, 4S, 5A, 5B, standard temperature and pressure	★
RB	1-in. NPT thread	1, 8	3A, 3B, 4A, 4B, 4S, 5A, 5B, standard temperature and pressure	
SA	1½-in. BSP (G 1½-in.) thread	1, 2, 3, 8, H, D	1A, 2A, 3A, 3B, 3C, 4A, 4B, 4S, 4U, 5A, 5B	
SB	1-in. BSP (G 1-in.) thread	1, 8	3A, 3B, 4A, 4B, 4S, 5A, 5B, standard temperature and pressure	
Tri-Clamp fittings		Material of construction	Probe type	
FT	1½-in. Tri-Clamp	1, 7, 8	4A, 5A, 5B standard temperature and pressure	
AT	2-in. Tri-Clamp	1, 7, 8	4A, 4B, 5A, 5B, 4S standard temperature and pressure	
BT	3-in. Tri-Clamp	1, 7, 8	4A, 4B, 5A, 5B, 4S standard temperature and pressure	
CT	4-in. Tri-Clamp	1, 7, 8	4A, 4B, 5A, 5B, 4S standard temperature and pressure	
Proprietary flanges				
TF	Fisher - proprietary 316/316L (for 249B, 259B chambers) Torque Tube Flange	1, 7, 8	S, H, P, C	★
TT	Fisher - proprietary 316/316L (for 249C chambers) Torque Tube Flange	1, 7, 8	S, H, P, C	★
TM	Masoneilan - proprietary 316/316L Torque Tube Flange	1, 7, 8	S, H, P, C	★
<b>Hazardous locations certifications (see <a href="#">Product certifications</a>)</b>				
NA	No Hazardous Locations Certifications			★
E1 <sup>(19)</sup>	ATEX Flameproof			★
E3 <sup>(19)</sup>	China Flameproof			★
E5 <sup>(19)</sup>	USA Explosion-proof			★
E6 <sup>(19)</sup>	Canadian Explosion-proof			★
E7 <sup>(19)</sup>	IECEX Flameproof			★
I1	ATEX Intrinsic Safety			★
IA <sup>(20)</sup>	ATEX FISCO Intrinsic Safety			★

**Table 1: Rosemount 5301 and 5302 Level and/or Interface in Liquids Ordering Information (continued)**

I3	China Intrinsic Safety	★
IC <sup>(20)</sup>	China FISCO Intrinsic Safety	★
I5	USA Intrinsic Safety and Non-Incendive	★
IE <sup>(20)</sup>	USA FISCO Intrinsic Safety	★
I6	Canadian Intrinsic Safety	★
IF <sup>(20)</sup>	Canadian FISCO Intrinsic Safety	★
I7	IECEX Intrinsic Safety	★
IG <sup>(20)</sup>	IECEX FISCO Intrinsic Safety	★
E2 <sup>(19)</sup>	INMETRO Flameproof	
EM <sup>(19)</sup>	Technical Regulations Customs Union (EAC) Flameproof	
I2	INMETRO Intrinsic Safety	
IB <sup>(20)</sup>	INMETRO FISCO Intrinsic Safety	
IM	Technical Regulations Customs Union (EAC) Intrinsic Safety	
IN <sup>(20)</sup>	Technical Regulations Customs Union (EAC) FISCO Intrinsic Safety	
E4 <sup>(19)(21)</sup>	Japan Flameproof	
EP <sup>(19)</sup>	Republic of Korea Flameproof	
KA <sup>(19)</sup>	ATEX, USA, Canadian Flameproof/Explosion-proof	
KB <sup>(19)</sup>	ATEX, USA, IECEX Flameproof/Explosion-proof	
KC <sup>(19)</sup>	ATEX, Canadian, IECEX Flameproof/Explosion-proof	
KD <sup>(19)</sup>	USA, Canadian, IECEX Flameproof/Explosion-proof	
KE	ATEX, USA, Canadian Intrinsic Safety	
KF	ATEX, USA, IECEX Intrinsic Safety	
KG	ATEX, Canadian, IECEX Intrinsic Safety	
KH	USA, Canadian, IECEX Intrinsic Safety	
KI <sup>(20)</sup>	FISCO - ATEX, USA, Canadian Intrinsic Safety	
KJ <sup>(20)</sup>	FISCO - ATEX, USA, IECEX Intrinsic Safety	
KK <sup>(20)</sup>	FISCO - ATEX, Canadian, IECEX Intrinsic Safety	
KL <sup>(20)</sup>	FISCO - USA, Canadian, IECEX Intrinsic Safety	
N1	ATEX Type n	
N7	IECEX Type n	
<b>Options (include with selected model number)</b>		
<b>Display</b>		
M1	Integral digital display	★
<b>Communication</b>		
HR7	4–20 mA with digital signal based on HART 7 protocol	★

**Table 1: Rosemount 5301 and 5302 Level and/or Interface in Liquids Ordering Information (continued)**

<b>Hydrostatic testing</b>		
P1 <sup>(22)</sup>	Hydrostatic testing	★
<b>Factory configuration</b>		
C1	Factory configuration (Configuration Data Sheet required with order, available at <a href="http://Emerson.com/Rosemount">Emerson.com/Rosemount</a> )	★
<b>Alarm limit configuration</b>		
C4	Namur alarm and saturation levels, high alarm	★
C5	Namur alarm and saturation levels, low alarm	★
C8 <sup>(23)</sup>	Low alarm (standard Rosemount alarm and saturation levels)	★
<b>Welding documentation <sup>(24)</sup></b>		
Q66	Welding Procedure Qualification Record Documentation	
Q67	Welder Performance Qualification Record	
Q68	Welding Procedure Specification	
<b>Special certifications</b>		
Q4	Calibration Data Certification	★
Q8 <sup>(25)</sup>	Material Traceability Certification consistent with ISO10474-3.1:2013 / EN10204-3.1:2004	★
QG	GOST Primary Verification Certificate (only for end-destination country Russia)	
<b>Safety certifications</b>		
QS	Prior-use certificate of FMEDA Data. Only available with HART 4-20 mA output (output code H).	★
QT	Safety-certified to IEC 61508 with certificate of FMEDA data. Only available with HART 4-20 mA output (output code H).	★
<b>Country certification</b>		
J1	Canadian Registration Number (CRN)	★
J2 <sup>(26)</sup>	ASME B31.1	★
J7 <sup>(27)</sup>	Indian Boiler Regulation (For witnessed Form III-C from factory, order certificate Q47 on separate line item)	
J8 <sup>(28)(29)</sup>	EN Boiler (European Boiler Approval in accordance with EN 12952-11 and EN 12953-9)	★
<b>Dye penetration test certificate</b>		
Q73	Certificate of Liquid Penetrant Inspection	★
<b>Positive material identification certificate</b>		
Q76	Positive Material Identification Certificate of Conformance	★
<b>Materials certification</b>		
N2 <sup>(30)</sup>	NACE® material recommendation per NACE MR0175/ISO 15156 and NACE MR0103/ISO 17945	★
<b>Marine / shipboard approvals<sup>(31)</sup></b>		
SBS	American Bureau of Shipping Type Approval	
SDN	Det Norske Veritas Germanischer Lloyd (DNV GL) Type Approval	
SLL	Lloyd's Register Type Approval	
SKR	Korean Register Type Approval	

**Table 1: Rosemount 5301 and 5302 Level and/or Interface in Liquids Ordering Information (continued)**

SBV	Bureau Veritas Type Approval	
<b>Installation options</b>		
LS <sup>(32)</sup>	Long stud 9.8 in (250 mm) for flexible single lead probe to prevent contact with wall/nozzle. Standard stud length is 3.9 in (100 mm) for probes 5A and 5B.	★
BR	316L Mounting Bracket for 1½-in. NPT Process Connection (RA) (see <a href="#">Figure 47</a> )	
<b>Weight and anchoring options for flexible single probes (probe type 5A)</b>		
W3	Heavy weight (recommended choice for most applications) Weight=2.43 lb (1.10 kg), Length=5.5 in. (140 mm), Diameter=1.5 in. (37.5 mm)	★
W2	Short weight (when measuring close to the probe end) Weight=0.88 lb (0.40 kg), Length=2 in. (50 mm), Diameter=1.5 in. (37.5 mm)	
<b>Weight assembly options for flexible single probes</b>		
WU	Weight or chuck not mounted on the probe	★
<b>Transient protection</b>		
T1	Transient Protection Terminal Block. Selectable with HART 4-20 mA output (output code H). Already included in all FOUNDATION Fieldbus variations.	★
<b>Diagnostic functionality</b>		
D01	FOUNDATION Fieldbus Diagnostics Suite (includes Signal Quality Metrics diagnostics)	★
DA1	HART Diagnostics Suite (includes Signal Quality Metrics diagnostics)	★
<b>Cold temperature</b>		
BR5 <sup>(33)(34)(35)(36)</sup>	-67 °F (-55 °C) cold temperature (pending, consult factory)	
<b>Verification reflectors (high level supervision)</b>		
HL1 <sup>(37)</sup>	Verification reflector for 3- to 6-in. pipe/chamber (High Level Supervision). See <a href="#">Verification reflector (option code HL1, HL2, or HL3)</a> for details.	
HL2 <sup>(37)</sup>	Verification reflector for 8-in. pipe/chamber (High Level Supervision). See <a href="#">Verification reflector (option code HL1, HL2, or HL3)</a> for details.	
HL3 <sup>(37)</sup>	Verification reflector for tanks and 10-in. or wider pipe/chamber (High Level Supervision). See <a href="#">Verification reflector (option code HL1, HL2, or HL3)</a> for details.	
<b>Overfill prevention</b>		
U1 <sup>(38)</sup>	WHG Overfill Approval	★
<b>Extended product warranty</b>		
WR3 <sup>(39)</sup>	3-year limited warranty	★
WR5 <sup>(39)</sup>	5-year limited warranty	★
<b>Centering discs (see <a href="#">Table 33</a> for size recommendation)</b>		<b>Outer diameter</b>
S2 <sup>(40)</sup>	2-in. Centering disc	1.8 in. (45 mm)
S3 <sup>(40)</sup>	3-in. Centering disc	2.7 in. (68 mm)
S4 <sup>(40)</sup>	4-in. Centering disc	3.6 in. (92 mm)
P2 <sup>(41)</sup>	2-in. Centering disc PTFE	1.8 in. (45 mm)
P3 <sup>(41)</sup>	3-in. Centering disc PTFE	2.7 in. (68 mm)

**Table 1: Rosemount 5301 and 5302 Level and/or Interface in Liquids Ordering Information (continued)**

P4 <sup>(41)</sup>	4-in. Centering disc PTFE	3.6 in. (92 mm)	★
S6 <sup>(40)</sup>	6-in. Centering disc	5.55 in. (141 mm)	
S8 <sup>(40)</sup>	8-in. Centering disc	7.40 in. (188 mm)	
P6 <sup>(41)</sup>	6-in. Centering disc PTFE	5.55 in. (141 mm)	
P8 <sup>(41)</sup>	8-in. Centering disc PTFE	7.40 in. (188 mm)	
<b>Remote housing mounting<sup>(42)</sup> (see Figure 48)</b>			
B1	1 m / 3.2 ft. Remote Housing Mounting Cable and 316L Bracket		
B2	2 m / 6.5 ft. Remote Housing Mounting Cable and 316L Bracket		
B3	3 m / 9.8 ft. Remote Housing Mounting Cable and 316L Bracket		
<b>Reference reflectors for dynamic vapor compensation probes (required for probe type 3V and 4U) (See Select reference reflector for reflector length guidelines)</b>			
R1	Short reflector. Length=14 in. (350 mm)		
R2	Long reflector. Length=20 in. (500 mm)		
<b>Consolidate to chamber (see Rosemount chamber)</b>			
XC <sup>(43)</sup>	Consolidate to Chamber		
<b>Engineered solutions (see Engineered solutions)</b>			
Rxxxx	Engineered Solutions beyond standard model codes. (Consult factory for details)		
<b>Example model string: 5301-H-A-1-S-1-V-1A-M-002-05-AA-I1-M1C1 E-002-05, means 2 ft. and 5 in. probe length. M-002-05, means 2.05 m.</b>			

- (1) Not available with explosion-proof or flameproof approvals.
- (2) Minimum temperature is -20 °C (-4 °F).
- (3) Not available with explosion-proof, flameproof, or type n approvals.
- (4) Process seal rating. Final rating depends on flange and O-ring selection. See "Temperature and pressure limits" on [Process temperature and pressure rating](#), [Flange rating](#), [Tri-Clamp® rating](#), and [Plate design](#).
- (5) Requires option None for sealing (no O-ring).
- (6) For other materials, consult the factory.
- (7) Requires Operating Temperature and Pressure code H, P, or C.
- (8) Only available for Probe Type code 3C.
- (9) Consult factory.
- (10) Only available with Operating Temperature and Pressure code S.
- (11) Requires firmware version 2.L3 or later.
- (12) Only available with Operating Temperature and Pressure code H.
- (13) Not available with Remote housing code B1 or B2.
- (14) 0.79 lb (0.36 kg) standard weight for flexible single lead probe. L=5.5 in. (140 mm). For PTFE covered probes: 2.2 lb (1 kg) standard weight for flexible single lead probe. L=17.1 in. (434 mm).
- (15) Maximum probe length for Duplex 2205 probes is 105 ft (32 m).
- (16) Extra length for fastening is added in factory.
- (17) Requires model 5301.
- (18) Probe weight included if applicable. Give the total probe length in feet and inches or meters and centimeters, depending on selected probe length unit. If tank height is unknown, please round up to an even length when ordering. Probes can be cut to exact length in field. Maximum allowable length is determined by process conditions. See [Total probe length](#) for more probe length guidance.
- (19) Probes are intrinsically safe.
- (20) Requires FOUNDATION Fieldbus signal output (U<sub>i</sub> parameter listed in [Product certifications](#)).
- (21) G ½ in. SST cable gland is included in delivery.
- (22) Available for tank connection with flange.
- (23) The standard alarm setting is high.
- (24) Weldings in accordance with EN/ISO standards.

- (25) Certificate includes all pressure retaining wetted parts.
- (26) Design and manufacturing according to ASME B31.1. No code stamp available. Welding in accordance with ASME IX.
- (27) Only available with Material of construction code 1, Operating temperature and pressure code S, H, or P, Probe type 3A, 3B, 3V, 4U, 4A, 4B, 4S, 5A, or 5B, together with ASME flanges size 2-in, 3-in, or 4-in.
- (28) Only available with Signal output code H and Probe type code 3V or 4U.
- (29) Suitable for use as a level sensor part of a limiting device, in accordance with EN 12952-11 and EN 12953-9.
- (30) For Probe Type 3A, 3B, 3C, 4A, 4B, 4S, and 4U, and PTFE-coated 5A.
- (31) Transmitters with aluminum housing are not approved for open deck installations.
- (32) Not available with PTFE covered probes.
- (33) Consider any temperature limitations dependent on Material of construction, Hazardous locations certifications, and/or O-ring selection.
- (34) Not available with option code QS or U1.
- (35) Option code BR5 together with Remote housing options (B1, B2, B3) or Verification reflector options (HL1, HL2, HL3) is pending, consult factory.
- (36) For ambient temperatures between -67 °F (-55 °C) and -40 °F (-40 °C), the ambient temperature effect is  $\pm 0.012 \text{ in. (0.3 mm) } / ^\circ\text{K}$  or  $\pm 45 \text{ ppm} / ^\circ\text{K}$  of measured value, whichever is greatest. Other performance specifications apply to ambient temperatures between -40 °F (-40 °C) and 185 °F (85 °C).
- (37) Only available with HART 4-20 mA output (code H), standard operating temperature and pressure (code S), material of construction (code 1), and flexible single lead probes (probe type 5A or 5B).
- (38) Cannot be combined with E2 (INMETRO Flameproof) or I2 (INMETRO Intrinsic Safety).
- (39) Rosemount extended warranties have a limited warranty of three or five years from date of shipment.
- (40) Available for SST, Alloy C-276, Alloy 400, and Duplex 2205 probes, type 2A, 4A, 4B, 4S, and 5A. Same disc material as probe material. For more information, see [Centering disc for pipe installations](#).
- (41) Available for probe types 2A, 4A, 4B, 4S, and 5A. Not available with Operating Temperature and Pressure code H or Material of Construction codes 7 and 8.
- (42) Not available with Marine / shipboard approvals.
- (43) Selecting the XC option code on the Rosemount 5300 Guided Wave Radar and a Rosemount chamber will result in matching, consolidating, configuring, and shipping of the two products in one crate. Note that the flange bolts are only hand-tightened. Long rigid single lead probes (>8 ft./2.5 m) are ship separately in order to reduce transportation risk damage.

## Rosemount 5303 Level for Solids

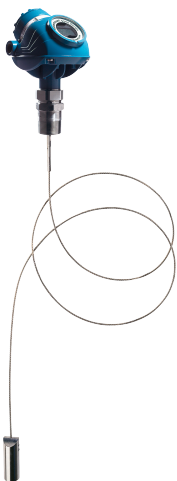

Rosemount 5303 Guided Wave Radar Level Transmitter provides industry leading measurement capabilities and reliability on solids. Characteristics include:

- Direct Switch Technology and Probe End Projection to handle low reflective media and long measuring ranges
- Measurement independent of dust, moisture and material fluctuations
- HART 4-20 mA, FOUNDATION™ Fieldbus, Modbus, or IEC 62591 (WirelessHART®) with the THUM Adapter (see [Emerson Wireless 775 THUM™ Adapter](#) for details)
- Probes for high physical weight loads (probe type 6A and 6B)
- Long stud available to prevent contact with nozzle (LS option)

Specification and selection of product materials, options, or components must be made by the purchaser of the equipment. See [Material selection](#) for more information on material selection.

**Table 2: Rosemount 5303 Level for Solids Ordering Information**

The starred options (★) represent the most common options and should be selected for best delivery. The non-starred offerings are subject to additional delivery lead time.

Model	Product description	
5303	Guided Wave Solids Level Transmitter	★

**Table 2: Rosemount 5303 Level for Solids Ordering Information (continued)**

<b>Signal output</b>			
H	4-20 mA with HART communication (default output from factory is HART 5, add option code HR7 for HART 7) (see <a href="#">4-20 mA HART® (output option code H)</a> for details)		★
F	FOUNDATION Fieldbus (see <a href="#">FOUNDATION™ Fieldbus (output option code F)</a> for details)		★
M	RS-485 with Modbus communication (see <a href="#">Modbus® (output option code M)</a> for details)		★
<b>Housing material</b>			
A	Polyurethane-covered Aluminum		★
S	Stainless Steel, Grade CF8M (ASTM A743)		
<b>Conduit / cable threads</b>			
1	½ - 14 NPT		★
2	M20 x 1.5 adapter		★
4	2 pcs M20 x 1.5 adapter		★
G <sup>(1)(2)</sup>	Metal cable gland (½ - 14 NPT)		★
E <sup>(3)</sup>	M12, 4-pin, Male connector (eurofast)		★
M <sup>(3)</sup>	A size Mini, 4-pin, Male connector (minifast)		★
<b>Operating temperature and pressure (see <a href="#">Process temperature and pressure rating</a>)<sup>(4)</sup></b>			<b>Probe type</b>
S	Standard: - 15 to 580 psig @ 302 °F (-1 to 40 bar @ 150 °C)		All
<b>Material of construction<sup>(5)</sup>: process connection / probe</b>			<b>Probe type</b>
1	316/316L/ EN 1.4404		All
<b>Sealing, O-ring material (consult factory for other O-ring materials)</b>			
V	Viton® Fluoroelastomer		★
E	Ethylene Propylene (EPDM)		★
K	Kalrez® 6375 Perfluoroelastomer		★
B	Nitrile Butadiene (NBR)		★
<b>Probe type</b>	<b>Process connection</b>	<b>Probe lengths</b>	
5A <sup>(6)</sup>	Flexible Single Lead with weight, 4 mm	Flange / 1-in., 1½-in., 2-in. Thread	Min: 3 ft. 4 in. (1 m) Max: 115 ft. (35 m)
5B <sup>(7)</sup>	Flexible Single Lead with chuck, 4 mm	Flange / 1-in., 1½-in., 2-in. Thread	Min: 3 ft. 4 in. (1 m) Max: 115 ft. (35 m)
6A <sup>(8)</sup>	Flexible Single Lead with weight, 6 mm	Flange / 1-in., 1½-in., 2-in. Thread	Min: 3 ft. 4 in. (1 m) Max: 164 ft. (50 m)
6B <sup>(8)</sup>	Flexible Single Lead with chuck, 6 mm	Flange / 1-in., 1½-in., 2-in. Thread	Min: 3 ft. 4 in. (1 m) Max: 164 ft. (50 m)
<b>Probe length units</b>			
E	English (feet, in.)		★
M	Metric (meters, centimeters)		★

**Table 2: Rosemount 5303 Level for Solids Ordering Information (continued)**

<b>Total probe length (feet/m)<sup>(9)</sup></b>		
XXX	0-164 ft. or 0-50 m	★
<b>Total probe length (in./cm)<sup>(9)</sup></b>		
XX	0-11 in. or 0-99 cm	★
<b>Process connection - size / type (consult the factory for other process connections)</b>		
ASME flanges <sup>(10)</sup>		
AA	2 in. Class 150, RF (Raised Face Type)	★
AB	2 in. Class 300, RF (Raised Face Type)	★
BA	3 in. Class 150, RF (Raised Face Type)	★
BB	3 in. Class 300, RF (Raised Face Type)	★
CA	4 in. Class 150, RF (Raised Face Type)	★
CB	4 in. Class 300, RF (Raised Face Type)	★
DA	6 in. Class 150, RF (Raised Face Type)	
EN 1092-1 flanges <sup>(11)</sup>		
HB	DN50, PN40, Type A flat face	★
IA	DN80, PN16, Type A flat face	★
IB	DN80, PN40, Type A flat face	★
JA	DN100, PN16, Type A flat face	★
JB	DN100, PN40, Type A flat face	★
HI	DN50, PN40, Type E spigot face	
HP	DN50, PN16, Type C tongue face	
HQ	DN50, PN40, Type C tongue face	
IH	DN80, PN16, Type E spigot face	
II	DN80, PN40, Type E spigot face	
IP	DN80, PN16, Type C tongue face	
IQ	DN80, PN40, Type C tongue face	
JH	DN100, PN16, Type E spigot face	
JI	DN100, PN40, Type E spigot face	
JP	DN100, PN16, Type C tongue face	
JQ	DN100, PN40, Type C tongue face	
KA	DN150, PN16, Type A flat face	
JIS flanges <sup>(11)</sup>		
UA	50A, 10K, RF (Raised Face Type)	★
VA	80A, 10K, RF (Raised Face Type)	★
XA	100A, 10K, RF (Raised Face Type)	★
UB	50A, 20K, RF (Raised Face Type)	



**Table 2: Rosemount 5303 Level for Solids Ordering Information (continued)**

VB	80A, 20K, RF (Raised Face Type)		
XB	100A, 20K, RF (Raised Face Type)		
YA	150A, 10K, RF (Raised Face Type)		
YB	150A, 20K, RF (Raised Face Type)		
ZA	200A, 10K, RF (Raised Face Type)		
ZB	200A, 20K, RF (Raised Face Type)		
Threaded connections <sup>(10)</sup>		Probe type	
RA	1½-in. NPT thread	All	★
RC	2-in. NPT thread	All	★
RB	1-in. NPT thread	All	
SA	1½-in. BSP (G 1½-in.) thread	All	
SB	1-in. BSP (G 1-in.) thread	All	
<b>Hazardous locations certifications (see <a href="#">Product certifications</a>)</b>			
NA	No Hazardous Locations Certifications		★
E1 <sup>(12)</sup>	ATEX Flameproof		★
E3 <sup>(12)</sup>	China Flameproof		★
E5 <sup>(12)</sup>	USA Explosion-proof		★
E6 <sup>(12)</sup>	Canadian Explosion-proof		★
E7 <sup>(12)</sup>	IECEX Flameproof		★
I1	ATEX Intrinsic Safety		★
IA <sup>(13)</sup>	ATEX FISCO Intrinsic Safety		★
I3	China Intrinsic Safety		★
IC <sup>(13)</sup>	China FISCO Intrinsic Safety		★
I5	USA Intrinsic Safety and Non-Incendive		★
IE <sup>(13)</sup>	USA FISCO Intrinsic Safety		★
I6	Canadian Intrinsic Safety		★
IF <sup>(13)</sup>	Canadian FISCO Intrinsic Safety		★
I7	IECEX Intrinsic Safety		★
IG <sup>(13)</sup>	IECEX FISCO Intrinsic Safety		★
E2 <sup>(12)</sup>	INMETRO Flameproof		
EM <sup>(12)</sup>	Technical Regulations Customs Union (EAC) Flameproof		
I2	INMETRO Intrinsic Safety		
IB <sup>(13)</sup>	INMETRO FISCO Intrinsic Safety		
IM	Technical Regulations Customs Union (EAC) Intrinsic Safety		
IN <sup>(13)</sup>	Technical Regulations Customs Union (EAC) FISCO Intrinsic Safety		
E4 <sup>(12)(14)</sup>	Japan Flameproof		

**Table 2: Rosemount 5303 Level for Solids Ordering Information (continued)**

EP <sup>(12)</sup>	Republic of Korea Flameproof	
KA <sup>(12)</sup>	ATEX, USA, Canadian Flameproof/Explosion-proof	
KB <sup>(12)</sup>	ATEX, USA, IECEx Flameproof/Explosion-proof	
KC <sup>(12)</sup>	ATEX, Canadian, IECEx Flameproof/Explosion-proof	
KD <sup>(12)</sup>	USA, Canadian, IECEx Flameproof/Explosion-proof	
KE	ATEX, USA, Canadian Intrinsic Safety	
KF	ATEX, USA, IECEx Intrinsic Safety	
KG	ATEX, Canadian, IECEx Intrinsic Safety	
KH	USA, Canadian, IECEx Intrinsic Safety	
KI <sup>(13)</sup>	FISCO - ATEX, USA, Canadian Intrinsic Safety	
KJ <sup>(13)</sup>	FISCO - ATEX, USA, IECEx Intrinsic Safety	
KK <sup>(13)</sup>	FISCO - ATEX, Canadian, IECEx Intrinsic Safety	
KL <sup>(13)</sup>	FISCO - USA, Canadian, IECEx Intrinsic Safety	
N1	ATEX Type n	
N7	IECEx Type n	
<b>Options (include with selected model number)</b>		
<b>Display</b>		
M1	Integral digital display	★
<b>Communication</b>		
HR7	4–20 mA with digital signal based on HART 7 protocol	★
<b>Hydrostatic testing</b>		
P1 <sup>(15)</sup>	Hydrostatic testing	★
<b>Factory configuration</b>		
C1	Factory configuration (Configuration Data Sheet required with order, available at <a href="http://Emerson.com/Rosemount">Emerson.com/Rosemount</a> )	★
<b>Alarm limit configuration</b>		
C4	Namur alarm and saturation levels, high alarm	★
C5	Namur alarm and saturation levels, low alarm	★
C8	Low alarm <sup>(16)</sup> (standard Rosemount alarm and saturation levels)	★
<b>Welding documentation<sup>(17)</sup></b>		
Q66	Welding Procedure Qualification Record Documentation	
Q67	Welder Performance Qualification Record	
Q68	Welding Procedure Specification	
<b>Safety certifications</b>		
QS	Prior-use certificate of FMEDA Data. Only available with HART 4-20 mA output (output code H).	★
QT	Safety-certified to IEC 61508 with certificate of FMEDA data. Only available with HART 4-20 mA output (output code H).	★

**Table 2: Rosemount 5303 Level for Solids Ordering Information (continued)**

<b>Special certifications</b>		
Q4	Calibration Data Certification	★
Q8 <sup>(18)</sup>	Material Traceability Certification consistent with ISO10474-3.1:2013 / EN10204-3.1:2004	★
QG	GOST Primary Verification Certificate (only for end-destination country Russia)	
<b>Dye penetration test certificate</b>		
Q73	Certificate of Liquid Penetrant Inspection	★
<b>Positive material identification certificate</b>		
Q76	Positive Material Identification Certificate of Conformance	★
<b>Installation options</b>		
LS	Long stud 9.8 in (250 mm) for flexible single lead probe to prevent contact with wall/nozzle. Standard stud length is 3.9 in (100 mm) for probes 5A and 5B; 5.9 in. (150 mm) for probes 6A and 6B	★
BR	316L Mounting Bracket for 1½-in. NPT Process Connection (RA) (see <a href="#">Figure 47</a> )	
<b>Transient protection</b>		
T1	Transient Protection Terminal Block. Selectable with HART 4-20 mA output (output code H). Already included in all FOUNDATION Fieldbus variations.	★
<b>Diagnostic functionality</b>		
D01	FOUNDATION Fieldbus Diagnostics Suite (includes Signal Quality Metrics diagnostics)	★
DA1	HART Diagnostics Suite (includes Signal Quality Metrics diagnostics)	★
<b>Overfill prevention</b>		
U1 <sup>(19)</sup>	WHG Overfill Approval	★
<b>Extended product warranty</b>		
WR3 <sup>(20)</sup>	3-year limited warranty	★
WR5 <sup>(20)</sup>	5-year limited warranty	★
<b>Remote housing mounting (see <a href="#">Figure 48</a>)</b>		
B1	1m / 3.2 ft. Remote Housing Mounting Cable and 316L Bracket	
B2	2m / 6.5 ft. Remote Housing Mounting Cable and 316L Bracket	
B3	3m / 9.8 ft. Remote Housing Mounting Cable and 316L Bracket	
<b>Engineered solutions (see <a href="#">Engineered solutions</a>)</b>		
Rxxxx	Engineered Solutions beyond standard model codes. (Consult factory for details)	
<b>Example model string: 5303-H-A-1-S-1-V-6A-M-025-50-AA-I1-M1C1.</b>		
<b>E-025-05, means 25 ft. and 5 in. probe length. M-025-50, means 25.5 m.</b>		

- (1) Not available with explosion-proof or flameproof approvals.
- (2) Minimum temperature is -20 °C (-4 °F).
- (3) Not available with explosion-proof, flameproof, or type n approvals.
- (4) Process seal rating. Final rating depends on flange and O-ring selection. See "Temperature and pressure limits" on [Process temperature and pressure rating, Flange rating, Tri-Clamp® rating, and Plate design](#).
- (5) For other materials, consult the factory.
- (6) 0.79 lb (0.36 kg) standard weight for flexible single lead probe. L=5.5 in. (140 mm).
- (7) Extra length for fastening is added in the factory.
- (8) 1.2 lb (0.56 kg) standard weight for flexible single lead probe. L=5.5 in. (140 mm).

- (9) Probe weight included if applicable. Give the total probe length in feet and inches or meters and centimeters, depending on selected probe length unit. If tank height is unknown, please round up to an even length when ordering. Probes can be cut to exact length in field. Maximum allowable length is determined by process conditions. See [Total probe length](#) for more probe length guidance.
- (10) Available in 316L. For other materials, consult the factory.
- (11) Available in 316L and EN 1.4404. For other materials consult the factory.
- (12) Probes are intrinsically safe.
- (13) Requires FOUNDATION Fieldbus signal output (U<sub>i</sub> parameter listed in [Product certifications](#)).
- (14) G ½ in. SST cable gland is included in delivery.
- (15) Available for tank connection with flange.
- (16) The standard alarm setting is high.
- (17) Weldings in accordance with EN/ISO standards.
- (18) Certificate includes all pressure retaining wetted parts.
- (19) Cannot be combined with E2 (INMETRO Flameproof) or I2 (INMETRO Intrinsic Safety).
- (20) Rosemount extended warranties have a limited warranty of three or five years from date of shipment.

## Accessories

**Table 3: Accessories Ordering Information**

The starred options (★) represent the most common options and should be selected for best delivery. The non-starred offerings are subject to additional delivery lead time.

Weight kit			
03300-7001-0002	Weight kit flexible twin lead		
03300-7001-0003	Weight kit flexible 4 mm single lead		
03300-7001-0004	Weight kit flexible 6 mm single lead		
Centering discs for rigid single lead probe (d=0.3 in./8 mm) <sup>(1)(2)</sup>		Outer diameter	
03300-1655-0001	Kit, 2-in. Centering disc, SST	1.8 in. (45 mm)	★
03300-1655-0006	Kit, 2-in. Centering disc, PTFE	1.8 in. (45 mm)	★
03300-1655-0002	Kit, 3-in. Centering disc, SST	2.7 in. (68 mm)	★
03300-1655-0007	Kit, 3-in. Centering disc, PTFE	2.7 in. (68 mm)	★
03300-1655-0003	Kit, 4-in. Centering disc, SST	3.6 in. (92 mm)	★
03300-1655-0008	Kit, 4-in. Centering disc, PTFE	3.6 in. (92 mm)	★
03300-1655-0004	Kit, 6-in. Centering disc, SST	5.55 in. (141 mm)	
03300-1655-0009	Kit, 6-in. Centering disc, PTFE	5.55 in. (141 mm)	
03300-1655-0005	Kit, 8-in. Centering disc, SST	7.40 in. (188 mm)	
03300-1655-0010	Kit, 8-in. Centering disc, PTFE	7.40 in. (188 mm)	
Centering discs for rigid single lead probe (d=0.5 in./13 mm) <sup>(1)(2)</sup>		Outer diameter	
03300-1655-0301	Kit, 2-in. Centering disc, SST	1.8 in. (45 mm)	★
03300-1655-0306	Kit, 2-in. Centering disc, PTFE	1.8 in. (45 mm)	★
03300-1655-0302	Kit, 3-in. Centering disc, SST	2.7 in. (68 mm)	★
03300-1655-0307	Kit, 3-in. Centering disc, PTFE	2.7 in. (68 mm)	★
03300-1655-0303	Kit, 4-in. Centering disc, SST	3.6 in. (92 mm)	★
03300-1655-0308	Kit, 4-in. Centering disc, PTFE	3.6 in. (92 mm)	★
03300-1655-0304	Kit, 6-in. Centering disc, SST	5.55 in. (141 mm)	

**Table 3: Accessories Ordering Information (continued)**

03300-1655-0309	Kit, 6-in. Centering disc, PTFE	5.55 in. (141 mm)	
03300-1655-0305	Kit, 8-in. Centering disc, SST	7.40 in. (188 mm)	
03300-1655-0310	Kit, 8-in. Centering disc, PTFE	7.40 in. (188 mm)	
<b>Centering discs for flexible single/twin lead probes<sup>(1)(2)</sup></b>		<b>Outer diameter</b>	
03300-1655-1001	Kit, 2-in. Centering disc, SST	1.8 in. (45 mm)	★
03300-1655-1006	Kit, 2-in. Centering disc, PTFE	1.8 in. (45 mm)	★
03300-1655-1002	Kit, 3-in. Centering disc, SST	2.7 in. (68 mm)	★
03300-1655-1007	Kit, 3-in. Centering disc, PTFE	2.7 in. (68 mm)	★
03300-1655-1003	Kit, 4-in. Centering disc, SST	3.6 in. (92 mm)	★
03300-1655-1008	Kit, 4-in. Centering disc, PTFE	3.6 in. (92 mm)	★
03300-1655-1004	Kit, 6-in. Centering disc, SST	5.55 in. (141 mm)	
03300-1655-1009	Kit, 6-in. Centering disc, PTFE	5.55 in. (141 mm)	
03300-1655-1005	Kit, 8-in. Centering disc, SST,	7.40 in. (188 mm)	
03300-1655-1010	Kit, 8-in. Centering disc, PTFE	7.40 in. (188 mm)	
<b>Centering discs for mounting between segments (probe type 4S only)</b>		<b>Outer diameter</b>	
03300-1656-1002	2-in. Centering disc (1 pc), PTFE, Segmented rigid single lead	1.8 in. (45 mm)	
03300-1656-1003	3-in. Centering disc (1 pc), PTFE, Segmented rigid single lead	2.7 in. (68 mm)	
03300-1656-1004	4-in. Centering disc (1 pc), PTFE, Segmented rigid single lead	3.6 in. (92 mm)	
03300-1656-1006	6-in. Centering disc (1 pc), PTFE, Segmented rigid single lead	5.55 in. (141 mm)	
03300-1656-1008	8-in. Centering disc (1 pc), PTFE, Segmented rigid single lead	7.40 in. (188 mm)	
03300-1656-3002	2-in. Centering disc (3 pcs), PTFE, Segmented rigid single lead	1.8 in. (45 mm)	
03300-1656-3003	3-in. Centering disc (3 pcs), PTFE, Segmented rigid single lead	2.7 in. (68 mm)	
03300-1656-3004	4-in. Centering disc (3 pcs), PTFE, Segmented rigid single lead	3.6 in. (92 mm)	
03300-1656-3006	6-in. Centering disc (3 pcs), PTFE, Segmented rigid single lead	5.55 in. (141 mm)	
03300-1656-3008	8-in. Centering disc (3 pcs), PTFE, Segmented rigid single lead	7.40 in. (188 mm)	
03300-1656-5002	2-in. Centering disc (5 pcs), PTFE, Segmented rigid single lead	1.8 in. (45 mm)	
03300-1656-5003	3-in. Centering disc (5 pcs), PTFE, Segmented rigid single lead	2.7 in. (68 mm)	
03300-1656-5004	4-in. Centering disc (5 pcs), PTFE, Segmented rigid single lead	3.6 in. (92 mm)	
03300-1656-5006	6-in. Centering disc (5 pcs), PTFE, Segmented rigid single lead	5.55 in. (141 mm)	
03300-1656-5008	8-in. Centering disc (5 pcs), PTFE, Segmented rigid single lead	7.40 in. (188 mm)	
<b>Segmented rigid single lead probe spare part kit</b>			
03300-0050-0001	15.2 in. / 385 mm Segment for Top connection (1 pc)		
03300-0050-0002	31.5 in. / 800 mm Segment (1 pc)		
03300-0050-0003	31.5 in. / 800 mm Segment (3 pcs)		
03300-0050-0004	31.5 in. / 800 mm Segment (5 pcs)		
03300-0050-0005	31.5 in. / 800 mm Segment (12 pcs)		

**Table 3: Accessories Ordering Information (continued)**

<b>Vented flanges<sup>(3)(4)</sup></b>		
03300-1812-0092	Fisher™ 249B, 259B	
03300-1812-0093	Fisher 249C	
03300-1812-0091	Masoneilan™	
<b>Flushing connection rings<sup>(4)</sup></b>		
DP0002-2111-S6	2 in. ANSI, ¼ in. NPT connection	
DP0002-3111-S6	3 in. ANSI, ¼ in. NPT connection	
DP0002-4111-S6	4 in. ANSI/DN100, ¼ in. NPT connection	
DP0002-5111-S6	DN50, ¼ in. NPT connection	
DP0002-8111-S6	DN80, ¼ in. NPT connection	
<b>HART modem and cables</b>		
03300-7004-0001	MACTek® VIATOR® HART Modem and cables (RS232 connection)	★
03300-7004-0002	MACTek VIATOR HART Modem and cables (USB connection)	★
<b>Remote housing mounting spare part kit</b>		
03300-7006-0001	1 m / 3.2 ft. Remote Housing Mounting Cable and 316L Bracket	
03300-7006-0002	2 m / 6.5 ft. Remote Housing Mounting Cable and 316L Bracket	
03300-7006-0003	3 m / 9.8 ft. Remote Housing Mounting Cable and 316L Bracket	
<b>Verification reflector (high level supervision) spare part kit (requires Rosemount 5300 firmware version 2.H0 or later)</b>		
05300-7200-0001	For 3- to 8-in. pipe/chamber (inner diameter)	
05300-7200-0002	For tanks or 10-in. pipe/chamber (inner diameter) or wider	

- (1) If a centering disc is required for a flanged probe, the centering disc can be ordered with options Sx or Px in the model code. If a centering disc is required for a threaded connection, or as a spare part, it should be ordered using the item numbers listed in this table. Refer to [Table 33](#) for centering disc size recommendation for different pipe schedules.
- (2) To order a centering disc in a different material consult the factory.
- (3) 1-½ in. NPT threaded connection (RA) is required.
- (4) Not available with Country certification option code J1 (CRN).

# Specifications

## Performance specifications

### General

#### Reference conditions

Single Standard probe, 77 °F (25 °C) in water (DC=80) and ambient pressure in a 4-in. pipe using Trim Near Zone function.

#### Reference accuracy

± 0.12 in. (3 mm) or 0.03% of measured distance, whichever is greatest

For probes with spacers, the accuracy may deviate close to the spacers. Accuracy may be affected by remote housing.

#### Repeatability

± 0.04 in. (1 mm)

#### Ambient temperature effect

± 0.008 in. (0.2 mm) /°K or ± 30 ppm/°K of measured value, whichever is greatest<sup>(1)</sup>

#### Electromagnetic interference effect

- Shielded cable: ± 0.2 in. (5 mm)<sup>(2)</sup>
- Unshielded cable: ± 2 in. (50 mm)<sup>(2)</sup>

For FOUNDATION™ Fieldbus units it may be required to ground the signal cable shield at the power supply and transmitter to achieve optimum performance.

Thresholds may need to be adjusted, see section “Adjusting thresholds” of the Rosemount 5300 [Reference Manual](#) for general guidelines on manual threshold settings.

#### Update interval

Minimum 1 update per second

### Environment

#### Vibration resistance

- Aluminum housing: Level 1 IEC 60770-1/IEC 61298-3 ed 1 chapter 7, IACS E10
- Stainless Steel housing: IACS E10

#### Electromagnetic compatibility

Emission and Immunity: EMC directive 2014/30/EU, EN 61326-1:2013, and EN61326-3-1:2006.

NAMUR recommendations: NE21<sup>(3)</sup>

#### CE-mark

Complies with applicable directives (EMC, ATEX).

#### Built-in lightning protection

EN 61326, IEC 61000-4-5, level 2kV (6kV with T1 terminal block)

(1) For the BR5 option code with ambient temperatures between -67 °F (-55 °C) and -40 °F (-40 °C), the ambient temperature effect is ± 0.012 in. (0.3 mm) /°K or ± 45 ppm/°K of measured value, whichever is greatest.

(2) Deviation through electromagnetic interference according to EN 61326.

(3) Namur NE21 not available with option code QT.

### Contamination/product build-up

- Single lead probes are preferred when there is a risk of contamination (because build-up can result in the product bridging across the two leads for twin versions; between the inner lead and outer pipe for the coaxial versions).
- For viscous or sticky applications, PTFE probes are recommended. Periodic cleaning may also be required.
- For viscous or sticky applications, it is not recommended to use centering discs mounted along the single lead probe.
- Signal Quality Metrics (option code D01, or DA1) can be used to determine when to clean the probe. Transmitters equipped with the Diagnostics Suite option can calculate Signal Quality Metrics.

**Table 4: Maximum Recommended Viscosity and Contamination/Build-up**

Probe type	Maximum viscosity	Contamination/build-up
Single lead	8000 cP <sup>(1)(2)</sup>	Build-up allowed
Twin lead/Large coaxial	1500 cP	Thin build-up allowed, but no bridging
Coaxial	500 cP	Not recommended

(1) Consult your local Emerson representative in the case of agitation/turbulence and high viscous products.

(2) Be cautious in HTHP viscous or crystallizing media applications where temperature at instrument connection is significantly lower than process temperature with risk of coating in the upper part of probe that may reduce the measurement signal. Consider using HP or STD probes in such applications.

### Measuring range

See [Table 5](#) and [Table 6](#) for each probe's measuring range and minimum dielectric constant. Due to the measuring range depending on the application and factors described below, the values are a guideline for clean liquids. For more information, ask your local Emerson representative.

#### Note

For Remote Housing, see [Table 7](#) for the maximum recommended measuring range for different Remote Housing lengths, installation types, Dielectric Constants, and probe types.

Different parameters (factors) affect the echo and therefore the maximum measuring range differs depending on application according to:

- Disturbing objects close to the probe.
- Media with higher dielectric constant ( $\epsilon_r$ ) gives better reflection and allows a longer measuring range.
- Surface foam and particles in the tank atmosphere may affect measuring performance.
- Heavy product build-up or contamination on the probe should be avoided since it can reduce measuring range and might cause erroneous level readings.

**Table 5: Maximum Measuring Range**

Probe type	Maximum measuring range
Rigid single lead/segmented rigid single lead	9 ft. 10 in. (3 m) for 8 mm probes (code 4A) 19 ft. 8 in. (6 m) for 13 mm probes (code 4B) 32 ft. 9 in. (10 m) for 13 mm probes (code 4S)
Flexible single lead	164 ft. (50 m) <sup>(1)</sup>
Coaxial	19 ft. 8 in. (6 m)
Large coaxial	19 ft. 8 in. (6 m)
Rigid twin lead	9 ft. 10 in. (3 m)
Flexible twin lead	164 ft. (50 m)

(1) Maximum measuring range for Duplex 2205 probes type 5A and 5B is 105 ft. (32 m).



**Table 6: Minimum Dielectric Constant**

Probe type	Minimum dielectric constant			
	Std	HP	HTHP	C
Rigid single lead/ segmented rigid single lead	1.4 <sup>(1)(2)</sup> (1.25 if installed in a metallic bypass or stilling well)	1.6 <sup>(1)(2)</sup> (1.4 if installed in a metallic bypass or stilling well)		
Flexible single lead	1.4, up to 49 ft. (15 m) <sup>(1)</sup> 1.8, up to 82 ft. (25 m) <sup>(1)</sup> 2.0, up to 115 ft. (35 m) <sup>(1)(3)</sup> 3, up to 138 ft. (42 m) 4, up to 151 ft. (46 m) 6, up to 164 ft. (50 m)	1.6, up to 49 ft. (15 m) <sup>(1)</sup> 1.8, up to 82 ft. (25 m) <sup>(1)</sup> 2.0, up to 115 ft. (35 m) <sup>(1)(3)</sup> 3, up to 138 ft. (42 m) 4, up to 151 ft. (46 m) 6, up to 164 ft. (50 m)		
Coaxial	1.2	1.4	2.0	1.4
Large coaxial	1.2	1.4	N/A	1.4
Rigid twin lead	1.4	N/A	N/A	N/A
Flexible twin lead	1.4, up to 82 ft. (25 m) <sup>(1)</sup> 2.0, up to 115 ft. (35 m) <sup>(1)</sup> 2.5, up to 131 ft. (40 m) <sup>(1)</sup> 3.5, up to 148 ft. (45 m) 6, up to 164 ft. (50 m)	N/A	N/A	N/A

(1) Probe end projection software function will improve the minimum measurable dielectric constant. Consult the factory for details.

(2) May be lower depending on installation.

(3) Up to 49 ft. (15 m) for Duplex 2205 probes type 5A and 5B.

**Table 7: Remote Housing Measuring Range, ft. (m)**

		DC	Rigid single 8 mm	Rigid single 13 mm/ segmented rigid single	Flexible single	Coaxial/ Large coaxial	Rigid twin	Flexible twin
1 m remote housing <sup>(1)</sup>	Chamber / pipe installations < 4 in. (100 mm)	1.4	4 (1.25)	19 (6) <sup>(2)</sup>	33 (10) <sup>(2)(3)</sup>	19 (6)	10 (3) <sup>(2)</sup>	33 (10) <sup>(2)(3)</sup>
		2	10 (3) <sup>(2)</sup>	19 (6) <sup>(2)</sup>	33 (10) <sup>(2)(3)</sup>	19 (6)	10 (3) <sup>(2)</sup>	33 (10) <sup>(2)(3)</sup>
		80	10 (3)	19 (6) <sup>(2)</sup>	33 (10) <sup>(2)(3)</sup>	19 (6)	10 (3) <sup>(2)</sup>	33 (10) <sup>(2)(3)</sup>
	Tank installations	1.4	4 (1.25)	4 (1.25)	4 (1.25)	19 (6)	4 (1.25)	4 (1.25)
		2	4 (1.25)	4 (1.25)	4 (1.25)	19 (6)	4 (1.25)	98 (30) <sup>(2)</sup>
		80	10 (3) <sup>(2)</sup>	10 (3) <sup>(2)</sup>	159 (48.5) <sup>(2)</sup>	19 (6)	10 (3) <sup>(2)</sup>	159 (48.5) <sup>(2)</sup>
2 m remote housing <sup>(1)</sup>	Chamber / pipe installations < 4 in. (100 mm)	1.4	9 (2.75)	19 (6) <sup>(2)</sup>	33 (10) <sup>(2)(3)</sup>	19 (6)	10 (3) <sup>(2)</sup>	33 (10) <sup>(2)(3)</sup>
		2	10 (3) <sup>(2)</sup>	19 (6) <sup>(2)</sup>	33 (10) <sup>(2)(3)</sup>	19 (6)	10 (3) <sup>(2)</sup>	33 (10) <sup>(2)(3)</sup>
		80	10 (3)	19 (6)	33 (10) <sup>(2)(3)</sup>	19 (6)	10 (3) <sup>(2)</sup>	33 (10) <sup>(2)(3)</sup>
	Tank installations	1.4	9 (2.75)	9 (2.75)	9 (2.75)	19 (6)	9 (2.75)	9 (2.75)
		2	9 (2.75)	9 (2.75)	9 (2.75)	19 (6)	9 (2.75)	98 (30) <sup>(2)</sup>
		80	10 (3) <sup>(2)</sup>	10 (3) <sup>(2)</sup>	154 (47) <sup>(2)</sup>	19 (6)	10 (3) <sup>(2)</sup>	154 (47) <sup>(2)</sup>

**Table 7: Remote Housing Measuring Range, ft. (m) (continued)**

		DC	Rigid single 8 mm	Rigid single 13 mm/ segmented rigid single	Flexible single	Coaxial/ Large coaxial	Rigid twin	Flexible twin
3 m remote housing <sup>(1)</sup>	Chamber / pipe installations < 4 in. (100 mm)	1.4	10 (3)	19 (6)	33 (10) <sup>(2)(3)</sup>	19 (6)	10 (3) <sup>(2)</sup>	33 (10) <sup>(2)(3)</sup>
		2	10 (3)	19 (6)	33 (10) <sup>(2)(3)</sup>	19 (6)	10 (3) <sup>(2)</sup>	33 (10) <sup>(2)(3)</sup>
		80	10 (3)	19 (6)	33 (10) <sup>(2)(3)</sup>	19 (6)	10 (3) <sup>(2)</sup>	33 (10) <sup>(2)(3)</sup>
	Tank installations	1.4	10 (3)	14 (4.25)	14 (4.25)	19 (6)	10 (3) <sup>(2)</sup>	14 (4.25)
		2	10 (3)	14 (4.25)	14 (4.25)	19 (6)	10 (3) <sup>(2)</sup>	98 (30) <sup>(2)</sup>
		80	10 (3)	19 (6) <sup>(2)</sup>	149 (45.5) <sup>(2)</sup>	19 (6)	10 (3) <sup>(2)</sup>	149 (45.5) <sup>(2)</sup>

(1) Validated for ambient temperature range -40 °F to 185 °F (-40 °C to 85 °C).

(2) Accuracy may be affected up to + 1.2 in. (30 mm).

(3) Required chamber/pipe size is 3 or 4 in. (75 - 100 mm).

**Interface measuring range**

The maximum allowable upper product thickness/measuring range is primarily determined by the dielectric constants of the two liquids.

Typical applications include interfaces between oil/oil-like and water/water-like liquids, with a low (<3) dielectric constant for the upper product and a high (>20) dielectric constant for the lower product. For such applications, the maximum measuring range is limited by the length of the coaxial, large coaxial, rigid twin, and rigid single lead probes.

For flexible probes, the maximum measuring range is reduced by the maximum upper product thickness, according to the diagram below. However, characteristics may vary between the different applications. Maximum distance to the interface is 164 ft. (50 m) minus the maximum upper product thickness.

**Figure 2: Maximum Upper Product Thickness for the Flexible Single Lead Probe**

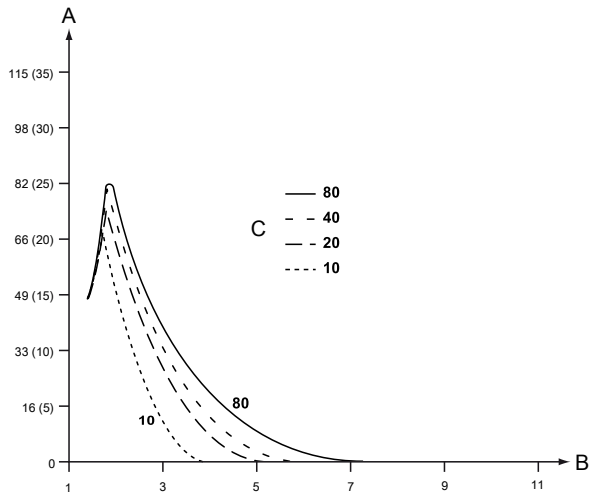

- A. Maximum upper product thickness, ft. (m)
- B. Upper product dielectric constant
- C. Lower product dielectric constant

**Figure 3: Maximum Upper Product Thickness for the Flexible Twin Lead Probe**

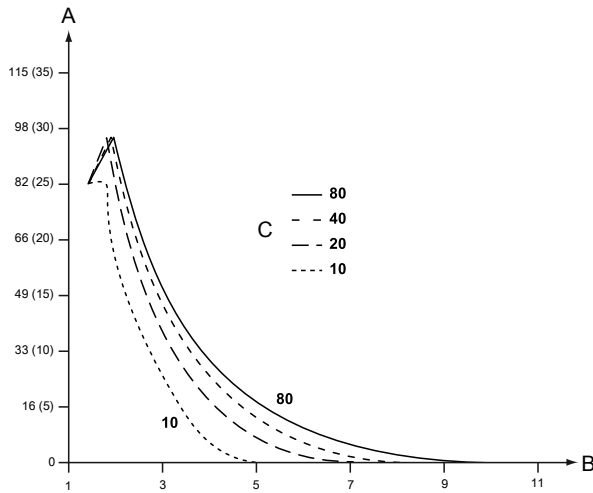

- A. Maximum upper product thickness, ft. (m)
- B. Upper product dielectric constant
- C. Lower product dielectric constant

**Accuracy over measuring range**

The measuring range depends on probe type, dielectric constant of the product and installation environment, and is limited by the Blind Zones at the very top and bottom of the probe. In the Blind Zones, the accuracy exceeds  $\pm 1.18$  in. (30 mm), and measurements may not be possible. Measurements close to the Blind Zones will have reduced accuracy.

The following conditions will impact the Blind Zones:

- If the single lead probes or twin probes are installed in a nozzle, the nozzle height shall be added to the specified Upper Blind Zone.
- The measuring range for the PTFE covered flexible single lead probe includes the weight when measuring on a high dielectric media.
- When using a metallic centering disc, the Lower Blind Zone is 8 in. (20 cm), including weight if applicable. When using a PTFE centering disc, the Lower Blind Zone is not affected.

Figure 5, Figure 7, and Figure 6 illustrate the accuracy over measuring range at reference condition with alternating probe types and varying dielectric constant of the product.

Figure 4: Blind Zones

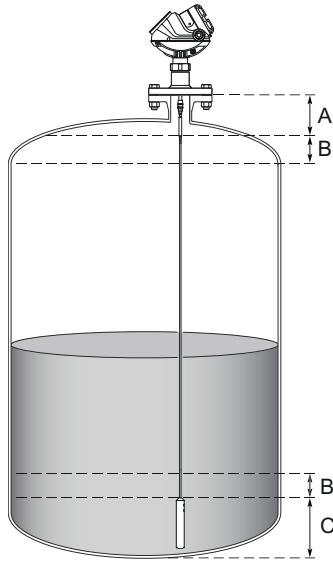

- A. Upper Blind Zone
- B. Reduced accuracy
- C. Lower Blind Zone

**Note**

Measurements may not be possible in the Blind Zones, and measurements close to the Blind Zones will have reduced accuracy. Therefore, the 4-20 mA points should be configured outside these zones.

Figure 5: Accuracy Over Measuring Range for Single Lead Probes (Rigid/Segmented Rigid/Flexible)

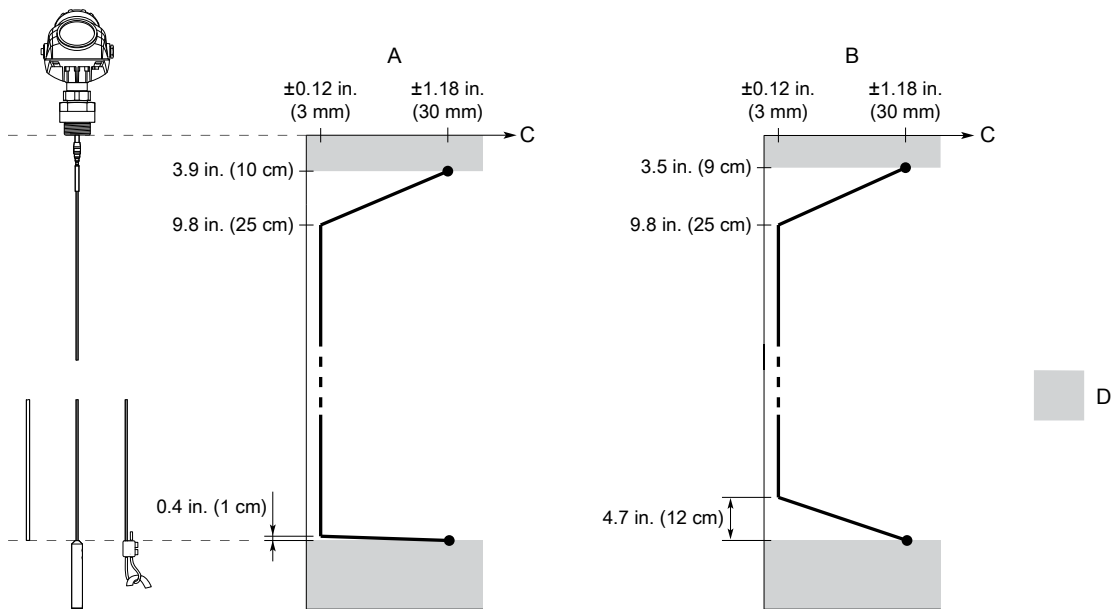

- A. Water (DC = 80)
- B. Oil (DC = 2)
- C. Accuracy
- D. Blind Zone

**Figure 6: Accuracy Over Measuring Range for Twin Lead Probes**

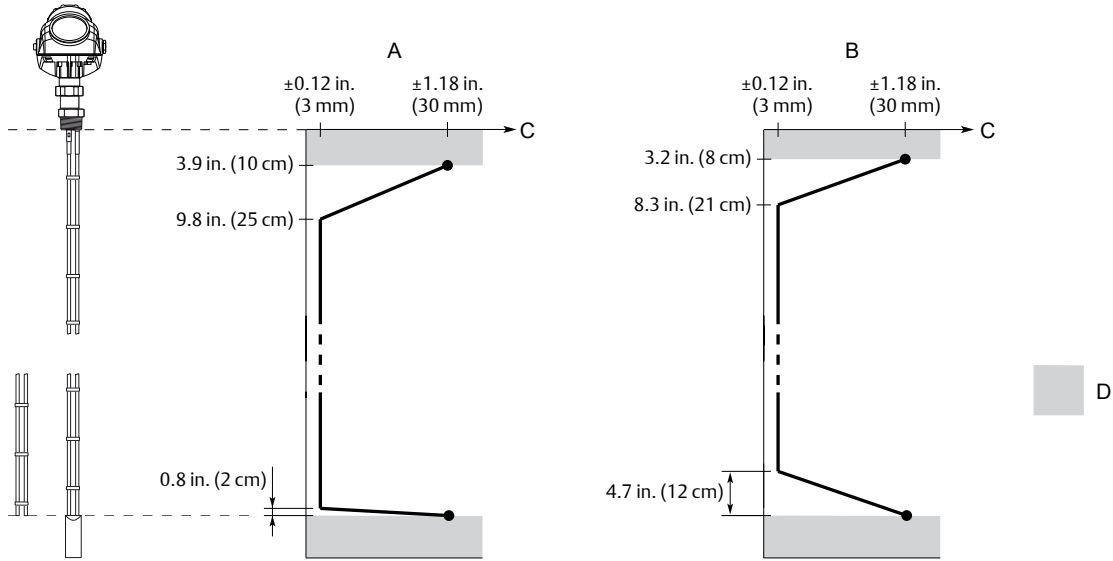

- A. Water (DC = 80)
- B. Oil (DC = 2)
- C. Accuracy
- D. Blind Zone

**Figure 7: Accuracy Over Measuring Range for Coaxial Probe**

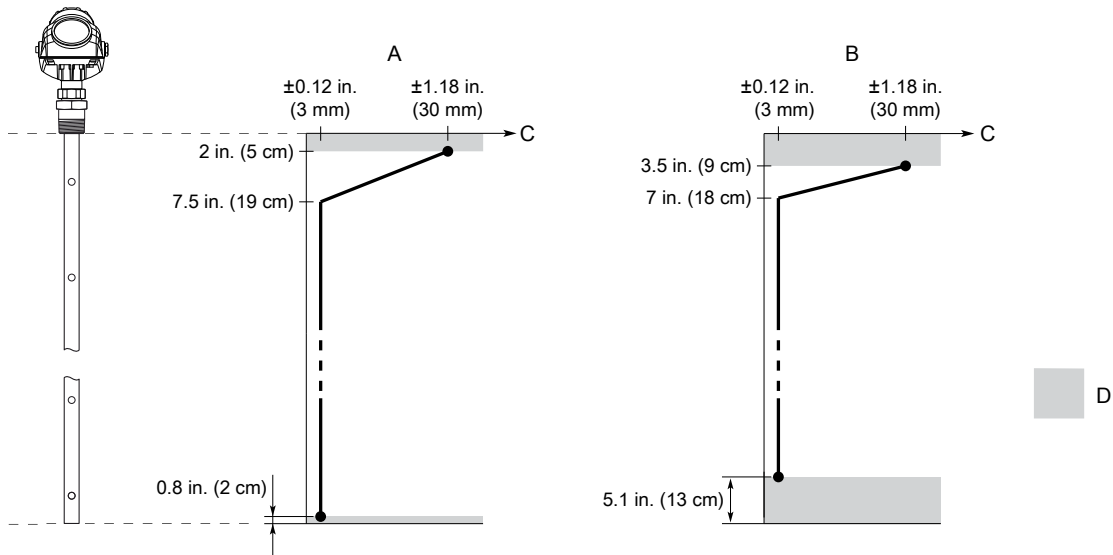

- A. Water (DC = 80)
- B. Oil (DC = 2)
- C. Accuracy
- D. Blind Zone

Figure 8: Accuracy Over Measuring Range for Large Coaxial Probe

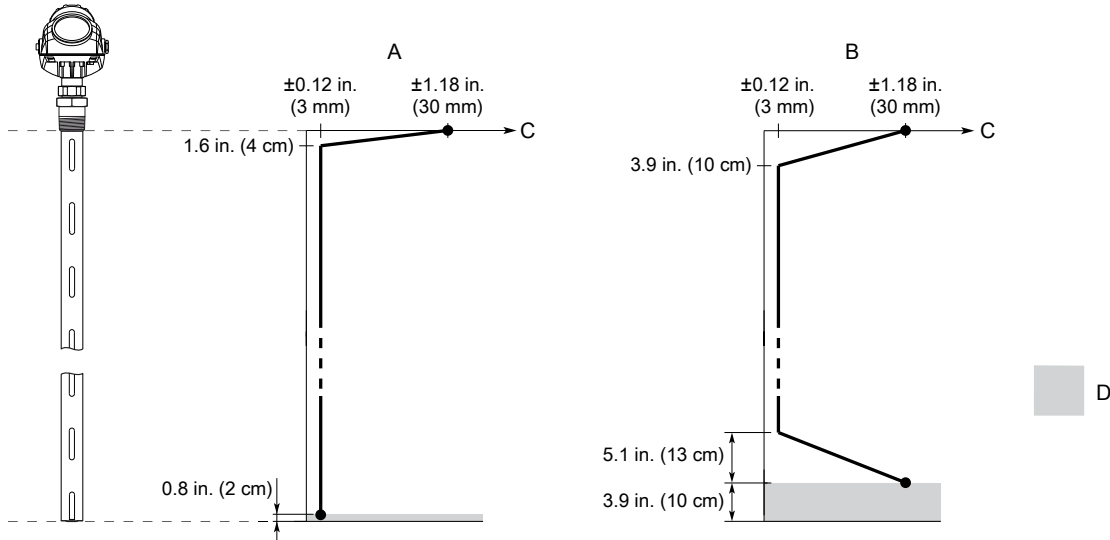

- A. Water (DC = 80)
- B. Oil (DC = 2)
- C. Accuracy
- D. Blind Zone

## Functional specifications

### General

#### Field of application

Liquids and semi-liquids level and/or liquid/liquid interfaces or solids level

- Model 5301, for liquid level or submerged interface measurements
- Model 5302, for liquid level and interface measurements
- Model 5303, for solid level measurements

#### Measurement principle

Time Domain Reflectometry (TDR)

#### Related information

[Measurement principle](#)

#### Microwave output power

Nominal 300  $\mu$ W, Max. 45 mW

#### EMC

FCC part 15 subpart B and EMC Directive (2014/30/EU). Considered to be an unintentional radiator under the Part 15 rules.

#### Humidity

0 to 100% relative humidity

**Start-up time**

< 40 s<sup>(4)</sup>

(4) The start-up time is extended with five additional minutes for option code BR5 at temperatures below -40 °F (-40 °C). Refer to [Figure 10](#).

**Start-up sequence**

For the Rosemount™ 5300, as default, the radar will first go to Low Alarm current for nine seconds during boot-up followed by nine seconds of High Alarm current. After that measurement is re-established and the 4-20mA output settles at the actual level value.<sup>(5)</sup>

If a different start-up behavior is preferred, contact your local Emerson representatives.

**Figure 9: Start-Up Sequence**

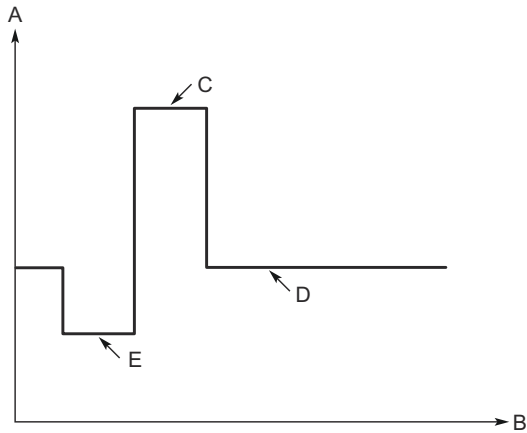

- A. Current, mA
- B. Time, s
- C. High Alarm current (Rosemount or Namur value, according to configuration)
- D. Actual level value
- E. Low Alarm current (Rosemount or Namur value, according to configuration)

**Figure 10: Start-Up Sequence for Option Code BR5 with Ambient Temperatures Below -40 °F (-40 °C)**

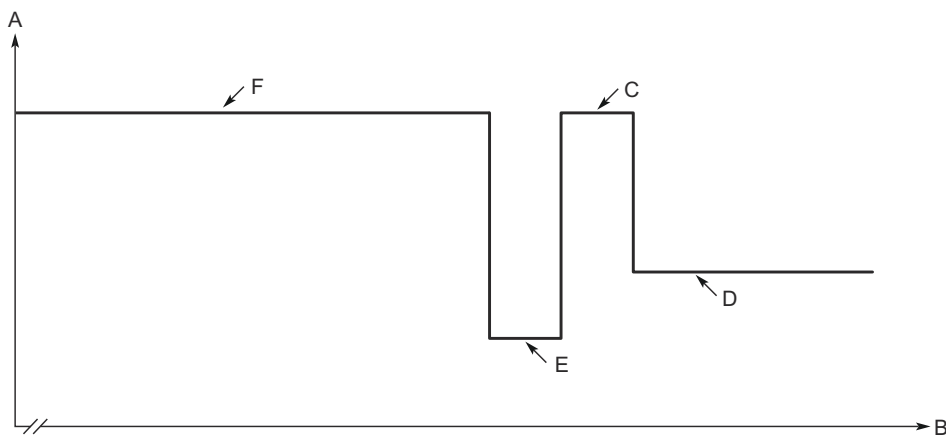

- A. Current, mA
- B. Time, s
- C. High Alarm current (Rosemount or Namur value, according to configuration)
- D. Actual level value
- E. Low Alarm current (Rosemount or Namur value, according to configuration)
- F. High Alarm current (Rosemount or Namur value, according to configuration), extended start-up time (five additional minutes)

(5) The start-up time is extended with five additional minutes for option code BR5 at temperatures below -40 °F (-40 °C). Refer to [Figure 10](#).



### 4-20 mA HART® (output option code H)

#### Output

Two-wire, 4-20 mA. Digital process variable is superimposed on 4-20 mA signal, and available to any host that conforms to the HART protocol. The digital HART® signal can be used in multidrop mode.

The default output is HART Revision 5. To order HART Revision 7 factory configured, add option code HR7. The device can also be field configured to HART Revision 7 if needed.

#### Signal wiring

Recommended output cabling is twisted shielded pairs, 24-12 AWG.

#### Rosemount 333 HART® Tri-Loop™

By sending the digital HART signal to the optional HART Tri-Loop, it is possible to have up to three additional 4–20 mA analog signals.



See the Rosemount 333 HART Tri-Loop [Product Data Sheet](#) for additional information.

#### Emerson Wireless 775 THUM™ Adapter

The optional Emerson Wireless 775 THUM Adapter can be mounted directly on the transmitter or by using a remote mounting kit.



IEC 62591 (*WirelessHART®*) enables access to multivariable data and diagnostics, and adds wireless to almost any measurement point.

See the Emerson Wireless 775 THUM Adapter [Product Data Sheet](#) and [Technical Note](#) for additional information.

#### Power requirements

Terminals in the transmitter housing provide connections for signal cables. The Rosemount 5300 Level Transmitter is loop-powered and operates with the following power supplies:

**Table 8: External Power Supply for HART**

Approval type	Input voltage (U <sub>i</sub> ) <sup>(1)</sup>
None	16 - 42.4 Vdc
Non-sparking/Energy Limited	16 - 42.4 Vdc
Intrinsically Safe	16 - 30 Vdc
Explosion-proof/Flameproof	20 - 42.4 Vdc

(1) Reverse polarity protection.

**Figure 11: External Power Supply for HART**

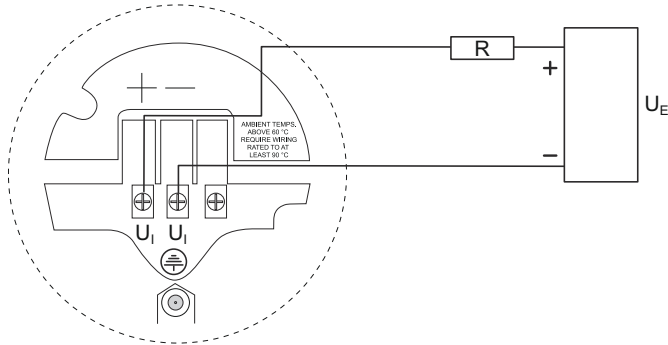

R = Load Resistance ( $\Omega$ )

$U_E$  = External Power Supply Voltage (Vdc)

$U_i$  = Input Voltage (Vdc)

For Explosion-proof/Flameproof installations the Rosemount 5300 Level Transmitters have a built-in barrier; no external barrier needed.<sup>(6)</sup>

When a THUM Adapter is fitted, it adds a maximum drop of 2.5 Vdc in the connected loop.

**Table 9: Minimum Input Voltage ( $U_i$ ) at Different Currents**

Hazardous approval	Current	
	3.75 mA	21.75 mA
	Minimum input voltage ( $U_i$ )	
Non-hazardous installations, intrinsically safe installations and Non-sparking installations	16 Vdc	11 Vdc
Explosion-proof/flameproof installations	20 Vdc	15.5 Vdc

**Signal on alarm**

	High	Low
Standard	21.75 mA	3.75 mA
Namur NE43	22.50 mA	3.60 mA

**Saturation levels**

	High	Low
Standard	20.8 mA	3.9 mA
Namur NE43	20.5 mA	3.8 mA

**FOUNDATION™ Fieldbus (output option code F)**

**Power requirements**

Terminals in the transmitter housing provide connections for signal cables. The Rosemount 5300 Level Transmitter is powered over FOUNDATION™ Fieldbus with standard fieldbus power supplies. The transmitter operates with the following power supplies:

(6) An external galvanic isolator is always recommended to be used for Flameproof/ Explosion-proof installations.

**Table 10: External Power Supply for FOUNDATION Fieldbus**

Approval type	Power supply (Vdc)
None	9 - 32
Non-sparking/Energy limited	9 - 32
Intrinsically Safe	9 - 30
FISCO	9 - 17.5
Explosion-proof/flameproof	16 - 32

For Explosion-proof/Flameproof installations the Rosemount 5300 Level Transmitters have a built-in barrier; no external barrier needed.<sup>(7)</sup>

**Quiescent current draw**

22 mA

**Blocks and execution time**

Block	Execution time
1 Resource	N/A
3 Transducer	N/A
6 Analog Input (AI)	10 ms
1 Proportional/Integrate/Derivate (PID)	15 ms
1 Signal Characterizer (SGCR)	10 ms
1 Integrator (INT)	10 ms
1 Arithmetic (ARTH)	10 ms
1 Input Selector (ISEL)	10 ms
1 Control Selector (CS)	10 ms
1 Output Splitter (OS)	10 ms

**FOUNDATION Fieldbus class (basic or Link Master)**

Link Master (LAS)

**FOUNDATION Fieldbus instantiation**

Yes

**Conforming FOUNDATION™ Fieldbus**

ITK 6.0.1

**FOUNDATION Fieldbus alerts**

- Field diagnostics alerts
- Plantweb™ alerts

*(7) An external galvanic isolator is always recommended to be used for Flameproof/ Explosion-proof installations.*

### Modbus® (output option code M)

#### Output

The RS-485 Modbus version communicates by Modbus RTU, Modbus ASCII, and Levelmaster protocols. 8 data bits, 1 start bit, 1 stop bit, and software selectable parity.

- Baud Rate** 1200, 2400, 4800, 9600 (default), and 19200 bits/s
- Address Range** 1 to 255 (default device address is 246)

HART communication is used for configuration via the HART terminals or tunneling via the RS-485.

#### External power supply

The input voltage  $U_i$  for Modbus is 8-30 Vdc (max. rating).

#### Wiring diagram

Figure 12: Wiring Diagram for RS-485 with Modbus®

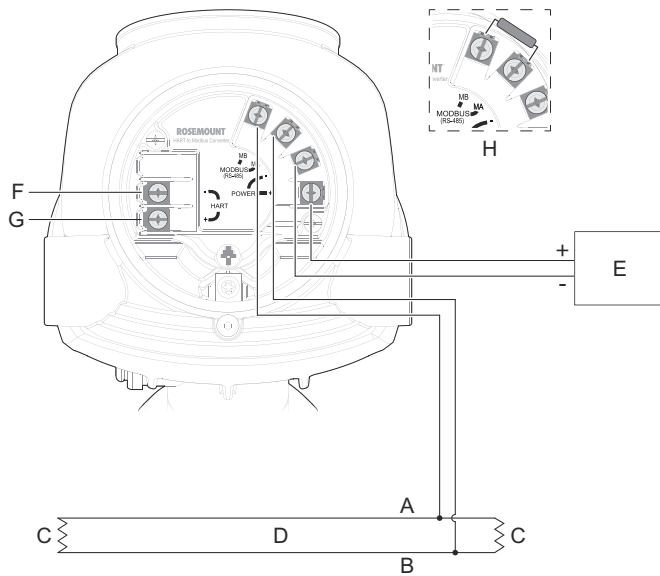

- A. "A" line
- B. "B" line
- C. 120 Ω
- D. RS-485 Bus
- E. Power supply
- F. HART -
- G. HART +
- H. If it is the last transmitter on the bus, connect the 120 Ω termination resistor.

#### Note

Rosemount 5300 Level Transmitters with Flameproof/Explosion-proof output have a built-in barrier; no external barrier needed.<sup>(8)</sup>

#### Power consumption

- < 0.5 W (with HART address=1)
- < 1.2 W (incl. four HART slaves)

<sup>(8)</sup> An external galvanic isolator is always recommended to be used for Flameproof/Explosion-proof installations.

**Note**

The Rosemount 5300 Level Transmitter with Modbus protocol is configured to HART address 1 at factory. This reduces power consumption by locking the analog output at 4 mA.

---

**Display and configuration****Integral display (option code M1)**

The integral digital display can toggle between: level, distance, volume, internal temperature, interface distance, interface level, peak amplitudes, interface thickness, percentage of range, analog current out.

---

**Note**

The display cannot be used for configuration purposes.

---

**Remote display**

Data can be read remotely using the Rosemount 751 Field Signal Indicator for 4-20 mA / HART® (see [Product Data Sheet](#)), or the Rosemount 752 Remote Indicator for FOUNDATION™ Fieldbus (see [Product Data Sheet](#)).

**Configuration tools**

- Rosemount Radar Master (included in the delivery)
- Device Descriptor (DD) based systems, e.g. AMS Device Manager, handheld communicator, and DeltaV™
- Device Type Manager (DTM™) based systems (compliant with version 1.2 of the FDT®/DTM specification), supporting configuration in for instance Yokogawa Fieldmate/PRM, E+H FieldCare®, and PACTware™

**Output units**

- Level, Interface and Distance: ft., in., m, cm, or mm
- Level Rate: ft./s, m/s, in./min, m/h
- Volume: ft.<sup>3</sup>, in.<sup>3</sup>, US gals, Imp gals, barrels, yd<sup>3</sup>, m<sup>3</sup>, or liters
- Temperature: °F and °C

## Output variables

**Table 11: Output Variables**

Variable	5301	5302	5303	PV, SV, TV, QV
Level	✓	✓	✓	✓
Distance to Level (Ullage)	✓	✓	✓	✓
Level Rate	✓	✓	✓	✓
Signal Strength	✓	✓	✓	✓
Volume	✓	✓	✓	✓
Internal Temperature	✓	✓	✓	✓
Interface Level	(✓) <sup>(1)</sup>	✓	N/A	✓
Interface Distance	(✓) <sup>(1)</sup>	✓	N/A	✓
Interface Level Rate	(✓) <sup>(1)</sup>	✓	N/A	✓
Interface Signal Strength	(✓) <sup>(1)</sup>	✓	N/A	✓
Upper Layer Thickness	(✓) <sup>(1)</sup>	✓	N/A	✓
Lower Volume	(✓) <sup>(1)</sup>	✓	N/A	✓
Upper Volume	(✓) <sup>(1)</sup>	✓	N/A	✓
Signal Quality	✓	✓	✓	(✓) <sup>(2)</sup>
Surface/Noise Margin	✓	✓	✓	(✓) <sup>(2)</sup>
Vapor DC	✓	N/A	N/A	(✓) <sup>(2)</sup>
Analog Output Current <sup>(3)(4)</sup>	✓	✓	✓	N/A
% of Range <sup>(4)</sup>	✓	✓	✓	N/A

(1) Interface measurement only for fully submerged probe, see [Figure 18](#).

(2) Not available as primary variable.

(3) Not available for FOUNDATION™ Fieldbus, Modbus® Signal Output, or for HART® units in fixed current mode.

(4) LCD display variable only.

## Damping

0-60 s (2 s, default value)

## Diagnostics

### General

Transmitter diagnostics with alerts include hardware and software errors, electronics temperature, probe missing, and invalid measurement and configuration error diagnostics. In addition to this, echo curve and variable logging including signal strength facilitate easy on-line troubleshooting.

### Diagnostics Suite (option code D01 or DA1)

### Signal Quality Metrics

Diagnostics package that monitors the relations between surface, noise and threshold. The function can be used to detect abnormal conditions in the process such as probe contamination or sudden loss of signal strength. Signal Quality Metrics parameters are available as Output Variables in Rosemount Radar Master, and can be sent to Distributed Control System (DCS) to trigger an alarm.

**Verification reflector (option code HL1, HL2, or HL3)**

The reflector, which is available with single lead flexible probes, is used to test and continuously verify that the transmitter is functioning properly in both tank and chamber/pipe installations. Compared to traditional diagnostics that only monitor the transmitter electronics, the reflector can also be used to diagnose the upper parts of the probe inside the tank for e.g. build-up, corrosion monitoring and other process related conditions.

**Figure 13: Verification Reflector**

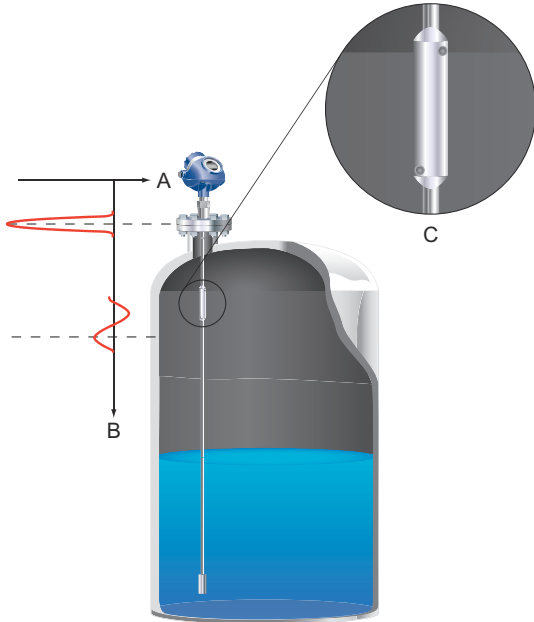

- A. Amplitude
- B. Distance
- C. Reflector

The primary use-cases for the reflector are:

- Verification of transmitter and probe (i.e. proof-testing)
- High level supervision (i.e. continuous monitoring of high level condition)

**Verification**

During commissioning, the location and amplitude characteristics of the reflector are stored in the transmitter. When the test procedure is later initiated, the stored reflector data is compared to the current measurement to verify the integrity of the measurement electronics and upper part of the probe.

During the test, the transmitter will output a level corresponding to the reflector position, which can be used to verify the integrity of the transmitter output.

**High level supervision**

Additionally, the reflector’s unique echo characteristics aid the transmitter to locate a liquid surface above the reflector, thereby offering increased reliability to detect high level conditions at a user selectable limit.

The transmitter continuously monitors the status of the reflector and abnormal conditions generate alarms and alerts as appropriate.

**Limitations for verification reflector**

<b>Application</b>	Not to be used in fully submerged applications
<b>Minimum dielectric constant</b>	2.4 (for option code HL1) 2.0 (for option codes HL2 and HL3)

**More information**

For more information and installation requirements, refer to the High Level Supervision [Manual Supplement](#).

**Process temperature and pressure rating**

Figure 14 gives the maximum process temperature (measured at the lower part of the flange or threaded connection) and pressure rating for tank connections:

- Standard (model code S)
- HTHP - High Temperature and High Pressure (model code H)
- HP - High Pressure (model code P)
- C - Cryogenic temperature (model code C)

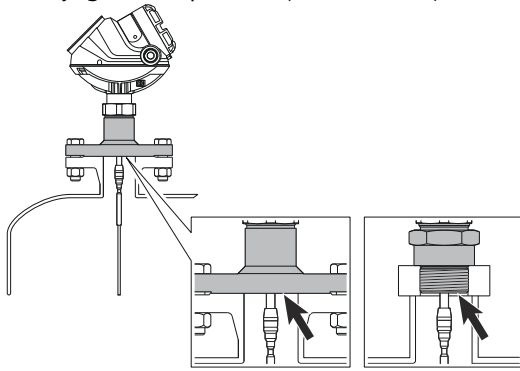

For standard tank connection, final rating may be lower depending on flange, material of construction, and O-ring selection. [Table 12](#) gives the temperature ranges for standard tank seals with different O-ring materials.

**Table 12: Temperature Ranges for Standard Tank Seals with Different O-ring Material**

O-ring material	Temperature °F (°C) in air	
	Minimum <sup>(1)</sup>	Maximum
Viton® Fluoroelastomer	5 (-15)	302 (150)
Ethylene Propylene (EPDM)	-40 (-40)	266 (130)
Kalrez® 6375 Perfluoroelastomer	14 (-10)	302 (150)
Nitrile Butadiene (NBR)	-31 (-35)	230 (110)
Low Temperature Viton Fluoroelastomer	-22 (-30)	302 (150)
Fluorosilicone (FVMQ)	-49 (-45)	302 (150)

(1) The O-ring can be stored at lower temperatures (refer to [Table 13](#)).

**Note**

Always check the chemical compatibility of the O-ring material with your application. If the O-ring material is not compatible with its chemical environment, the O-ring may eventually malfunction.

No wetted O-rings are used in the HTHP, HP, and C versions. Final rating may be lower depending on flange and material of construction selection.



**Figure 14: Process Temperature and Pressure - Max Rating**

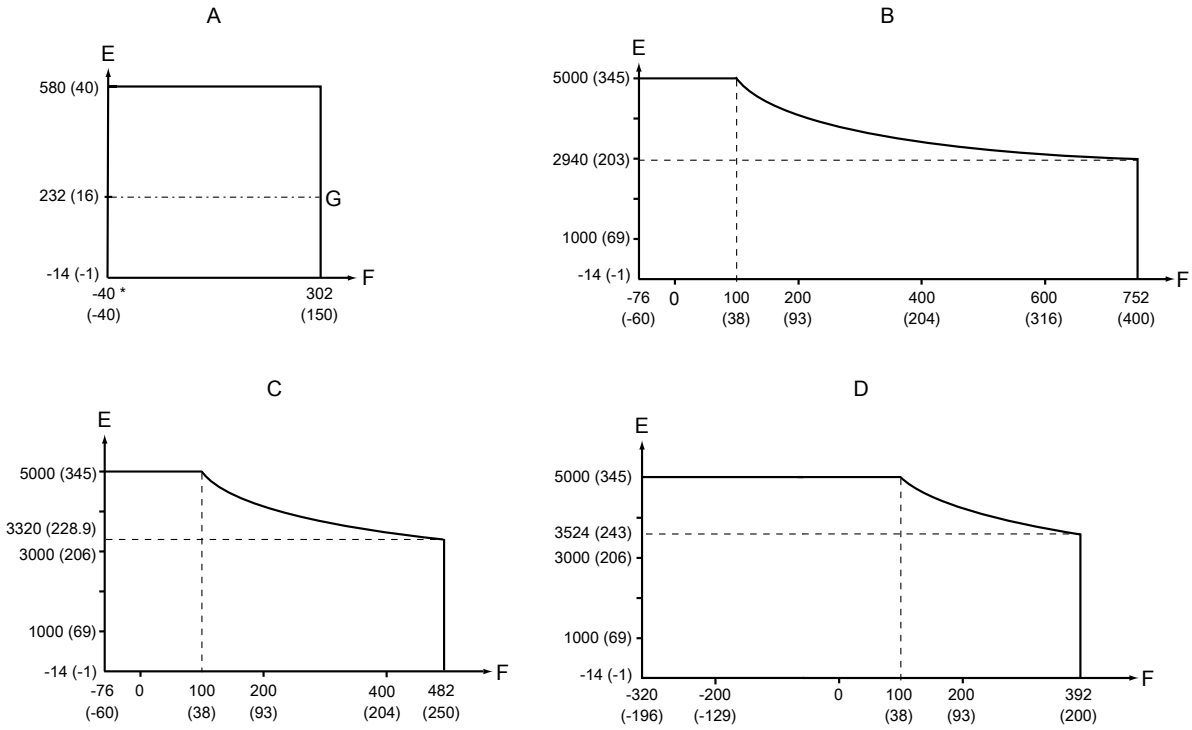

- A. Standard tank connections
- B. HTHP tank connections
- C. HP tank connections
- D. C tank connections
- E. Pressure psig (bar)
- F. Temperature °F (°C)
- G. PTFE covered probe and flange

\* -49 °F (-45 °C) depending on O-ring selection

**Temperature limits**

The maximum and minimum ambient temperature for the electronics depends on the process temperature (as described by Figure 15 and Figure 16) and on the approval (see Product certifications).

**Figure 15: Ambient Temperature vs. Process Temperature**

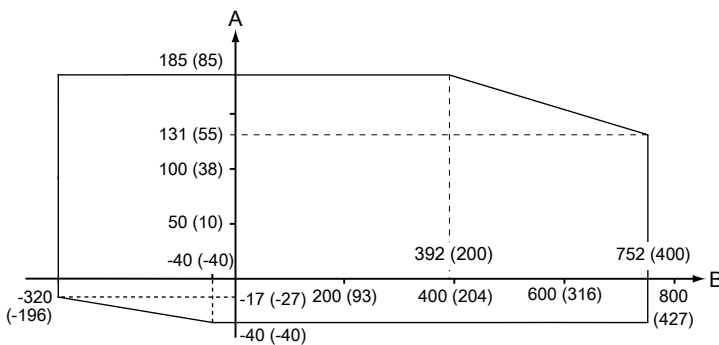

- A. Ambient temperature °F (°C)
- B. Process temperature °F (°C)

**Figure 16: Ambient Temperature vs. Process Temperature with Option Code BR5**

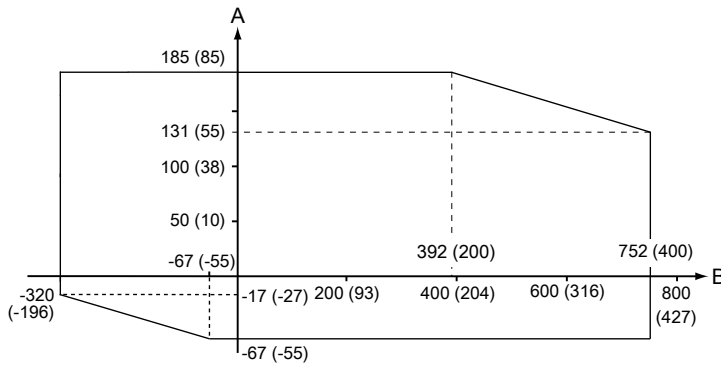

A. Ambient temperature °F (°C)  
 B. Process temperature °F (°C)

**Note**

Nozzle insulation for the HTHP version (Operating Temperature and Pressure code H) should not exceed 4 in. (10 cm) of height above the flange.

**Note**

In applications where the ambient temperature exceeds the limits of the electronics, a Remote Mounting connection can be used. The maximum temperature for the Remote Mounting connection at the vessel connection point is 302 °F (150 °C).

**Table 13: Ambient Temperature Limits**

Description	Operating limit	Storage limit
Without integral display	-40 °F to 185 °F (-40 °C to 85 °C)	-58 °F to 194 °F (-50 °C to 90 °C)
With integral display	-40 °F to 158 °F (-40 °C to 70 °C) <sup>(1)</sup>	-40 °F to 185 °F (-40 °C to 85 °C)
Option code BR5 without integral display	-67 °F to 185 °F (-55 °C to 85 °C)	-76 °F to 194 °F (-60 °C to 90 °C)
Option code BR5 with integral display	-67 °F to 158 °F (-55 °C to 70 °C) <sup>(1)</sup>	-76 °F to 185 °F (-60 °C to 85 °C)

(1) Integral display may not be readable and device display updates will be slower at temperatures below -4 °F (-20 °C).

**Flange rating**

The flanges, except the Fisher™ and Masoneilan™ flanges, are triple certified for the materials 316, 316L, and EN 1.4404.

**ASME flange rating**

316 up to Class 1500 flanges according to ASME B16.5 Table 2-2.2 and 316L for Class 2500 flanges according to ASME B16.5 Table 2-2.3:

- Standard: Max. 302 °F/580 psig (150 °C/40 Bar)
- HP: Class 2500 up to max 482 °F (250 °C)
- C: Class 2500 up to max 392 °F (200 °C)
- HTHP: Class 2500 up to max 752 °F (400 °C)

Alloy C-276 (UNS N10276) according to ASME B16.5 Table 2-3.8:

- Standard: Max. 302 °F/580 psig (150 °C/40 Bar)
- HP: Class 1500 up to max 482 °F (250 °C)
- HTHP: Class 1500 up to max 752 °F (400 °C)

Duplex 2205 (UNS S31803) according to ASME B16.5 Table 2-2.8:

- Standard: Max. 302 °F/580 psig (150 °C/40 Bar)
- HP: Class 1500, -51 °F (-46 °C) up to max 482 °F (250 °C)
- HTHP: Class 1500, -51 °F (-46 °C) up to max 599 °F (315 °C)

### EN flange rating

EN 1.4404 according to EN 1092-1 material group 13E0:

- Standard: Max. 302 °F/580 psig (150 °C/40 Bar)
- HP: PN 320 up to max 482 °F (250 °C)
- C: PN 320 up to max 392 °F (200 °C)
- HTHP: PN 320 up to max 752 °F (400 °C)

Alloy C-276 (UNS N10276) according to EN 1092-1 material group 12E0:

- Standard: Max. 302 °F/580 psig (150 °C/40 Bar)
- HP: PN 320 up to max 482 °F (250 °C)
- HTHP: PN 320 up to max 752 °F (400 °C)

Duplex 2205 (EN 1.4462) according to EN 1092-1 material group 16E0:

- Standard: Max. 580 psig (40 Bar), -22 °F (-30 °C) up to max 302 °F (150 °C)<sup>(9)</sup>
- HP: PN 320, -22 °F (-30 °C) up to max 482 °F (250 °C)<sup>(9)</sup>
- HTHP: PN 320, -22 °F (-30 °C) up to max 482 °F (250 °C)<sup>(9)</sup>

### JIS flange rating

316 according to JIS B2220 material group 2.2:

- Standard: Max. 302 °F/580 psig (150 °C/40 Bar)
- HP: Max. temp. 250 °C. Final rating depends on flange.
- C: Max. temp. 200 °C. Final rating depends on flange.
- HTHP: Max. temp. 400 °C. Final rating depends on flange.

### Fisher and Masoneilan flange rating

316 according to ASME B16.5 Table 2-2.2:

- Standard: Max. 302 °F/580 psig (150 °C/40 Bar)
- HP: Class 600 up to max 250 °C
- C: Class 600 up to max 200 °C
- HTHP: Class 600 up to max 400 °C

### Tri-Clamp® rating

Tri-Clamp is available for the Standard Temperature and Pressure seal.

(9) Minimum temperature limit due to EN13445-2.

**Table 14: Tri-Clamp Rating**

Size	Maximum pressure (bar) <sup>(1)</sup>
1½-in. (37.5 mm)	16
2-in. (50 mm)	16
3-in. (75 mm)	10
4-in. (100 mm)	10

(1) The final rating depends on the clamp and gasket.

**Plate design**

Certain models of flanged alloy and PTFE covered probes have a tank connection design with a protective flange plate of the same material as the probe and with a backing flange in 316L/EN 1.4404. The protective flange plate prevents the backing flange from being exposed to the tank atmosphere.

**Figure 17: Protective Plate**

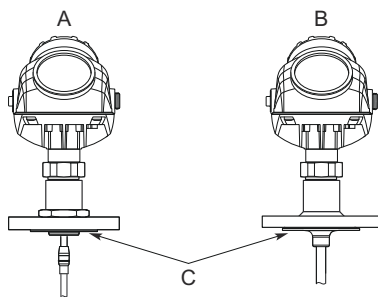

- A. Alloy probe and protective plate
- B. PTFE covered probe and protective plate
- C. Protective plate

Flange rating according to SST backing flange ASME B16.5 Table 2-2.3, EN 1092-1 material group 13E0, and JIS B2220 material group 2.3.

PTFE protective plate:

- Standard: Max. 302 °F/232 psig (150 °C/16 Bar)

Alloy C-276 protective plate:

- Standard: Max. 302 °F/580 psig (150 °C/40 Bar). Flange plate design is available up to Class 300/PN 40
- HP: Max. temp. 250 °C. Flange plate design is available up to Class 600/PN 63
- HTHP: Max. temp. 400 °C. Flange plate design is available up to Class 600/PN 63

Alloy 400 protective plate:

- Standard: Max. 302 °F/580 psig (150 °C/40 Bar). Flange plate design is available up to Class 300/PN 40

**Conditions used for flange strength calculations**

See [Table 15](#) to [Table 18](#) for the conditions used for flange strength calculations.

**Table 15: 316/316L Flanges**

Standard	Bolting material	Gasket		Flange material	Hub material
		Standard/HP/HTHP/C	HP/HTHP/C		
ASME	Stainless steel SA193 B8M Cl.2	Soft (1a) with min. thickness 1.6 mm	Spiral wound gasket with nonmetallic filler (1b)	Stainless steel A182 Gr. F316 and EN 10222-5-1.4404	Stainless steel SA479M 316, and EN 10272-1.4404
EN, JIS	EN 1515-1/-2 group 13E0, A4-70	Soft (EN 1514-1) with min. thickness 1.6 mm	Spiral wound gasket with nonmetallic filler (EN 1514-2)		

**Table 16: Process Connection with Plate Design**

Standard	Bolting material	Gasket		Flange material	Hub material
		Standard/HP/HTHP/C	HP/HTHP/C		
ASME	Stainless steel SA193 B8M Cl.2	Soft (1a) with min. thickness 1.6 mm	Spiral wound gasket with nonmetallic filler (1b)	Stainless steel A182 Gr. F316L/F316 and EN 10222-5-1.4404	SB574 Gr. N10276 or SB164 Gr. N04400
EN, JIS	EN 1515-1/-2 group 13E0, A4-70	Soft (EN 1514-1) with min. thickness 1.6 mm	Spiral wound gasket with nonmetallic filler (EN 1514-2)		

**Table 17: Alloy C-276 Flanges**

Standard	Bolting material	Gasket		Flange material	Hub material
		Standard/HP/HTHP	HP/HTHP		
ASME	UNS N10276	Soft (1a) with min. thickness 1.6 mm	Spiral wound gasket with nonmetallic filler (1b)	SB462 Gr. N10276 (solution annealed condition) or SB575 Gr. N10276 (solution annealed condition)	SB574 Gr. N10276
EN		Soft (EN 1514-1) with min. thickness 1.6 mm	Spiral wound gasket with nonmetallic filler (EN 1514-2)		

Table 18: Duplex 2205 Flanges

Standard	Bolting material	Gasket		Flange material	Hub material
		Standard/HTHP	HP/HTHP		
ASME	A193 B7 or A320 L7	Soft (1a) with min. thickness 1.6 mm	Spiral wound gasket with nonmetallic filler (1b)	Duplex stainless steel SA/A182 F51 and EN10222-5-1.4462 or SA/A240 Gr. S31803 and EN10028-7-1.4462	Stainless steel SA479M S31803 and EN 10272-1.4462
EN	Bumax® 88	Soft (EN 1514-1) with min. thickness 1.6 mm	Spiral wound gasket with nonmetallic filler (EN 1514-2)		

**Interface measurements**

The Rosemount 5302 is a good choice for measuring the interface of oil and water, or other liquids with significant dielectric differences.

It is also possible to measure interface with a Rosemount 5301 in applications where the probe is fully submerged in the liquid, using the submerged probe mode.

Rosemount 5302 with the large coaxial probe provides the ability to continuously keep track of both level and interface level in fully submerged applications. The product level and interface level mode must be selected.

Figure 18: Interface Level Measurement

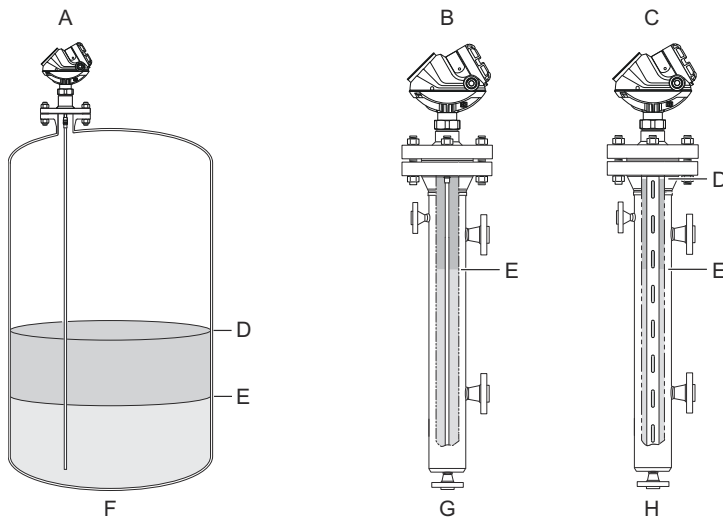

- A. Rosemount 5302
- B. Rosemount 5301
- C. Rosemount 5302 with large coaxial probe
- D. Product level
- E. Interface level
- F. Product level and interface level
- G. Interface level with submerged probe
- H. Product level and interface level with submerged probe

If interface is to be measured, follow these criteria:

- The dielectric constant of the upper product should be known and should not vary. The Rosemount Radar Master software has a built-in dielectric constant calculator to help the user estimate the upper product dielectric constant.

- The dielectric constant of the upper product must have a lower dielectric constant than the lower product to have a distinct reflection.
- The difference between the dielectric constants for the two products must be larger than 6.
- The maximum dielectric constant for the upper product is 7 for the single lead probes, 10 for the coaxial probes, and 8 for the twin lead probes.

**Table 19: Minimum Detectable Upper Product Thickness**

Probe type	Minimum Detectable Upper Product Thickness
Large coaxial	1 in. (2.5 cm) <sup>(1)</sup>
Single lead	2.4 in. (6 cm)
Twin lead	5.1 in. (13 cm)
Coaxial (standard/HP/C)	2.8 in. (7 cm)
Coaxial (HTHP)	8 in. (20 cm)

(1) Depending on application characteristics such as the upper product dielectric constant.

Sometimes there is an emulsion layer (mix of the products) between the two products which can affect interface measurements. For guidelines on emulsion situations, consult your local Emerson representative.

For additional information, see the Guided Wave Radar Interface Measurement [Technical Note](#).

**Related information**

[Interface measuring range](#)

**High pressure steam applications**

**Considerations**

Saturated steam under high pressure can influence radar level transmitter measurements. Rosemount 5301 with Dynamic Vapor Compensation will automatically compensate for this and maintain the level accuracy.

- Probe type 3V (for 3- to 4-in. chambers) or 4U (for 2-in. chambers) must be used.
- Mount in a 2-, 3-, or 4-in. bypass chamber with flanges appropriately sized for the pressure and temperature of the application.
- Dynamic Vapor Compensation requires a minimum distance X from the flange to the surface level in order to measure the change in the vapor dielectric constant. If the level rises within this area, the unit switches over to static compensation, using the last known vapor dielectric constant.

**Table 20: Minimum Distance X**

Reference reflector type		Minimum distance X
Length	Option code	
Short, 14 in. (350 mm)	R1	22 in. (560 mm)
Long, 20 in. (500 mm)	R2	28 in. (710 mm)

Figure 19: Minimum Distance X and Minimum Measuring Span

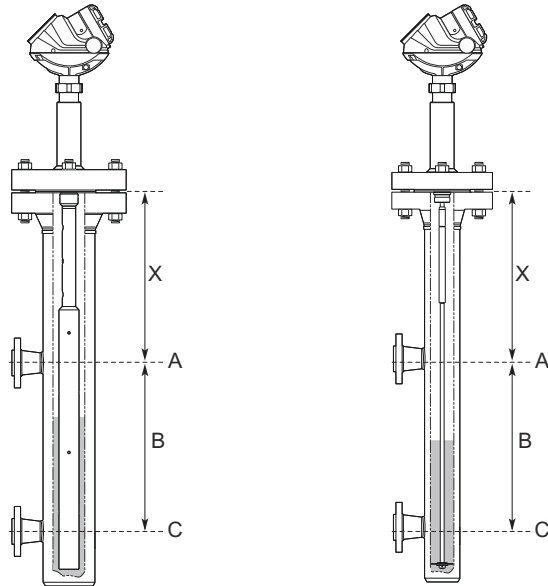

- A. Level: 100%
- B. Minimum measuring span: 12 in. (300 mm)
- C. Level: 0%

- Always ensure there are no disturbances from inlets etc. close to the reference reflector end when using probe type 4U.

#### Select reference reflector

- The long reflector, 20 in. (500 mm), has the best accuracy and is recommended for all chambers where the dimensions of the chamber allow for it.
- If the distance from the flange to the upper inlet is less than 28 in. (710 mm), the short reflector should be chosen. This distance is a minimum when dynamic compensation is required within the whole measuring range from the lower to the upper inlet. If this is not required, the long reflector can be used and dynamic compensation is possible up to 28 in. (710 mm) from the flange.

For more information, refer to the High Pressure Steam Applications [Technical Note](#).

## Physical specifications

### Material selection

Emerson provides a variety of Rosemount products with various product options and configurations including materials of construction that can be expected to perform well in a wide range of applications. The Rosemount product information presented is intended as a guide for the purchaser to make an appropriate selection for the application. It is the purchaser's sole responsibility to make a careful analysis of all process parameters (such as all chemical components, temperature, pressure, flow rate, abrasives, contaminants, etc.), when specifying product, materials, options, and components for the particular application. Emerson is not in a position to evaluate or guarantee the compatibility of the process fluid or other process parameters with the product, options, configuration or materials of construction selected.

### Engineered solutions

When standard model codes are not sufficient to fulfill requirements, please consult the factory to explore possible Engineered Solutions. This is typically, but not exclusively, related to the choice of wetted materials or the design of a process connection. These Engineered Solutions are part of the expanded offerings and may be subject to additional delivery lead time. For ordering, factory will supply a special R-labeled numeric option code that should be added at the end of the standard model string.



## Housing and enclosure

### Type

- Dual compartment (terminal compartment and the electronics are completely separated).
- Two entries for conduit or cable connections.
- The transmitter housing is separable from probe assembly.
- The transmitter housing can be rotated in any direction.

### Electrical connection

½ - 14 NPT for cable glands or conduit entries.

Optional: M20 x 1.5 conduit / cable adapter, M12 4-pin male eurofast® connector or A size Mini 4-pin male minifast® connector.

Recommended output cabling is twisted shielded pairs, 24-12 AWG.

### Housing material

Polyurethane-covered Aluminum, or Stainless Steel Grade CF8M (ASTM A743)

### Ingress protection

NEMA® 4X, IP 66, IP67

### Factory sealed

Yes

### Weight

- Aluminum transmitter head: 4.4 lb (2 kg)
- SST transmitter head: 10.8 lb (4.9 kg)

## Remote housing mounting

Kit that includes a flexible armored extension cable and a bracket for wall or pipe mounting. See [Figure 48](#) for the dimensions.

### Figure 20: Remote Housing Mounting

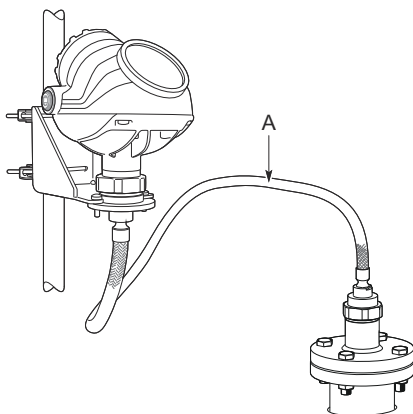

A. Remote Housing Mounting Cable: 3, 6, or 9 ft (1, 2, or 3 m)

## Tank connection

The tank connection consists of a tank seal, a flange, Tri-Clamp®, or NPT or BSPP (G) threads.

### Flange dimensions

Follows ASME B16.5, JIS B2220, and EN 1092-1 standards for blind flanges. For Proprietary Fisher™ and Masoneilan™ flanges, see [Proprietary flanges](#).

### Vented flanges

Available with Masoneilan and Fisher vented flanges. Vented flanges must be ordered as accessories with a 1½-in. NPT threaded process connection (code RA); see [Proprietary flanges](#). As an alternative to a vented flange, it is possible to use a flushing connection ring on top of the standard nozzle.

### Pressure Equipment Directive (PED)

Complies with 2014/68/EU article 4.3

### Probes

#### Probe versions

Coaxial, large coaxial, rigid twin and rigid single lead, segmented rigid single lead, flexible twin and flexible single lead. Probes can be ordered in different materials and options for extreme temperatures and pressure.

For guidelines on which probe to select depending on application, see the Guided Wave Radar Application Guidelines [Technical Note](#).

#### Total probe length

This is defined from the Upper Reference Point to the end of the probe (weight included, if applicable).

**Figure 21: Total Probe Length**

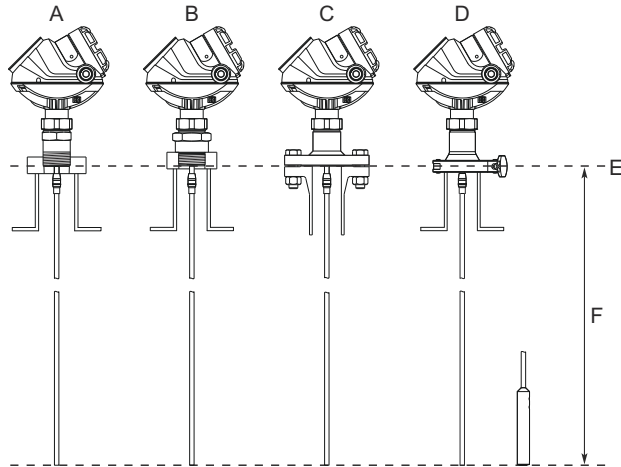

- A. NPT
- B. BSPP (G)
- C. Flange
- D. Tri-Clamp®
- E. Upper reference point
- F. Total probe length

Select the probe length according to the required measuring range (the probe must be hung and fully extended through the entire distance where level readings are desired).

#### Cut-to-fit probes

All probes can be cut in field, except for the HTHP coaxial probe and the PTFE covered probe.

However, there are some restrictions for the standard and HP/C coaxial probes: Probes over 4.1 ft. (1.25 m) can be cut up to 2 ft. (0.6 m). Shorter probes can be cut to the minimum length of 1.3 ft. (0.4 m).

Flexible single lead probes can be cut to the minimum length of 3.3 ft. (1.0 m).

#### Minimum and maximum probe length

Probe type	Probe length
Flexible single lead	3.3 to 164 ft. (1 to 50 m)
Rigid single lead (0.3 in./8 mm)	1.3 to 9.8 ft. (0.4 to 3 m)
Rigid single lead (0.5 in./13 mm)	1.3 to 19.7 ft. (0.4 to 6 m)
Segmented rigid single lead	1.3 to 32.8 ft. (0.4 to 10 m)
Flexible twin lead	3.3 to 164 ft. (1 to 50 m)
Rigid twin lead	1.3 to 9.8 ft. (0.4 to 3 m)
Coaxial	1.3 to 19.7 ft. (0.4 to 6 m)
Large coaxial	1.0 to 19.7 ft. (0.3 to 6 m)

#### Probe angle

0 to 90 degrees from vertical axis

#### Note

Models with QT option code should not be installed in angled probe installations.

#### Tensile strength

- 0.16 in. (4 mm) Flexible single lead SST: 2698 lb (12 kN)
- 0.16 in. (4 mm) Flexible single lead Alloy C-276: 1798 lb (8 kN)
- 0.16 in. (4 mm) Flexible single lead Alloy 400: 1124 lb (5 kN)
- 0.16 in. (4 mm) Flexible single lead Duplex 2205: 1349 lb (6 kN)
- 0.24 in. (6 mm) Flexible single lead SST: 6519 lb (29 kN)
- Flexible twin lead SST: 2023 lb (9 kN)

#### Collapse load

- 0.16 in. (4 mm) Flexible single lead SST: 3597 lb (16 kN)
- 0.16 in. (4 mm) Flexible single lead Alloy C-276: 2023 lb (9 kN)
- 0.16 in. (4 mm) Flexible single lead Alloy 400: 1349 lb (6 kN)
- 0.16 in. (4 mm) Flexible single lead Duplex 2205: 1574 lb (7 kN)
- 0.24 in. (6 mm) Flexible Single Lead SST: 7868 lb (35 kN)

#### Sideway capacity

- Rigid single lead/Segmented rigid single lead: 4.4 ft. lbf, 0.44 lb at 9.8 ft. (6 Nm, 0.2 kg at 3 m)
- Rigid twin lead: 2.2 ft. lbf, 0.22 lb at 9.8 ft. (3 Nm, 0.1 kg at 3 m)
- Coaxial/Large coaxial: 73.7 ft. lbf, 3.7 lb at 19.7 ft. (100 Nm, 1.67 kg at 6 m)

## Material exposed to tank atmosphere

**Table 21: Standard Probe (Operating Temperature and Pressure Code S)**

Material of construction code	Material exposed to tank atmosphere
1 (probe types 6A and 6B)	316L (EN 1.4404), 316 <sup>(1)</sup> , Duplex 2507 (UNS S32750/EN 1.4410), PTFE, PFA, silicone grease, and O-ring materials
1 (all other probe types)	316L (EN 1.4404), 316 <sup>(1)</sup> , PTFE, PFA, silicone grease, and O-ring materials
2 and H	Alloy C-276 (UNS N10276), PTFE, PFA, silicone grease, and O-ring materials
3	Alloy 400 (UNS N04400), Alloy K500, PTFE, PFA, silicone grease, and O-ring materials
7	PTFE (1 mm PTFE cover)
8	PTFE, 316/316L (EN 1.4404), silicone grease, and O-ring materials
D	Duplex 2205 (UNS S31803/EN 1.4462), Duplex 2507 (UNS S32750/EN 1.4410), PTFE, PFA, silicone grease, and O-ring materials

(1) For flexible single/twin lead probes only.

**Table 22: HTHP Probe (Operating Temperature and Pressure Code H)**

Material of construction code	Material exposed to tank atmosphere
1	316L (EN 1.4404), 316 <sup>(1)</sup> , Ceramic (Al <sub>2</sub> O <sub>3</sub> ), Graphite, and Alloy 625
2 and H	Alloy C-276 (UNS N10276), Ceramic (Al <sub>2</sub> O <sub>3</sub> ), Graphite, and Alloy 625
D	Duplex 2205 (UNS S31803/EN 1.4462), Ceramic (Al <sub>2</sub> O <sub>3</sub> ), Graphite, and Alloy 625

(1) For flexible single/twin lead probes only.

**Table 23: HP Probe (Operating Temperature and Pressure code P)**

Material of construction code	Material exposed to tank atmosphere
1	316L (EN 1.4404), 316 <sup>(1)</sup> , Ceramic (Al <sub>2</sub> O <sub>3</sub> ), Graphite, PFA, PTFE, and Alloy 625
2 and H	Alloy C-276 (UNS N10276), Ceramic (Al <sub>2</sub> O <sub>3</sub> ), Graphite, PFA, PTFE, and Alloy 625
D	Duplex 2205 (UNS S31803/EN 1.4462), Ceramic (Al <sub>2</sub> O <sub>3</sub> ), Graphite, PFA, PTFE, and Alloy 625

(1) For flexible single/twin lead probes only.

**Table 24: Cryogenic Probe (Operating Temperature and Pressure code C)**

Material of construction code	Material exposed to tank atmosphere
1	316L (EN 1.4404), 316 <sup>(1)</sup> , Ceramic (Al <sub>2</sub> O <sub>3</sub> ), Graphite, PFA, PTFE, and Alloy 625

(1) For flexible single/twin lead probes only.

## Weight

**Table 25: Flange and Probes**

Item	Weight
Flange	Depends on flange size
Flexible single lead probe	0.05 lb/ft. (0.08 kg/m)
Rigid single lead probe (0.3-in./8 mm)	0.27 lb/ft. (0.4 kg/m)
Rigid single lead probe (0.5-in./13 mm)	0.71 lb/ft. (1.06 kg/m)
Segmented rigid single lead probe	0.71 lb/ft. (1.06 kg/m)
Flexible twin lead probe	0.09 lb/ft. (0.14 kg/m)
Rigid twin lead probe	0.40 lb/ft. (0.6 kg/m)
Coaxial probe	0.67 lb/ft. (1 kg/m)
Large coaxial probe	1.48 lb/ft. (2.2 kg/m)

**Table 26: End Weight**

Item	Weight
Standard weight for flexible single lead probe (0.16-in./4 mm)	0.88 lb (0.40 kg)
Short weight (W2) for flexible single lead probe (0.16-in./4 mm)	0.88 lb (0.40 kg)
Heavy weight (W3) for flexible single lead probe (0.16-in./4 mm)	2.43 lb (1.10 kg)
Weight for flexible single lead probe (0.24-in./6 mm)	1.2 lb (0.55 kg)
Weight for PTFE covered flexible single lead	2.2 lb (1 kg)
Weight for twin lead probe	1.3 lb (0.60 kg)

### End weight options

A short weight is available for the single flexible probe. It is used for measuring close to the probe end and shall be used where the measuring range must be maximized. The height is 2 in. (50 mm) and the diameter is 1.5 in. (37.5 mm). The option code is W2.

### Installation and mounting considerations

#### Free space requirement

If the probe is mounted close to a wall, nozzle or other tank obstruction, noise might appear in the level signal. Therefore the following minimum clearance, according to [Table 27](#), must be maintained.

Figure 22: Free Space Requirement

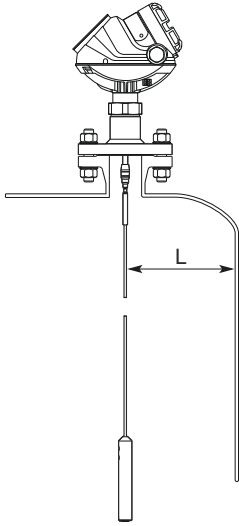

L. Clearance to tank wall

Table 27: Recommended Minimum Free Space to Tank Wall or Other Objects in the Tank

Probe type	Condition	Minimum clearance (L)
Rigid single lead/Segmented rigid single lead <sup>(1)</sup>	Smooth metal tank wall	4 in. (100 mm)
	Disturbing objects such as pipes and beams Plastic, concrete or rugged metal tank wall	16 in. (400 mm) 20 in. (500 mm) <sup>(2)</sup>
Flexible single	Smooth metal tank wall	4 in. (100 mm)
	Disturbing objects such as pipes and beams Plastic, concrete or rugged metal tank wall	20 in. (500 mm)
Coaxial/Large coaxial <sup>(1)</sup>	N/A	0 in. (0 mm)
Rigid twin lead	N/A	4 in. (100 mm)
Flexible twin	N/A	4 in. (100 mm)

(1) Minimum clearance from tank bottom for the coaxial, large coaxial and rigid single probes is 0.2 in. (5 mm).

(2) Applies to measurements with DC 1.4 or lower.

**Flange connection on nozzles**

**Figure 23: Mounting in Nozzles**

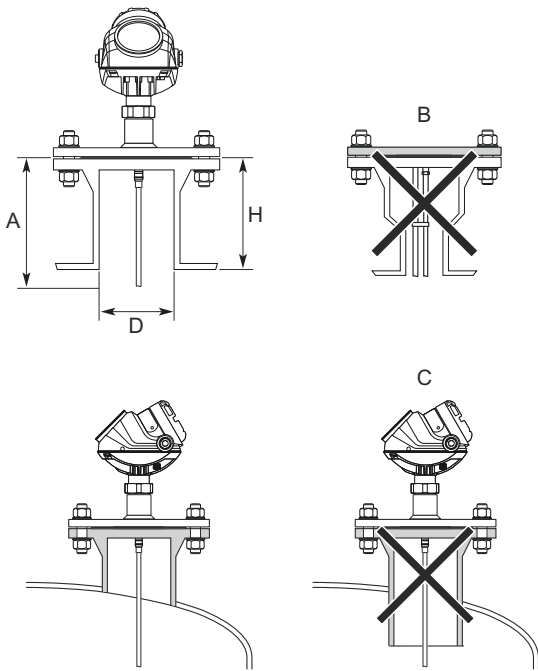

- A. Hold Off Distance/UNZ
- B. Avoid nozzles with reducer (unless using coaxial probe).
- C. Confirm the nozzle does not extend into the tank.

The transmitter can be mounted in nozzles by using an appropriate flange. It is recommended that the nozzle size is within the dimensions given in [Table 28](#).

**Table 28: Nozzle Considerations**

	Single (rigid/segmented/flexible)	Coaxial/Large coaxial	Twin (rigid/flexible)
Recommended nozzle diameter (D)	6 in. (150 mm)	> probe diameter	4 in. (100 mm)
Minimum nozzle diameter (D) <sup>(1)</sup>	2 in. (50 mm)	> probe diameter	2 in. (50 mm)
Recommended nozzle height (H) <sup>(2)</sup>	4 in. (100 mm) + nozzle diameter <sup>(3)</sup>	N/A	4 in. (100 mm) + nozzle diameter

- (1) The Trim Near Zone (TNZ) function may be necessary or an Hold Off Distance/Upper Null Zone (UNZ) setup may be required to mask the nozzle.
- (2) Longer nozzles may be used in certain applications. Consult your local Emerson representative for details.
- (3) For nozzles taller than 4 in. (100 mm), the long stud version is recommended (option code LS) to prevent the flexible portion from touching the edge of the nozzle.

A long stud - 9.8 in. (250 mm) - is recommended for single flexible probes in a tall nozzle.

**Figure 24: A Single Flexible Probe with a Long Stud**

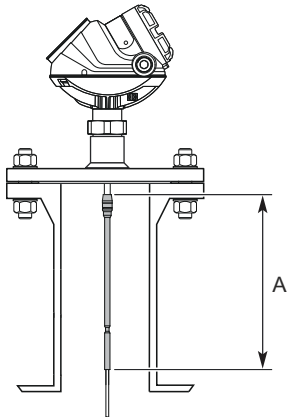

A. Long Stud (9.8 in./250 mm)

**Installation in non-metallic tanks and open-air applications**

Avoid major sources of electrical disturbance in proximity of the installation (e.g. electrical motors, stirrers, servo mechanisms).

**Figure 25: Avoid Electromagnetic Disturbances**

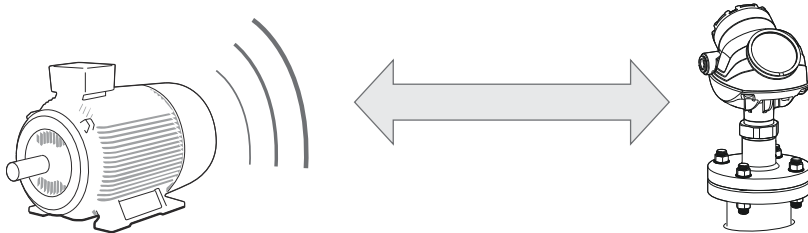

For clean liquids, use a coaxial probe to reduce effect of potential electrical disturbances.

**Figure 26: Coaxial Probe in an Open-Air Application**

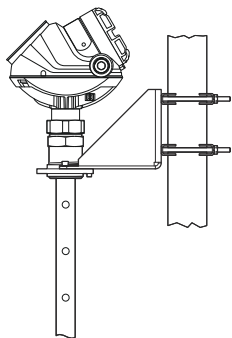

For optimal single lead probe performance in non-metallic tanks, the probe must be mounted with a metal flange, or screwed in to a metal sheet ( $d > 14$  in./350 mm) if a threaded version is used.



**Figure 27: Mounting in Non-Metallic Tanks**

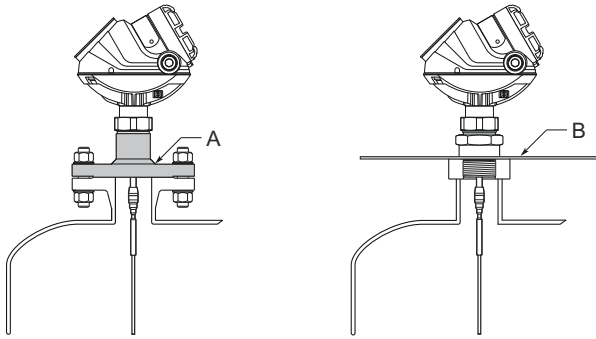

- A. Metal flange
- B. Metal sheet ( $d > 14 \text{ in./}350 \text{ mm}$ )

**Minimum distance between two single probes**

When installing multiple Rosemount 5300 Level Transmitters with single probes in the same tank, ensure to place the devices at proper distance from each other to avoid the risk of interference caused by cross-talk. Table 29 provides recommended minimum distance between two probes. A coaxial probe or a probe installed in a still pipe will not cause any cross-talk.

**Table 29: Minimum Distance between Single Probes**

Product	Minimum distance between probes
Oil (DC = 2.1)	5.2 ft. (1.6 m)
Water (DC = 80)	3.3 ft. (1.0 m)

**Other mechanical considerations**

To get best possible performance, the following must be considered before installing the transmitter:

- Inlets should be kept at a distance in order to avoid product filling on the probe
- Avoid physical contact between probes and agitators, as well as applications with strong fluid movement unless the probe is anchored
- Probe tie-down is recommended if the probe can move to within 1 ft. (30 cm) of any object during operations
- In order to stabilize the probe for side forces, it is possible to fix or guide the probe to the tank bottom

**Figure 28: Stabilize the Probe for Side Forces**

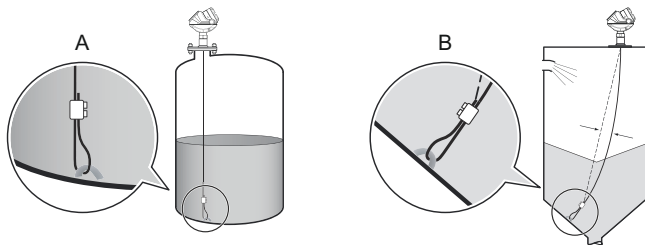

- A. Flexible single lead probe with chuck installed in liquids and in solids.
- B. For solids, it is recommended that the probe should be slack to prevent high tensile loads.

See the Rosemount 5300 Reference Manual for more mechanical installation information.

## Installation in still pipe/chamber

### General chamber considerations

Dimensioning the chamber/pipe correctly and selecting the appropriate probe is key to the success in these applications. When selecting a smaller chamber/pipe diameter, such as 2-in., a flexible probe is not suitable due to the chance of it coming into contact with the walls. Also, relatively large side inlets may interfere with the signal.

When gas lift and/or turbulence may occur (e.g. boiling hydrocarbons), a 3- or 4-in. chamber/pipe diameter is recommended for maximum measurement reliability. This is especially true in high pressure and high temperature installations.

**Table 30: Recommended and Minimum Chamber/Still Pipe Diameters for Different Probes**

Probe type	Recommended diameter	Minimum diameter
Rigid single/segmented rigid single	3 or 4 in. (75 or 100 mm)	2 in. (50 mm)
Flexible single	4 in. (100 mm)	Consult your local Emerson representative
Rigid twin <sup>(1)</sup>	3 or 4 in. (75 or 100 mm)	2 in. (50 mm)
Flexible twin <sup>(1)</sup>	4 in. (100 mm)	Consult your local Emerson representative
Coaxial	3 or 4 in. (75 or 100 mm)	1.5 in. (37.5 mm)
Large coaxial	3 or 4 in. (75 or 100 mm)	2 in. (50 mm) <sup>(2)</sup>

(1) The center rod must be placed more than 0.6 in. (15 mm) away from the pipe wall.

(2) Applicable to pipe schedule up to 40s,40. For higher pipe schedule consult your local Emerson representative.

### Note

Metal pipes are preferred, especially in applications with low dielectric constant, to avoid disturbances from objects near the pipe.

## Related information

[Dimensional drawings](#)

### Rosemount chamber

A Rosemount chamber allows external mounting of process level instrumentation. It supports a variety of process connections, and optional drain and vent connections. The Rosemount chambers are designed to the ASME B31.3 standard, and are Pressure Equipment Directive (PED) compliant. Use option code XC to order together with the Rosemount 5300 Series Transmitters.

Use a centering disc the same diameter as the chamber if the probe length >3.3 ft. (1 m). See [Table 33](#) for which disc to use.

### Existing chamber

A Rosemount 5300 Level Transmitter is the perfect replacement in an existing displacer chamber. Proprietary flanges are offered, enabling use of existing chambers to make installation easy.

**Figure 29: Existing Displacer Chamber**

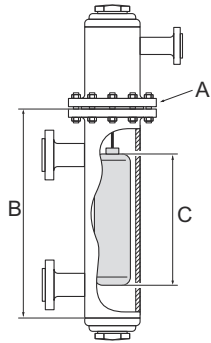

- A. Replace chamber flange
- B. Probe length
- C. Displacer length

Considerations when changing to Rosemount 5300:

- The Rosemount 5300 Level Transmitter flange choice and probe length must be correctly matched to the chamber. Both standard ASME and EN (DIN), as well as proprietary chamber flanges, are available. See [Proprietary flanges](#) to identify the proprietary flanges.
- See [Table 33](#) for guidelines on which disc size to use.
- See [Table 31](#) for guidelines on the required probe length.

**Table 31: Required Probe Length in Chambers**

Chamber manufacturer	Probe length <sup>(1)</sup>
Major torque-tube manufacture (249B, 249C, 249K, 249N, 259B)	Displacer + 9 in. (229 mm)
Masoneilan™ (Torque tube operated), proprietary flange	Displacer + 8 in. (203 mm)
Other - torque tube <sup>(2)</sup>	Displacer + 8 in. (203 mm)
Magnetrol® (spring operated) <sup>(3)</sup>	Displacer + between 7.8 in. (195 mm) to 15 in. (383 mm)
Others - spring operated <sup>(2)</sup>	Displacer + 19.7 in. (500 mm)

(1) If flushing ring is used, add the ring height to the probe length.  
 (2) For other manufacturers, there are small variations. This is an approximate value, actual length should be verified.  
 (3) Lengths vary depending on model, SG and rating, and should be verified.

For additional information, see the Replacing Displacers with Guided Wave Radar [Technical Note](#).

**Probe type in chamber considerations**

When installing a Rosemount 5300 in a chamber, the single lead probe is recommended. Other probe types are more susceptible to build-up and are not recommended.<sup>(10)</sup> An exception is applications with liquefied gas > 40 bar, where a coaxial probe should be used.

The probe must not touch the chamber wall, should extend the full height of the chamber, but not touch the bottom of the chamber.

The probe length determines if a single rigid or single flexible probe should be used:

- Less than 19.7 ft. (6.0 m): Rigid single probe is recommended. Use a centering disc for probe > 3.3 ft. (1 m). When mounting space is limited, use a flexible single probe with a weight and centering disc.
- More than 19.7 ft. (6.0 m): Use flexible single probe with a weight and centering disc. <sup>(11)</sup>

(10) The single probe creates a virtual coaxial probe with the chamber as the outer tube. The extra gain provided by the twin and coaxial probes is not necessary; the electronics in the Rosemount 5300 Level Transmitter is very sensitive and is not a limiting factor.

PTFE covered probes are not recommended for chamber/pipe installations.

### Centering disc for pipe installations

To prevent the probe from contacting the chamber or pipe wall, centering discs are available for flexible single, rigid single, and flexible twin lead probes. The disc is attached to the end of the probe. Discs are made of stainless steel, Alloy C-276, Duplex 2205, or PTFE. The centering disc in PTFE is not available for HTHP probes.

For the segmented rigid single lead probe, up to five PTFE centering discs can be mounted along the probe, but keep a minimum distance of two segments between the discs. Additionally, a disc in SST or PTFE (part number 03300-1655-xxxx) can be attached to the end of the probe.

When mounting a centering disc, it is important that it fits correctly in the chamber/pipe. See Figure 30 for Dimension D. Table 33 shows which centering disc diameter to choose for a particular pipe. Table 34 shows which centering disc diameter to choose for a Rosemount chamber.

Figure 30: Dimension D for Centering Discs

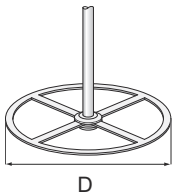

Table 32: Centering Discs Dimensions

Disc size	Actual disc diameter (D)
2-in.	1.8 in. (45 mm)
3-in.	2.7 in. (68 mm)
4-in.	3.6 in. (92 mm)
6-in.	5.55 in. (141 mm)
8-in.	7.40 in. (188 mm)

Table 33: Centering Disc Size Recommendation for Different Pipe Schedules

Pipe size	Pipe schedule			
	5s, 5 and 10s, 10	40s, 40 and 80s, 80	120	160
2-in.	2-in.	2-in.	N/A <sup>(1)</sup>	N/A <sup>(2)</sup>
3-in.	3-in.	3-in.	N/A <sup>(1)</sup>	2-in.
4-in.	4-in.	4-in.	4-in.	3-in.
5-in.	4-in.	4-in.	4-in.	4-in.
6-in.	6-in.	6-in.	4-in.	4-in.
7-in.	N/A <sup>(1)</sup>	6-in.	N/A <sup>(1)</sup>	N/A <sup>(1)</sup>
8-in.	8-in.	8-in.	6-in.	6-in.

(1) Schedule is not available for pipe size.

(2) No centering disc is available.

(11) The Blind Zones and the height of the weight limit the use of single flexible probes shorter than 3 ft. (1 m). If using the flexible probe, the short weight is recommended.

**Table 34: Centering Disc Size Recommendations for Rosemount Chambers**

Chamber size	Chamber rating	Centering disc
3-in.	Up to Class 600/PN 100	3-in.
	Class 900, 1500/PN160, 250	2-in.
3-in. T-piece	Up to Class 600/PN 100	2-in.
4-in.	Up to Class 600/PN 100	4-in.
	Class 900, 1500/PN160, 250	3-in.

## Product certifications

Rev 10.15

### European directive information

A copy of the EU Declaration of Conformity can be found at the end of the Quick Start Guide. The most recent revision of the EU Declaration of Conformity can be found at [Emerson.com/Rosemount](http://Emerson.com/Rosemount).

### Safety Instrumented Systems (SIS)

SIL 3 Capable: IEC 61508 certified for use in safety instrumented systems up to SIL 3 (Minimum requirement of single use (1oo1) for SIL 2 and redundant use (1oo2) for SIL 3).

### Ordinary location certification

As standard, the transmitter has been examined and tested to determine that the design meets the basic electrical, mechanical, and fire protection requirements by a nationally recognized test laboratory (NRTL) as accredited by the Federal Occupational Safety and Health Administration (OSHA).

### Installing equipment in North America

The US National Electrical Code® (NEC) and the Canadian Electrical Code (CEC) permit the use of Division marked equipment in Zones and Zone marked equipment in Divisions. The markings must be suitable for the area classification, gas, and temperature class. This information is clearly defined in the respective codes.

## USA

### E5 Explosionproof (XP), Dust-Ignitionproof (DIP)

<b>Certificate</b>	FM16US0444X
<b>Standards</b>	FM Class 3600 – 2018; FM Class 3610 – 2010; FM Class 3611 – 2004; FM Class 3615 – 2006; FM Class 3810 – 2005; ANSI/ISA 60079-0 – 2013; ANSI/ISA 60079-11 – 2012; ANSI/NEMA® 250 – 2003;
<b>Markings</b>	XP CLI, DIV 1, GP B, C, D; DIP CLII/III, DIV 1, GP E, F, G; T4; -50 °C ≤ Ta ≤ 60 °C (FIELD BUS) / 70 °C (HART); Type 4X

#### Special Conditions for Safe Use (X):

1. WARNING – Potential Electrostatic Charging Hazard – The enclosure contains non-metallic material. To prevent the risk for electrostatic sparking the plastic surface should only be cleaned with a damp cloth.
2. WARNING – The apparatus enclosure contains aluminum and is considered to constitute a potential risk of ignition by impact or friction. Care must be taken into account during installation and use to prevent impact or friction.

### I5 Intrinsic Safety (IS), Nonincendive (NI)

<b>Certificate</b>	FM16US0444X
--------------------	-------------

- Standards** FM Class 3600 – 2018; FM Class 3610 – 2010; FM Class 3611 – 2004; FM Class 3615 – 2006; FM Class 3810 – 2005; ANSI/ISA 60079-0 – 2013; ANSI/ISA 60079-11 – 2012; ANSI/NEMA 250 – 2003;
- Markings** IS CL I, II, III, DIV 1, GP A, B, C, D, E, F, G in accordance with control drawing 9240030-936; IS (Entity) CL I, Zone 0, AEx ia IIC T4 in accordance with control drawing 9240030-936, NI CL I, II, III DIV 2, GP A, B, C, D, F, G; T4; -50 °C ≤ Ta ≤ 60 °C (FIELDBUS) / 70 °C (HART); Type 4X

**Special Conditions for Safe Use (X):**

1. WARNING – Potential Electrostatic Charging Hazard – The enclosure contains non-metallic material. To prevent the risk for electrostatic sparking the plastic surface should only be cleaned with a damp cloth.
2. WARNING – The apparatus enclosure contains aluminum and is considered to constitute a potential risk of ignition by impact or friction. Care must be taken into account during installation and use to prevent impact or friction.

	Ui	Ii	Pi	Ci	Li
Entity parameters HART	30 V	130 mA	1 W	7.26 nF	0
Entity parameters Fieldbus	30 V	300 mA	1.3 W	0	0

**IE FISCO**

- Certificate** FM16US0444X
- Standards** FM Class 3600 – 2018; FM Class 3610 – 2010; FM Class 3611 – 2004; FM Class 3615 – 2006; FM Class 3810 – 2005; ANSI/ISA 60079-0 – 2013; ANSI/ISA 60079-11 – 2012; ANSI/NEMA 250 – 2003;
- Markings** IS CL I, II, III, DIV 1, GP A, B, C, D, E, F, G; T4; in accordance with control drawing 9240030-936; IS CL I, Zone 0 AEx ia IIC T4 in accordance with control drawing 9240030-936; -50 °C ≤ Ta ≤ 60 °C; Type 4X

**Special Conditions for Safe Use (X):**

1. WARNING – Potential Electrostatic Charging Hazard – The enclosure contains non-metallic material. To prevent the risk for electrostatic sparking the plastic surface should only be cleaned with a damp cloth.
2. WARNING – The apparatus enclosure contains aluminum and is considered to constitute a potential risk of ignition by impact or friction. Care must be taken into account during installation and use to prevent impact or friction.

	Ui	Ii	Pi	Ci	Li
FISCO parameters	17.5 V	380 mA	5.32 W	0	0

**Canada**

**E6 Explosionproof, Dust-Ignitionproof**

- Certificate** 1514653
- Standards** CSA C22.2 No.0-M91, CSA C22.2 No.25-1966, CSA C22.2 No.30-M1986, CSA C22.2 No.94-M91, CSA C22.2 No.142-M1987, CSA C22.2 157-92, CAN/CSA C22.2 No. 60529:05, ANSI/ISA 12.27.01-2003
- Markings** Explosionproof CL I, DIV 1, GP B, C, D; Dust-Ignitionproof CL II, DIV 1 and 2, GP E, F, G and coal dust, CL III, DIV 1, Type 4X/IP66/IP67 Maximum Ambient Temperature +60 °C for Fieldbus and FISCO and +70 °C for HART

**I6 Intrinsically Safe and Non-Incendive Systems**

- Certificate** 1514653

**Standards** CSA C22.2 No.0-M91, CSA C22.2 No.25-1966, CSA C22.2 No.30-M1986, CSA C22.2 No.94-M91, CSA C22.2 No.142-M1987, CSA C22.2 157-92, CAN/CSA C22.2 No. 60529:05, ANSI/ISA 12.27.01-2003

**Markings** CL I, DIV 1, GP A, B, C, D, T4 see installation drawing 9240030-937; Non-Incendive Class III, DIV 1, Haz-loc CL I DIV 2, GP A, B, C, D, Maximum Ambient Temperature +60 °C for Fieldbus and FISCO and +70 °C for HART, T4, Type 4X/IP66/IP67, Maximum Working Pressure 5000 psi, Dual Seal.

	Ui	Ii	Pi	Ci	Li
Entity parameters HART	30 V	130 mA	1 W	7.26 nF	0
Entity parameters Fieldbus	30 V	300 mA	1.3 W	0	0

## IF FISCO

**Certificate** 1514653

**Standards** CSA C22.2 No.0-M91, CSA C22.2 No.25-1966, CSA C22.2 No.30-M1986, CSA C22.2 No.94-M91, CSA C22.2 No.142-M1987, CSA C22.2 157-92, CAN/CSA C22.2 No. 60529:05, ANSI/ISA 12.27.01-2003

**Markings** CL I, DIV 1, GP A, B, C, D, T4 see installation drawing 9240030-937; Non-Incendive Class III, DIV 1, Haz-loc CL I DIV 2, GP A, B, C, D, Maximum Ambient Temperature +60 °C, T4, Type 4X/IP66/IP67, Maximum Working Pressure 5000 psi, Dual Seal.



	Ui	Ii	Pi	Ci	Li
FISCO parameters	17.5 V	380 mA	5.32 W	0	0

## Europe

### E1 ATEX Flameproof

**Certificate** Nemko 04ATEX1073X

**Standards** EN 60079-0:2018 / EN 60079-0:2012/A11:2013, EN 60079-1:2014, EN 60079-11:2012, EN 60079-26:2015, EN 60079-31:2014

**Markings**  II 1/2G Ex db ia IIC T4 Ga/Gb, -55 °C ≤ Ta ≤ +60 °C (FIELDBUS) /+70 °C (HART)  
 II 1D Ex ta IIIC T69 °C (FIELDBUS) /T79 °C (HART) Da -40 °C ≤ Ta ≤ +60 °C (FIELDBUS) /+70 °C (HART)  
 Um = 250 V

### Special Conditions for Safe Use (X):

1. Potential ignition hazards by impact or friction need to be considered according to EN 60079-0:2018 clause 8.3 (for EPL Ga and EPL Gb), and clause 8.4 (for EPL Da and EPL Db), when the transmitter enclosure and antennas exposed to the exterior atmosphere of the tank, is made with light metals containing aluminium or titanium. The end user shall determine the suitability with regard to avoid hazards from impact and friction.
2. Parts of the sensor probes, for type 5300, are non-conducting material covering metal surfaces. The area of the non-conducting part exceeds the maximum permissible areas for Group III according to EN 60079-0: 2018 clause 7.4.3 Therefore, when the probe is used in a potentially explosive atmosphere group III, EPL Da, appropriate measures must be taken to prevent electrostatic discharge.
3. The painted transmitter housing is non-conducting and exceeds the maximum permissible areas for Group III according to EN 60079-0: 2018 clause 7.4:3. Therefore, when the probe is used in a potentially dust explosive atmosphere group III, appropriate measures must be taken to prevent electrostatic discharge (i.e. only clean with a damp cloth).
4. 1/2” NPT threads need to be sealed for dust and water ingress protection, IP 66, IP 67 or “Ex t”. EPL Da or Db is required.



### I1 ATEX Intrinsic Safety

- Certificate** Nemko 04ATEX1073X
- Standards** EN 60079-0:2018 / EN 60079-0:2012/A11:2013, EN 60079-1:2014, EN 60079-11:2012, EN 60079-26:2015, EN 60079-31:2014
- Markings**
  - ⊕ II 1G Ex ia IIC T4 Ga, -55 °C ≤ Ta ≤ +60 °C (FIELDBUS) /+70 °C (HART)
  - ⊕ II 1D Ex ia IIIC T69 °C/T79 °C Da, -50 °C ≤ Ta ≤ +60 °C (FIELDBUS) /+70 °C (HART)

#### Special Conditions for Safe Use (X):

1. The intrinsically safe circuits do not withstand the 500V AC test as specified in EN 60079-11:2012 clause 6.3.13.
2. Potential ignition hazards by impact or friction need to be considered according to EN 60079-0:2018 clause 8.3 (for EPL Ga and EPL Gb), and clause 8.4 (for EPL Da and EPL Db), when the transmitter enclosure and antennas exposed to the exterior atmosphere of the tank, is made with light metals containing aluminium or titanium. The end user shall determine the suitability with regard to avoid hazards from impact and friction.
3. Parts of the sensor probes, for type 5300, are non-conducting material covering metal surfaces. The area of the non-conducting part exceeds the maximum permissible areas for Group III according to EN 60079-0: 2018 clause 7.4.3 Therefore, when the antenna is used in a potentially explosive atmosphere group III, EPL Da, appropriate measures must be taken to prevent electrostatic discharge.
4. The painted transmitter housing is non-conducting and exceeds the maximum permissible areas for Group III according to EN 60079-0: 2018 clause 7.4:3. Therefore, when the probe is used in a potentially dust explosive atmosphere group III, appropriate measures must be taken to prevent electrostatic discharge (i.e. only clean with a damp cloth).
5. 1/2” NPT threads need to be sealed for dust and water ingress protection, IP 66, IP 67 or “Ex t”. EPL Da or Db is required.

	Ui	Ii	Pi	Ci	Li
Entity parameters HART	30 V	130 mA	1 W	7.26 nF	0
Entity parameters Fieldbus	30 V	300 mA	1.5 W	4.95 nF	0

### IA ATEX FISCO

- Certificate** Nemko 04ATEX1073X
- Standards** EN 60079-0:2018 / EN 60079-0:2012/A11:2013, EN 60079-1:2014, EN 60079-11:2012, EN 60079-26:2015, EN 60079-31:2014
- Markings**
  - ⊕ II 1G Ex ia IIC T4 Ga (-55 °C ≤ Ta ≤ +60 °C) or
  - ⊕ II 1/2G Ex ia/ib IIC T4 Ga/Gb (-55 °C ≤ Ta ≤ +60 °C)
  - ⊕ II 1D Ex ia IIIC T69 °C Da, (-50 °C ≤ Ta ≤ +60 °C)
  - ⊕ II 1D Ex ia/ib IIIC T69 °C Da/Db, (-50 °C ≤ Ta ≤ +60 °C)

#### Special Conditions for Safe Use (X):

1. The intrinsically safe circuits do not withstand the 500V AC test as specified in EN 60079-11:2012 clause 6.3.13.
2. Potential ignition hazards by impact or friction need to be considered according to EN 60079-0:2018 clause 8.3 (for EPL Ga and EPL Gb), and clause 8.4 (for EPL Da and EPL Db), when the transmitter enclosure and antennas exposed to the exterior atmosphere of the tank, is made with light metals containing aluminium or titanium. The end user shall determine the suitability with regard to avoid hazards from impact and friction.
3. Parts of the sensor probes, for type 5300, are non-conducting material covering metal surfaces. The area of the non-conducting part exceeds the maximum permissible areas for Group III according to EN 60079-0: 2018 clause 7.4.3 Therefore, when the antenna is used in a potentially explosive atmosphere group III, EPL Da, appropriate measures must be taken to prevent electrostatic discharge.

4. The painted transmitter housing is non-conducting and exceeds the maximum permissible areas for Group III according to EN 60079-0: 2018 clause 7.4:3.. Therefore, when the probe is used in a potentially dust explosive atmosphere group III, appropriate measures must be taken to prevent electrostatic discharge (i.e. only clean with a damp cloth).
5. The Ex ia version of model 5300 FISCO device may be supplied by an “Ex ib” FISCO power supply, when the power supply is certified with three separate safety current limiting devices and voltage limitation which meets the requirements for type Ex ia.
6. 1/2” NPT threads need to be sealed for dust and water ingress protection, IP 66, IP 67 or “Ex t”. EPL Da or Db is required.

	Ui	Ii	Pi	Ci	Li
FISCO parameters	17.5 V	380 mA	5.32 W	4.95 nF	<1 μH

### N1 ATEX Type N

- Certificate** Nemko 10ATEX1072X
- Standards** EN 60079-0:2012+A11:2013, EN 60079-11:2012, EN 60079-15:2010, EN 60079-31:2014
- Markings** Ⓢ II 3G Ex nA ic IIC T4 Gc  
 Ⓢ II 3G Ex ic IIC T4 Gc  
 Ⓢ II 3D Ex tc IIIC T69 °C (FIELDBUS) /T79 °C (HART) Dc  
 -50 °C ≤ Ta ≤ +60 °C (FIELDBUS) /+70 °C (HART)

#### Special Conditions for Safe Use (X):

1. The transmitter circuits does not withstand 500V AC dielectric strength test according to EN 60079-11 clause 6.3.13 due to earth connected transient suppressing devices. Appropriate measures have to be considered by installation.

	Ui	Ii	Pi	Ci	Li
Safety parameters HART	42.4 V	23 mA	1 W	7.25 nF	Negligible
Safety parameters Fieldbus	32 V	21 mA	0.7 W	4.95 nF	Negligible

## International

### E7 IECEx Flameproof

- Certificate** IECEx NEM 06.0001X
- Standards** IEC 60079-0:2011, IEC 60079-1:2014-06, IEC 60079-11:2011, IEC 60079-26:2014, IEC 60079-31:2013
- Markings** Ex db ia IIC T4 Ga/Gb  
 -55 °C ≤ Ta ≤ +60 °C (FIELDBUS) /+70 °C (HART)  
 Ex ta IIIC T69 °C (FIELDBUS) /T79 °C (HART) Da  
 -40 °C ≤ Ta ≤ +60 °C (FIELDBUS) /+70 °C (HART)  
 Um=250 VAC, IP66/IP67

#### Special Conditions for Safe Use (X):

1. Potential ignition hazards by impact or friction need to be considered according to IEC 60079-0:2011 clause 8.3 (for EPL Ga and EPL Gb), and clause 8.4 (for EPL Da and EPL Db), when the transmitter enclosure and antennas exposed to the exterior atmosphere of the tank, is made with light metals containing aluminium or titanium. The end user shall determine the suitability with regard to avoid hazards from impact and friction.

2. Parts of the sensor probes for type 5300 are non-conducting material covering metal surfaces and the area of the non-conducting part exceeds the maximum permissible areas for Group III according to IEC 60079-0: 2011 clause 7.4:3. Therefore, when the antenna is used in a potentially explosive atmosphere group III, EPL Da, appropriate measures must be taken to prevent electrostatic discharge.
3. The painted transmitter housing is non-conducting and exceeds the maximum permissible areas for Group III according to IEC 60079-0: 2011 clause 7.4:3. Therefore, when the probe is used in a potentially dust explosive atmosphere group III, appropriate measures must be taken to prevent electrostatic discharge (i.e. only clean with a damp cloth).
4. ½” NPT threads need to be sealed for dust and water ingress protection, IP 66, IP 67 or “Ex t”. EPL Da or Db is required.

**I7 IECEx Intrinsic Safety**

**Certificate** IECEx NEM 06.0001X  
**Standards** IEC 60079-0:2011, IEC 60079-1:2014-06, IEC 60079-11:2011, IEC 60079-26:2014, IEC 60079-31:2013  
**Markings** Ex ia IIC T4 Ga  
 -55 °C ≤ Ta ≤ +60 °C (FIELDBUS) / +70 °C (HART)  
 Ex ia IIIC T69 °C/T79 °C Da  
 -50 °C ≤ Ta ≤ +60 °C (FIELDBUS) / +70 °C (HART)

**Special Conditions for Safe Use (X):**

1. The intrinsically safe circuits do not withstand the 500V AC test as specified in IEC 60079-11 clause 6.3.13.
2. Potential ignition hazards by impact or friction need to be considered according to IEC 60079-0:2011 clause 8.3 (for EPL Ga and EPL Gb), and clause 8.4 (for EPL Da and EPL Db), when the transmitter enclosure and antennas exposed to the exterior atmosphere of the tank, is made with light metals containing aluminium or titanium. The end user shall determine the suitability with regard to avoid hazards from impact and friction.
3. Parts of the sensor probes for type 5300 are non-conducting material covering metal surfaces and the area of the non-conducting part exceeds the maximum permissible areas for Group III according to IEC 60079-0: 2011 clause 7.4:3. Therefore, when the antenna is used in a potentially explosive atmosphere group III, EPL Da, appropriate measures must be taken to prevent electrostatic discharge.
4. The painted transmitter housing is non-conducting and exceeds the maximum permissible areas for Group III according to IEC 60079-0: 2011 clause 7.4:3. Therefore, when the probe is used in a potentially dust explosive atmosphere group III, appropriate measures must be taken to prevent electrostatic discharge (i.e. only clean with a damp cloth).
5. ½” NPT threads need to be sealed for dust and water ingress protection, IP 66, IP 67 or “Ex t”. EPL Da or Db is required.

	Ui	Ii	Pi	Ci	Li
Entity parameters HART	30 V	130 mA	1 W	0 µF	Negligible
Entity parameters Fieldbus	30 V	300 mA	1.5 W	4.95 nF	Negligible

**IG IECEx FISCO**

**Certificate** IECEx NEM 06.0001X  
**Standards** IEC 60079-0:2011, IEC 60079-1:2014-06, IEC 60079-11:2011, IEC 60079-26:2014, IEC 60079-31:2013  
**Markings** Ex ia IIC T4 Ga (-55 °C ≤ Ta ≤ +60 °C)  
 Ex ia/ib IIC T4 Ga/Gb (-55 °C ≤ Ta ≤ +60 °C)  
 Ex ia IIIC T69 °C Da (-50 °C ≤ Ta ≤ +60 °C)  
 Ex ia/ib IIIC T69 °C Da/Db (-50 °C ≤ Ta ≤ +60 °C)

**Special Conditions for Safe Use (X):**

1. The intrinsically safe circuits do not withstand the 500V AC test as specified in IEC 60079-11 clause 6.3.13.

2. Potential ignition hazards by impact or friction need to be considered according to IEC 60079-0:2011 clause 8.3 (for EPL Ga and EPL Gb), and clause 8.4 (for EPL Da and EPL Db), when the transmitter enclosure and antennas exposed to the exterior atmosphere of the tank, is made with light metals containing aluminium or titanium. The end user shall determine the suitability with regard to avoid hazards from impact and friction.
3. Parts of the sensor probes for type 5300 are non-conducting material covering metal surfaces and the area of the non-conducting part exceeds the maximum permissible areas for Group III according to IEC 60079-0: 2011 clause 7.4:3 Therefore, when the antenna is used in a potentially explosive atmosphere group III, EPL Da, appropriate measures must be taken to prevent electrostatic discharge.
4. The painted transmitter housing is non-conducting and exceeds the maximum permissible areas for Group III according to IEC 60079-0: 2011 clause 7.4:3. Therefore, when the probe is used in a potentially dust explosive atmosphere group III, appropriate measures must be taken to prevent electrostatic discharge (i.e. only clean with a damp cloth).
5. The Ex ia version of model 5300 FISCO field device may be supplied by an [Ex ib] FISCO power supply when the power supply is certified with three separate safety current limiting devices and voltage limitation which meets the requirements for type Ex ia.
6. ½” NPT threads need to be sealed for dust and water ingress protection, IP 66, IP 67 or “Ex t”, EPL Da or Db is required.

	Ui	Ii	Pi	Ci	Li
FISCO parameters	17.5 V	380 mA	5.32 W	4.95 nF	<1 µH

### N7 IECEx Type N

- Certificate** IECEx NEM 10.0005X
- Standards** IEC 60079-0:2011, IEC 60079-11:2011, IEC 60079-15:2010, IEC 60079-31:2013
- Markings** Ex nA ic IIC T4 Gc  
 Ex ic IIC T4 Gc  
 Ex tc IIIC T69 °C (FIELDBUS) /T79 °C (HART) Dc  
 -50 °C ≤ Ta ≤ +60 °C (FIELDBUS) /+70 °C (HART)

#### Special Conditions for Safe Use (X):

1. The transmitter circuits does not withstand 500V AC dielectric strength test according to EN 60079-11 clause 6.3.13 due to earth connected transient suppressing devices. Appropriate measures have to be considered by installation.

	Ui	Ii	Pi	Ci	Li
Safety parameters HART	42.4 V	23 mA	1 W	7.25 nF	Negligible
Safety parameters Fieldbus	32 V	21 mA	0.7 W	4.95 nF	Negligible

## Brazil

### E2 INMETRO Flameproof

- Certificate** UL-BR 17.0188X
- Standards** ABNT NBR IEC 60079-0:2013, ABNT NBR IEC 60079-1:2016, ABNT NBR IEC 60079-11:2013, ABNT NBR IEC 60079-26:2016, ABNT NBR IEC 60079-31:2014
- Markings** Ex db ia IIC T4 Ga/Gb (-55 °C ≤ T<sub>amb</sub> ≤ +60 °C /+70 °C)  
 Ex ta IIIC T69 °C/T79 °C Da (-40 °C ≤ T<sub>amb</sub> ≤ +60 °C /+70 °C)  
 Um=250 V<sub>ac</sub>, IP66/67

**Special Conditions for Safe Use (X):**

1. See certificate for Specific Conditions.

**I2 INMETRO Intrinsic Safety**

**Certificate** Certificate: UL-BR 17.0188X  
**Standards** ABNT NBR IEC 60079-0:2013 , ABNT NBR IEC 60079-11:2013, ABNT NBR IEC 60079-26:2016, ABNT NBR IEC 60079-31:2014  
**Markings** Ex ia IIC T4 Ga (- 55 °C ≤ T<sub>amb</sub> ≤ +60 °C /+70 °C)  
 Ex ia IIIC T69 °C/T79 °C Da (- 50 °C ≤ T<sub>amb</sub> ≤ +60 °C /+70 °C)

**Special Conditions for Safe Use (X):**

1. See certificate for Specific Conditions.

	Ui	Ii	Pi	Ci	Li
Entity parameters HART	30 V <sub>dc</sub>	130 mA	1.0 W	7.26 nF	Negligible
Entity parameters Fieldbus	30 V <sub>dc</sub>	300 mA	1.5 W	4.95 nF	Negligible

**IB INMETRO FISCO**

**Certificate** UL-BR 17.0188X  
**Standards** ABNT NBR IEC 60079-0:2013, ABNT NBR IEC 60079-11:2013, ABNT NBR IEC 60079-26:2016, ABNT NBR IEC 60079-31:2014  
**Markings** Ex ia IIC T4 Ga (- 55 °C ≤ T<sub>amb</sub> ≤ +60 °C)  
 Ex ia/ib IIC T4 Ga/Gb (- 55 °C ≤ T<sub>amb</sub> ≤ +60 °C)  
 Ex ia IIIC T69 °C Da (- 50 °C ≤ T<sub>amb</sub> ≤ +60 °C)  
 Ex ia/ib IIIC T69 °C Da/Db (- 50 °C ≤ T<sub>amb</sub> ≤ +60 °C)

**Special Conditions for Safe Use (X):**

1. See certificate for Specific Conditions.

	Ui	Ii	Pi	Ci	Li
FISCO parameters	17.5 V <sub>dc</sub>	380 mA	5.32 W	4.95 nF	<1 μH

**China**

**E3 China Flameproof**

**Certificate** GYJ16.1095X  
**Standards** GB 3836.1/2/4/20-2010, GB 12476.1/5-2013, GB 12476.4-2010  
**Markings** Ex d ia IIC T4 Ga/Gb (-40 °C ≤ Ta ≤ +60 °C/+70 °C)  
 Ex tD A20 IP 66/67 T69 °C /T79 °C (-40 °C ≤ Ta ≤ +60 °C/+70 °C)

**Special Conditions for Safe Use (X):**

1. See certificate for Specific Conditions.

### I3 China Intrinsic Safety

**Certificate** GYJ16.1095X  
**Standards** GB 3836.1/2/4/20-2010, GB 12476.1/5-2013, GB 12476.4-2010  
**Markings** Ex ia IIC T4 Ga (-55 °C ≤ Ta ≤ +60 °C/+70 °C)  
 Ex iaD 20 T69 °C /T79 °C (-50 °C ≤ Ta ≤ +60 °C/+70 °C)

**Special Conditions for Safe Use (X):**

1. See certificate for Specific Conditions.

	Ui	Ii	Pi	Ci	Li
Entity parameters HART	30 V	130 mA	1 W	7.26 nF	0 mH
Entity parameters Fieldbus	30 V	300 mA	1.5 W	4.95 nF	0 mH

### IC China FISCO

**Certificate** GYJ16.1095X  
**Standards** GB 3836.1/2/4/20-2010, GB 12476.4/5-2013, GB 12476.1-2010  
**Markings** Ex ia IIC T4 Ga (-55 °C ≤ Ta ≤ +60 °C)  
 Ex ia/ib IIC T4 Ga/Gb (-55 °C ≤ Ta ≤ +60 °C)  
 Ex iaD 20 T69 (-50 °C ≤ Ta ≤ +60 °C)  
 Ex iaD/ibD 20/21 T69 °C (-50 °C ≤ Ta ≤ +60 °C)

**Special Conditions for Safe Use (X):**

1. See certificate for Specific Conditions.

	Ui	Ii	Pi	Ci	Li
FISCO parameters	17.5 V	380 mA	5.32 W	4.95 nF	<0.001 mH

### N3 China Type N

**Certificate** GYJ18.1331X  
**Standards** GB 3836.1-2010, GB 3836.4-2010, GB 3836.8-2014  
**Markings** Ex nA ic IIC T4 Gc (-50 °C ≤ Ta ≤ +60 °C/+70 °C)  
 Ex ic IIC T4 Gc (-50 °C ≤ Ta ≤ +60 °C/+70 °C)

**Special Conditions for Safe Use (X):**

1. See certificate for Specific Conditions.

	Ui	Ii	Pi	Ci	Li
Safety parameters HART	42.4 V	23 mA	1 W	7.25 nF	Negligible
Safety parameters Fieldbus	32 V	21 mA	0.7 W	4.95 nF	Negligible

## Technical Regulations Customs Union (EAC)

### EM Technical Regulations Customs Union (EAC) Flameproof

**Certificate** EAЭC RU C-SE.EX01.B.0086/19  
**Markings** Ga/Gb Ex db ia IIC T4...T1 X, (-55 °C ≤ Ta ≤ +60 °C/+70 °C)  
 Ex ta IIIC T69 °C/T79 °C Da X (-40 °C ≤ Ta ≤ +60 °C/+70 °C)

**Special Conditions for Safe Use (X):**

1. See certificate for Specific Conditions.

### IM Technical Regulations Customs Union (EAC) Intrinsic Safety

**Certificate** EAЭC RU C-SE.EX01.B.0086/19  
**Markings** 0Ex ia IIC T4...T1 Ga X, (-55 °C ≤ Ta ≤ +60 °C/+70 °C)  
 Ex ia IIIC T69 °C/T79 °C Da X, (-50 °C ≤ Ta ≤ +60 °C/+70 °C)

**Special Conditions for Safe Use (X):**

1. See certificate for Specific Conditions.

	Ui	Ii	Pi	Ci	Li
Entity parameters HART	30 V	130 mA	1 W	7.26 nF	0 mH
Entity parameters Fieldbus	30 V	300 mA	1.5 W	4.95 nF	0 mH

### IN Technical Regulations Customs Union (EAC) FISCO

**Certificate** EAЭC RU C-SE.EX01.B.0086/19  
**Markings** 0Ex ia IIC T4...T1 Ga X, (-55 °C ≤ Ta ≤ +60 °C)  
 Ga/Gb Ex ia/ib IIC T4...T1 X, (-55 °C ≤ Ta ≤ +60 °C)  
 Ex ia IIIC T69 °C Da X, (-50 °C ≤ Ta ≤ +60 °C)  
 Ex ia/ib IIIC T69 °C Da/Db X, (-50 °C ≤ Ta ≤ +60 °C)

**Special Conditions for Safe Use (X):**

1. See certificate for Specific Conditions.

	Ui	Ii	Pi	Ci	Li
FISCO parameters	17.5 V	380 mA	5.32 W	4.95 nF	0 mH

## Japan

### E4 Flameproof

**Certificate** CML 17JPN1334X  
**Markings** Ex d ia IIC T4 Ga/Gb (-40 °C ≤ Ta ≤ +60 °C/+70 °C)

**Special Conditions for Safe Use (X):**

1. See certificate for Specific Conditions.

## Republic of Korea

### EP Flameproof HART

**Certificate** KTL 15-KB4BO-0297X, 13-KB4BO-0019X

**Markings** Ex d ia IIC T4 Ga/Gb

#### Special Conditions for Safe Use (X):

1. See certificate for Specific Conditions.

### EP Flameproof Fieldbus

**Certificate** KTL 12-KB4BO-0179X

**Markings** Ex d ia IIC T4

#### Special Conditions for Safe Use (X):

1. See certificate for Specific Conditions.

## India

### Flameproof, Intrinsically safe

**Certificate** P392482/1

**Markings** Ex db ia IIC T4 Ga /Gb  
Ex ia IIC T4 Ga

#### Special Conditions for Safe Use (X):

1. See certificate for Specific Conditions.

## Ukraine

### Flameproof, Intrinsically Safe

**Certificate** UA.TR.047.C.0352-13

**Markings** 0 Ex ia IIC T4 X,  
1 Ex d ia IIC T4 X

#### Special Conditions for Safe Use (X):

1. See certificate for Specific Conditions.



## Uzbekistan

### Safety (import)

**Certificate** UZ.SMT.01.342.2017121

### Combinations

- KA** Combination of E1, E5 and E6
- KB** Combination of E1, E5 and E7
- KC** Combination of E1, E6 and E7
- KD** Combination of E5, E6 and E7
- KE** Combination of I1, I5 and I6
- KF** Combination of I1, I5 and I7
- KG** Combination of I1, I6 and I7
- KH** Combination of I5, I6 and I7
- KI** Combination of IA, IE and IF
- KJ** Combination of IA, IE and IG
- KK** Combination of IA, IF and IG
- KL** Combination of IE, IF and IG

### Additional certifications

#### SBS American Bureau of Shipping (ABS) Type Approval

**Certificate** 15-LD1340199-1-PDA

**Intended Use** For use on ABS Classed Vessels and Offshore Facilities in accordance with ABS rules and International Standards.

---

**Note**

Housing material A, Aluminum, is not to be used on open decks.

---

#### SBV Bureau Veritas (BV) Type Approval

**Certificate** 22378\_B3 BV

**Requirements** Bureau Veritas rules for classification of steel ships. EC Code: 41SB

**Application** Class Notations: AUT-UMS, AUT-CCS, AUT-PORT and AUT-IMS.

---

**Note**

Housing material A, Aluminum, is not to be used on open decks.

---

#### SDN Det Norske Veritas Germanischer Lloyd (DNV GL) Type Approval

**Certificate** TAA000020G

**Intended Use** DNV GL rules for classification – Ships, offshore units, and high speed and light craft

**Table 35: Application**

Location classes	
Temperature	D
Humidity	B
Vibration	A
EMC	B
Enclosure	C

**Note**

Housing material A, Aluminum, is not to be used on open decks.

**SKR Korean Register (KR) Type Approval**

**Certificate** CPH05152-AE001

**Requirements** Pt. 6, Ch. 2, Art. 301 of the Rules for Classification of Steel Ships.

**Note**

Housing material A, Aluminum, is not to be used on open decks.

**SLL Lloyds Register (LR) Type Approval**

**Certificate** 15/20053

**Application** Marine applications for use in environmental categories ENV1, ENV2, ENV3 and ENV5.

**Note**

Housing material A, Aluminum, is not to be used on open decks.

**U1 Overfill prevention**

**Certificate** Z-65.16-476

**Application** TÜV tested and approved by DIBt for overfill prevention according to the German WHG regulations.

**J8 EN Boiler (European Boiler Approval in accordance with EN 12952-11 and EN 12953-9)**

**Note**

Suitable for use as a level sensor part of a limiting device in accordance with EN 12952-11 and EN 12953-9.

**QT Safety-certified to IEC 61508:2010 with certificate of FMEDA data**

**Certificate** exida ROS 13-06-005 C001 R2.1

**Suitable for intended use**

Compliant with NAMUR NE 95, version 22.01.2013 “Basic Principles of Homologation”

## Pattern Approval

### GOST Belarus

**Certificate** No. 10263

### GOST Kazakhstan

**Certificate** No. 15466

### GOST Russia

**Certificate** SE.C.29.010.A No.51062/1

### GOST Uzbekistan

**Certificate** 02.7101

### China Pattern Approval

**Certificate** CPA 2012-L135

## Conduit plugs and adapters

### IECEX Flameproof and Increased Safety

**Certificate** IECEX UL 18.0016X

**Standards** IEC60079-0:2011, IEC60079-1:2014, IEC60079-7:2015, IEC60079-31:2014

**Markings** Ex db eb IIC Gb; Ex ta IIIC Da

### ATEX Flameproof and Increased Safety

**Certificate** DEMKO 18 ATEX 1986X

**Standards** EN 60079-0:2012+A11:2013, EN 60079-1:2014, EN 60079-7:2015, EN 60079-31:2014

**Markings**  II 2 G Ex db eb IIC Gb

 II 1 D Ex ta IIIC Da

**Table 36: Conduit Plug Thread Sizes**

Thread	Identification mark
M20x1.5-6g	M20
½ - 14 NPT	½ NPT

**Table 37: Thread Adapter Thread Sizes**

<b>Male thread</b>	<b>Identification mark</b>
M20 x 1.5 – 6g	M20
½- 14 NPT	½ - 14 NPT
<b>Female thread</b>	<b>Identification mark</b>
M20 x 1.5 – 6H	M20
½ - 14 NPT	½ - 14 NPT

**Specific Conditions for Safe Use (X):**

1. The Blanking Elements shall not be used with an adapter.
2. Only one adapter shall be used with any single cable entry on the associated equipment.
3. It is the end user's responsibility to ensure that the ingress protection rating is maintained at the interface of the equipment and the blanking element/adapter.
4. Suitability of the temperature of the devices is to be determined during end-use with suitably rated equipment.

# Dimensional drawings

**Figure 31: Rigid Single Lead Probe with Flange Connection**

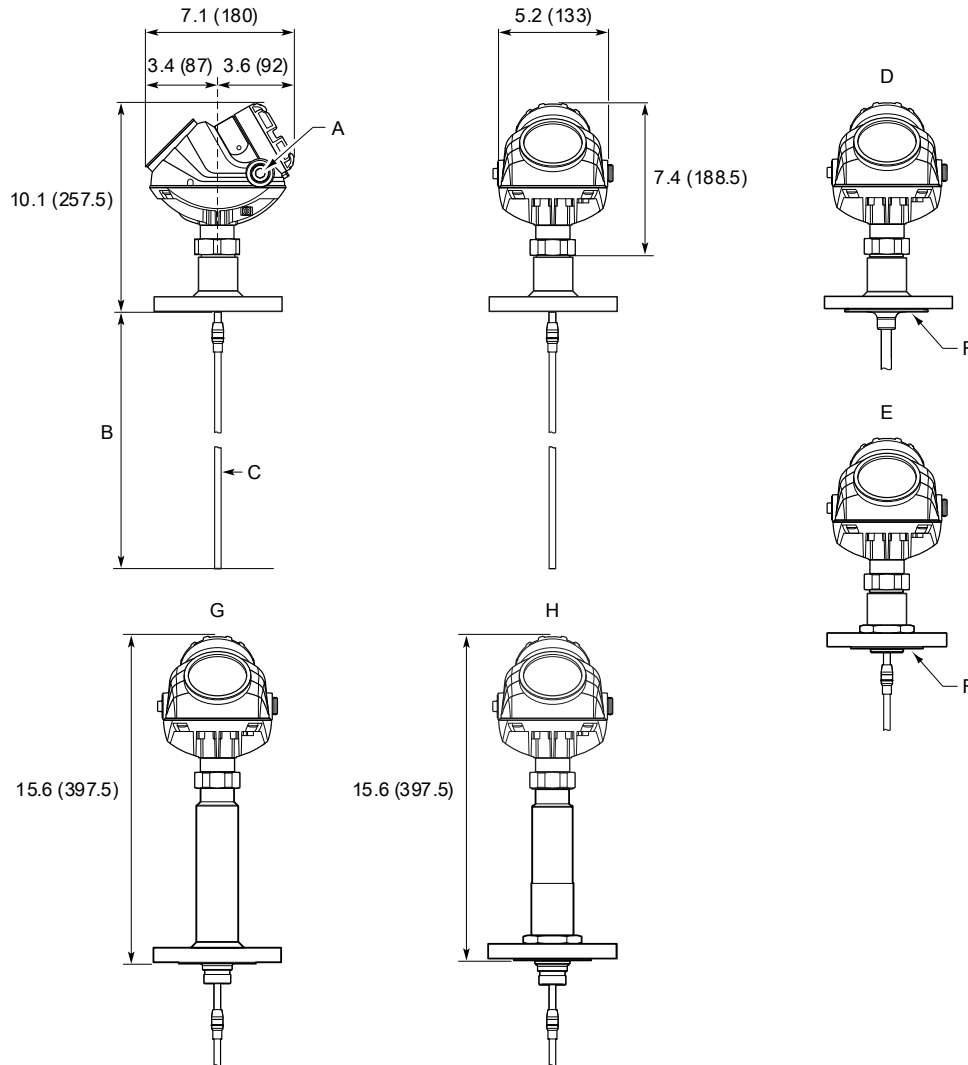

- A. 1/2 - 14 NPT; optional adapters: M20x1.5, eurofast® and minifast®
- B. L ≤ 10 ft. (3 m) for Ø 0.31 (8); L ≤ 20 ft. (6 m) for Ø 0.51 (13)
- C. Ø 0.31 (8); Ø 0.51 (13); Ø 0.47 (12) for PTFE covered probe
- D. PTFE covered probe and protective plate
- E. Alloy probe and protective plate
- F. The PTFE and Alloy probes are designed with a protective plate.
- G. HTHP/HP/C version
- H. HTHP/HP Plate Design (Option for Alloy versions)

Dimensions are in inches (millimeters).

**Figure 32: Rigid Single Lead Probe with Tri-Clamp® Connection**

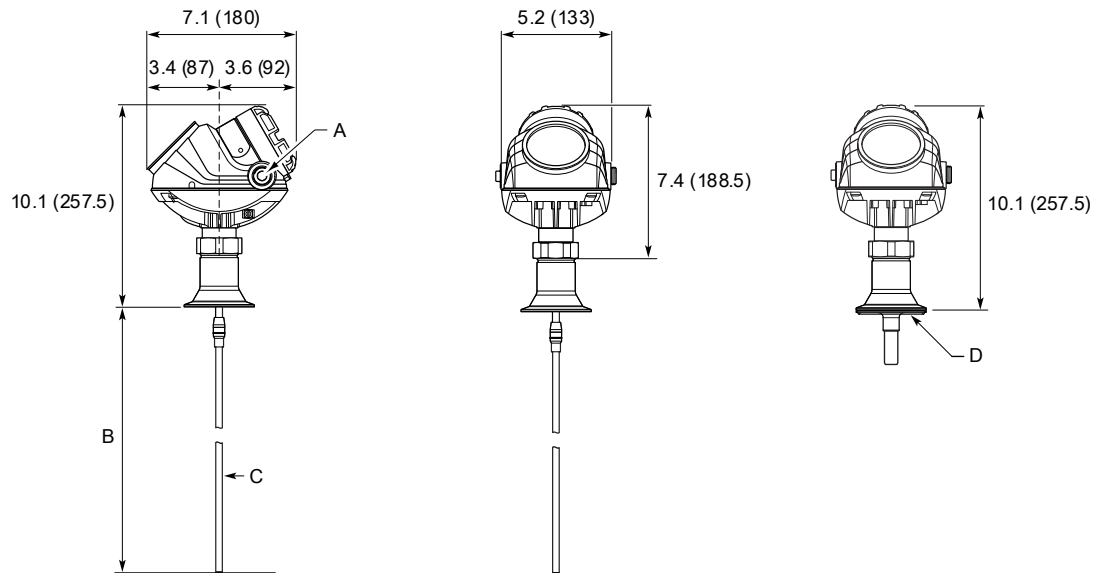

- A. 1/2 - 14 NPT; optional adapters: M20x1.5, eurofast and minifast
- B. L ≤ 10 ft. (3 m) for Ø 0.31 (8); L ≤ 20 ft. (6 m) for Ø 0.51 (13)
- C. Ø 0.31 (8); Ø 0.51 (13); Ø 0.47 (12) for PTFE covered probe
- D. PTFE covered probe and protective plate

Dimensions are in inches (millimeters).

**Figure 33: Rigid Single Lead with Threaded Connection**

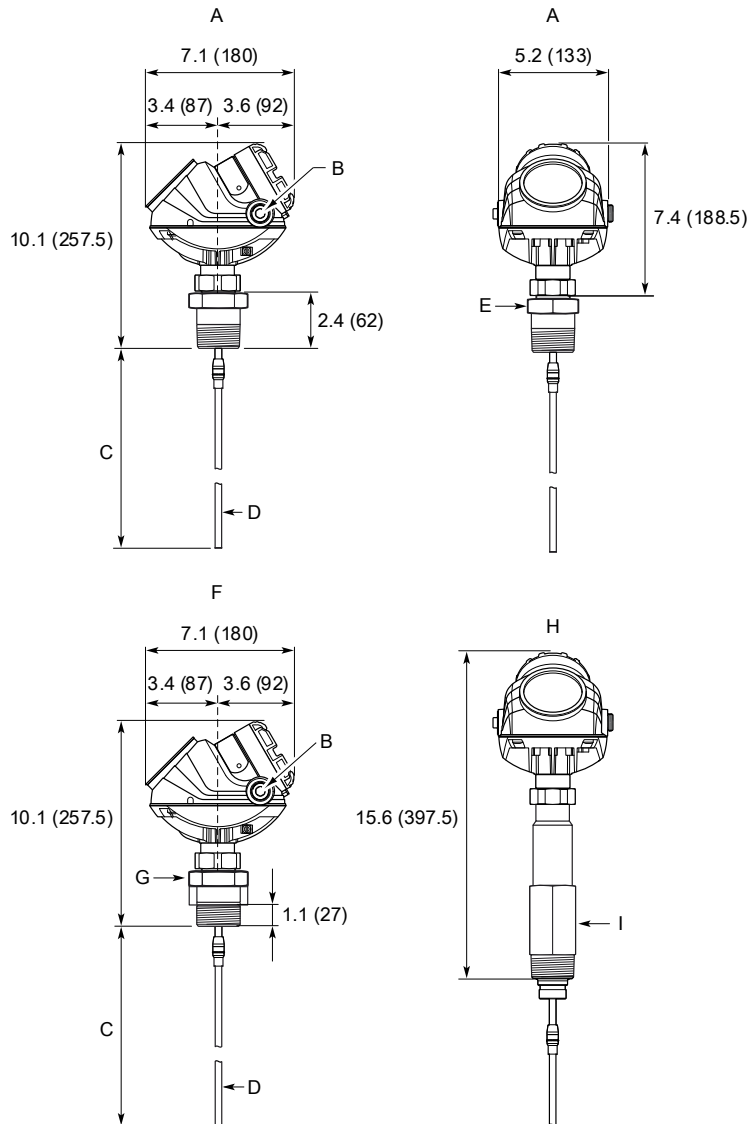

- A. NPT 1 1/2 in.
- B. 1/2 - 14 NPT; optional adapters: M20x1.5, eurofast and minifast
- C. L ≤ 10 ft. (3 m) for Ø 0.31 (8); L ≤ 20 ft. (6 m) for Ø 0.51 (13)
- D. Ø 0.31 (8); Ø 0.51 (13); Ø 0.47 (12) for PTFE covered probe
- E. 1 in. / 1 1/2 in.: s52; 2 in.: s60
- F. G 1 1/2 in.
- G. 1 in.: s52; 1 1/2 in.: s60
- H. NPT 1 1/2, G 1 1/2 in. (HTHP/HP/C version)
- I. NPT: s50; G: s60

Dimensions are in inches (millimeters).

Figure 34: Segmented Rigid Single Lead Probe with Flange Connection

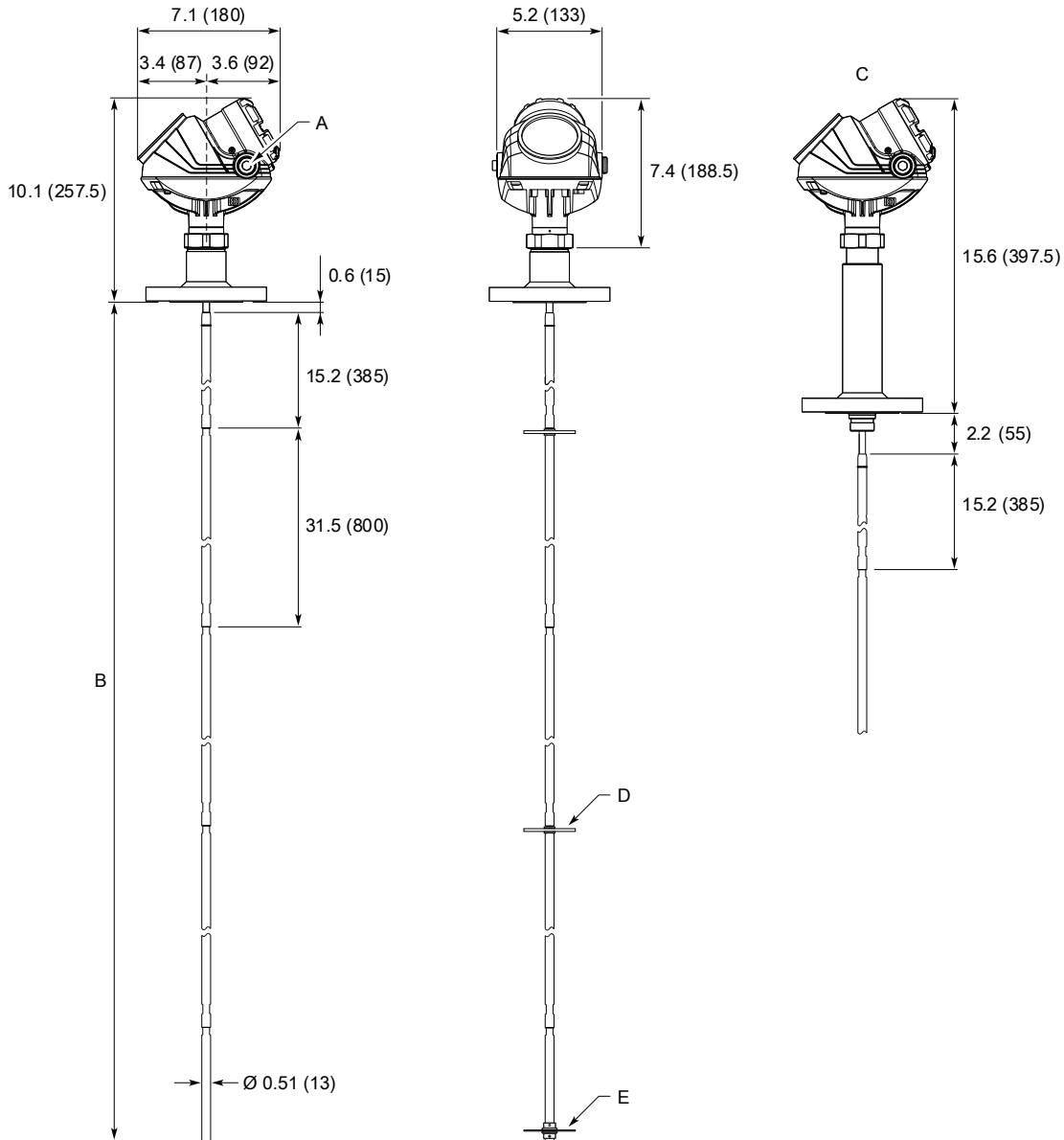

- A. 1/2 - 14 NPT; optional adapters: M20x1.5, eurofast and minifast
- B. L ≤ 33 ft. (10 m)
- C. HTHP/HP/C version
- D. Optional: PTFE centering disc
- E. Optional: Bottom centering disc (SST or PTFE)

Dimensions are in inches (millimeters).



Figure 35: Segmented Rigid Single Lead Probe with Threaded Connection

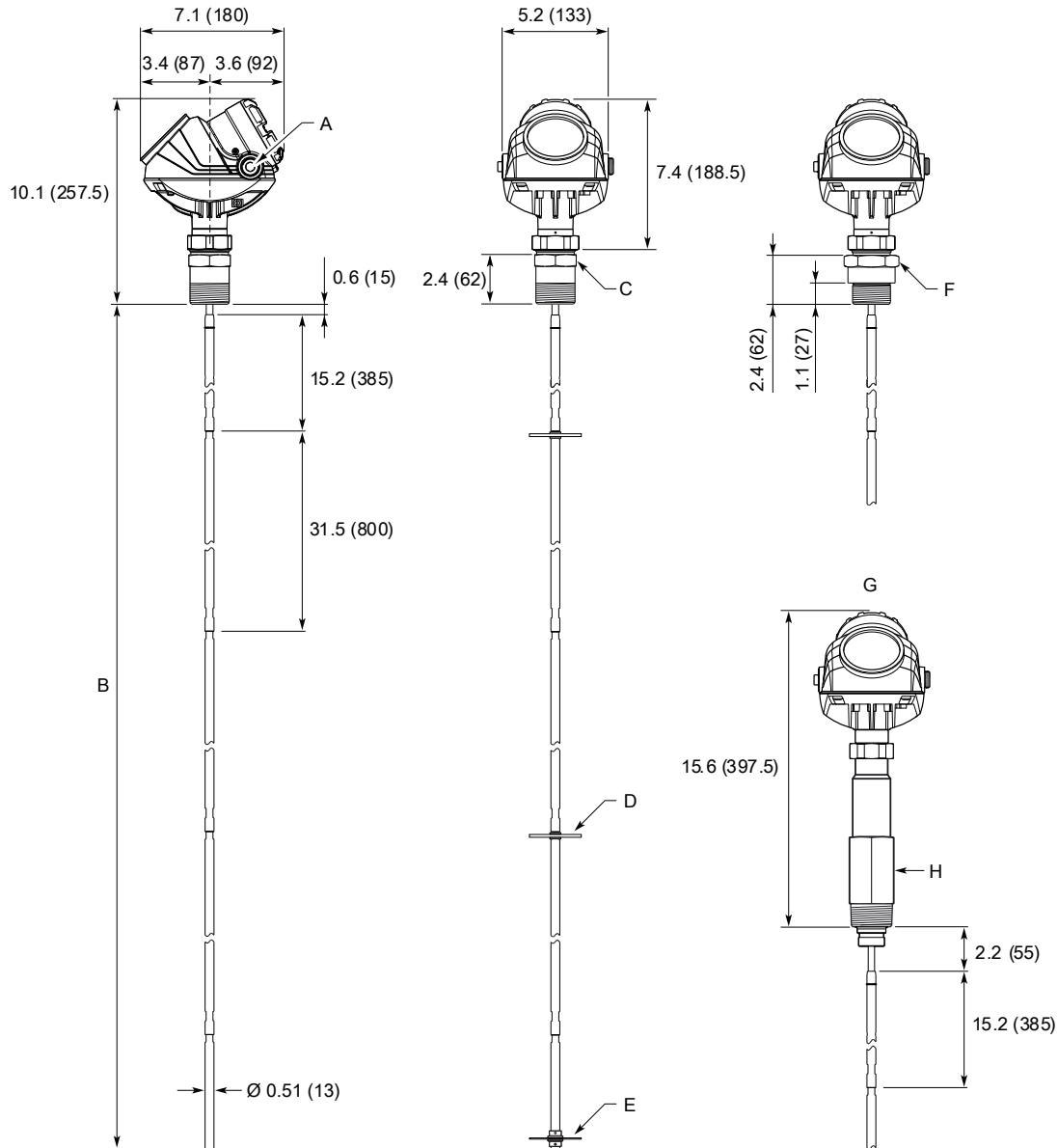

- A. 1/2 - 14 NPT; optional adapters: M20x1.5, eurofast and minifast
- B. L ≤ 33 ft. (10 m)
- C. NPT 1 in., s52; NPT 1 1/2 in., s52; NPT 2 in., s60
- D. Optional: PTFE centering disc
- E. Optional: Bottom centering disc (SST or PTFE)
- F. BSP-G 1 in., s52; BSP-G 1 1/2 in., s60
- G. HTHP/HP/C version
- H. NPT 1 1/2 in., s50; BSP-G 1 1/2 in., s60

Dimensions are in inches (millimeters).

Figure 36: Single Rigid Vapor Probe for 2-in. Chambers

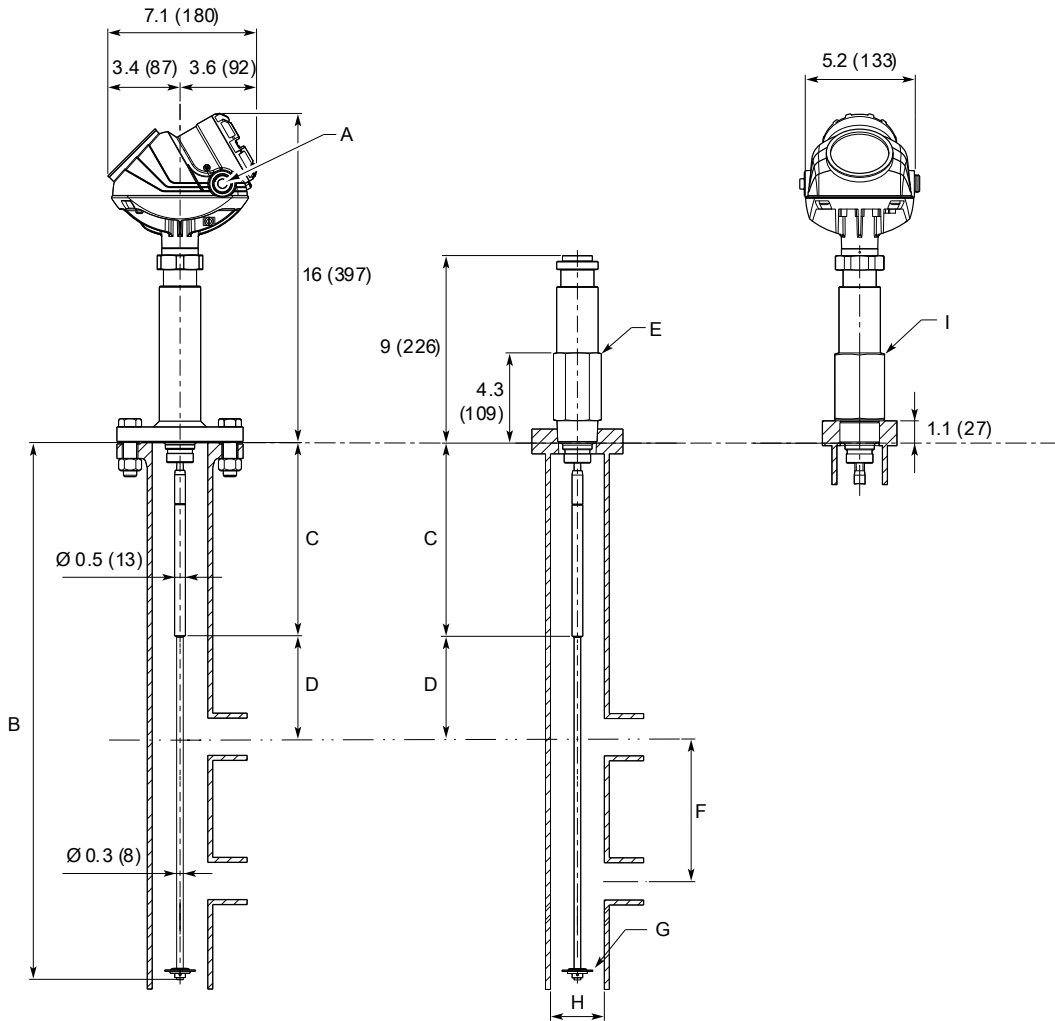

- A. 1/2 - 14 NPT; optional adapters: M20x1.5, eurofast and minifast
- B.  $L \leq 10 \text{ ft. (3 m)}$
- C. Short reflector: 13.8 (350); Long reflector: 19.7 (500)
- D. Minimum 8.3 in. (210 mm) distance between water surface and reflector end
- E. NPT 1 1/2 in., s50
- F. Min. 12 in. (300 mm)
- G. 1 1/2-in. centering disc, Ø 1.46 (37)
- H. Pipe inner diameter: Ø 1.5 (38) - Ø 2.05 (52)
- I. BSP-G 1 1/2 in., s60

Dimensions are in inches (millimeters).

**Figure 37: Flexible Single Lead Probe with Flange Connection**

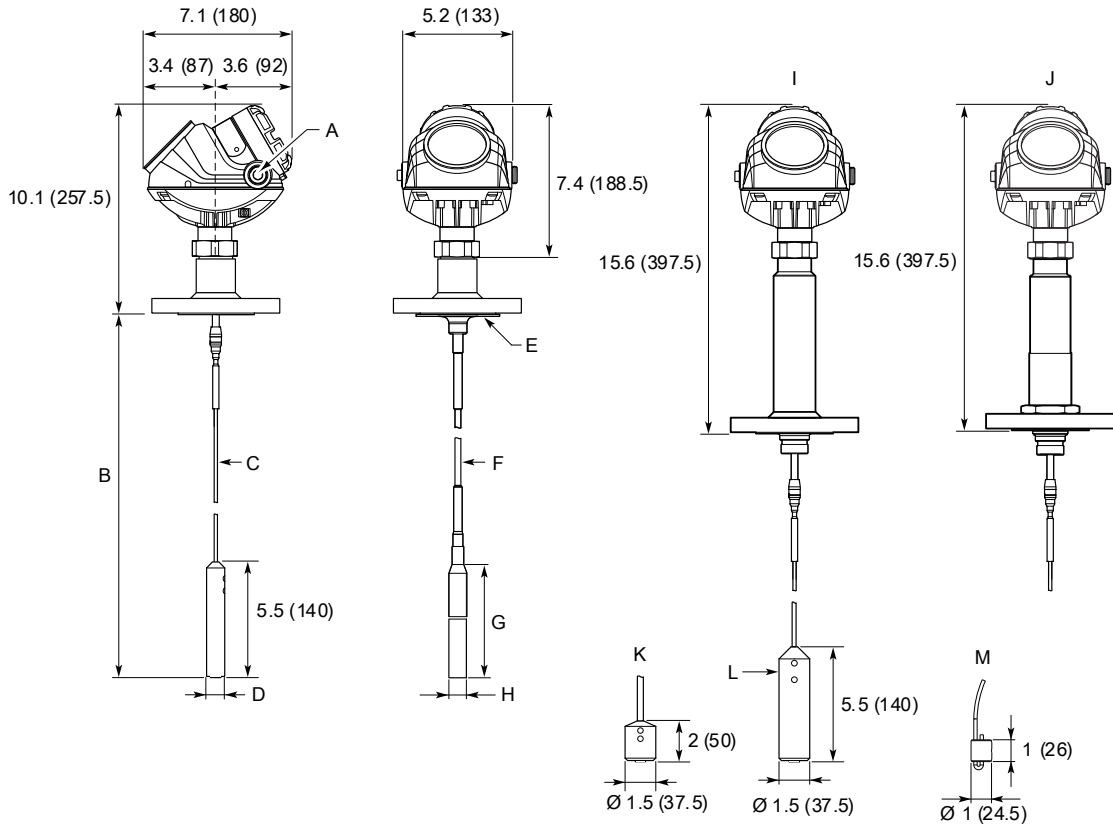

- A. 1/2 - 14 NPT; optional adapters: M20x1.5, eurofast and minifast
- B. L ≤ 164 ft. (50 m)
- C. Ø 0.16 (4); Ø 0.24 (6)
- D. 4 mm probe: Ø 0.86 (22); 6 mm probe: Ø 1.10 (28)
- E. The PTFE covered probe is designed with a protective plate
- F. Ø 0.28 (7) for PTFE covered probe
- G. 17.1 (434) for PTFE covered probe
- H. Ø 0.88 (22.5) for PTFE covered probe
- I. HTHP/HP/C version
- J. HTHP/HP/C Plate Design (Option for Alloy versions)
- K. Short weight (option W2)
- L. Heavy weight (option W3)
- M. Chuck

Dimensions are in inches (millimeters).

Figure 38: Flexible Single Lead Probe with Tri-Clamp Connection

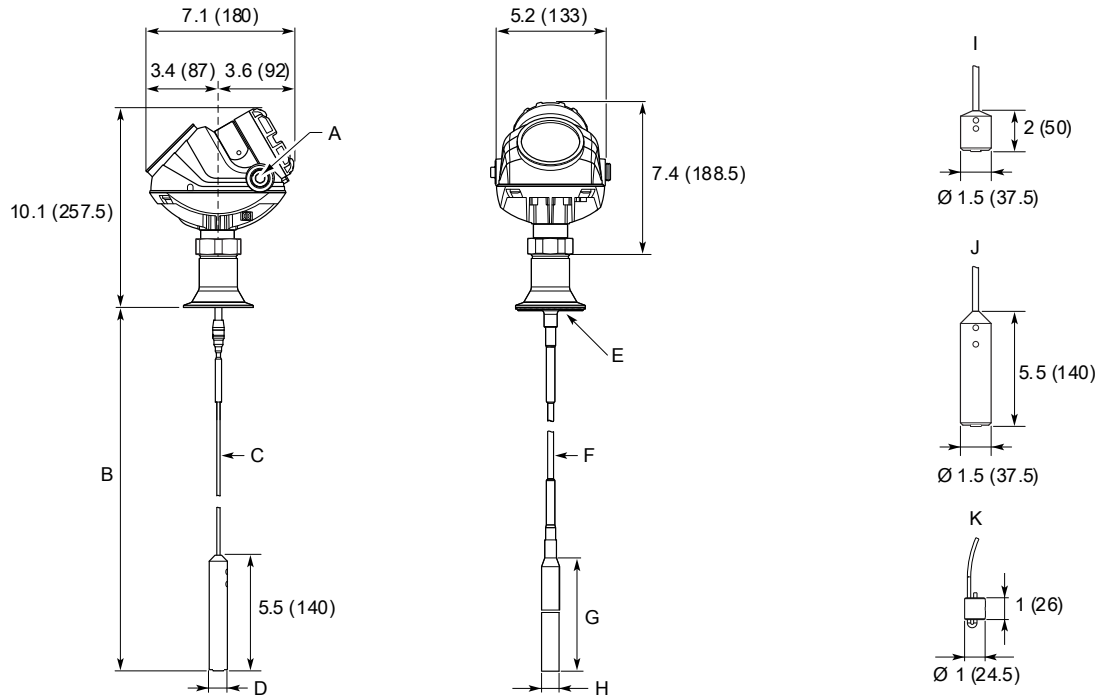

- A. 1/2 - 14 NPT; optional adapters: M20x1.5, eurofast and minifast
- B.  $L \leq 164$  ft. (50 m)
- C.  $\varnothing 0.16$  (4);  $\varnothing 0.24$  (6)
- D. 4 mm probe:  $\varnothing 0.86$  (22); 6 mm probe:  $\varnothing 1.10$  (28)
- E. The PTFE covered probe is designed with a protective plate
- F.  $\varnothing 0.28$  (7) for PTFE covered probe
- G. 17.1 (434) for PTFE covered probe
- H.  $\varnothing 0.88$  (22.5) for PTFE covered probe
- I. Short weight (option W2)
- J. Heavy weight (option W3)
- K. Chuck

Dimensions are in inches (millimeters).

**Figure 39: Flexible Single Lead with Threaded Connection**

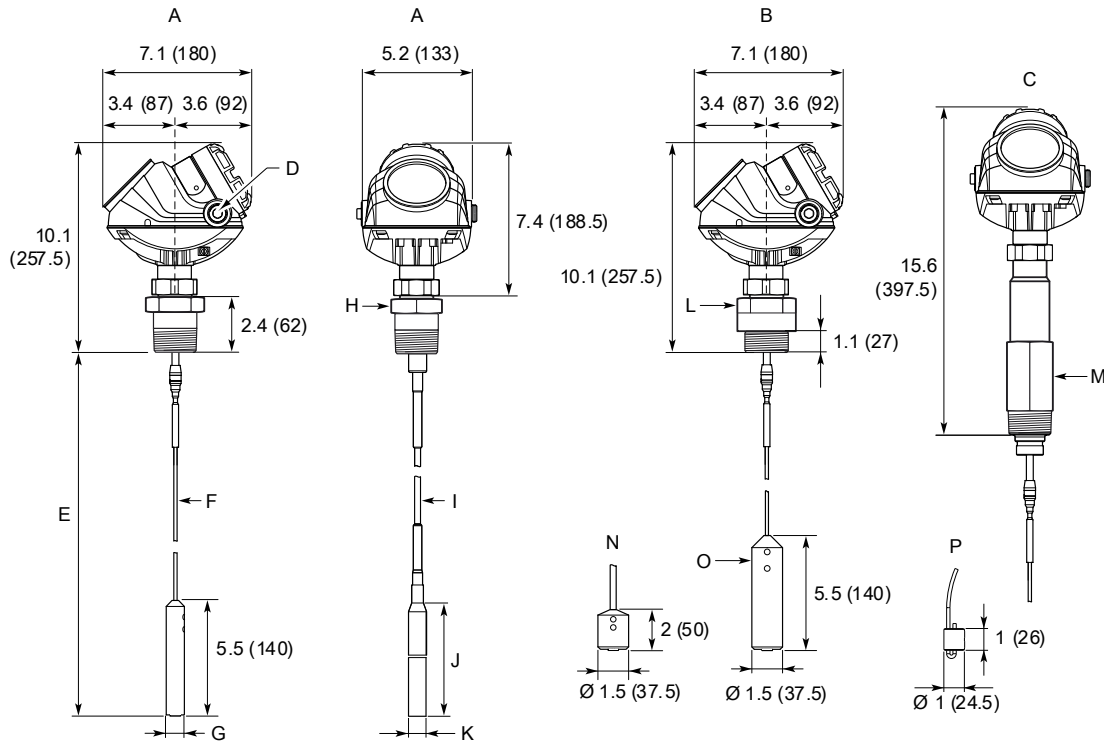

- A. NPT 1/1½/2 in.
- B. G 1/1½ in.
- C. NPT 1½, G 1½ in. (HTHP/HP/C version)
- D. ½ - 14 NPT; optional adapters: M20x1.5, eurofast and minifast
- E. L ≤ 164 ft. (50 m)
- F. Ø 0.16 (4); Ø 0.24 (6)
- G. 4 mm probe: Ø 0.86 (22); 6 mm probe: Ø 1.10 (28)
- H. 1 in. / 1½ in.: s52; 2 in.: s60
- I. Ø 0.28 (7) for PTFE covered probe
- J. 17.1 (434) for PTFE covered probe
- K. Ø 0.88 (22.5) for PTFE covered probe
- L. 1 in.: s52; 1½ in.: s60
- M. NPT: s50; G: s60
- N. Short weight (option W2)
- O. Heavy weight (option W3)
- P. Chuck

Dimensions are in inches (millimeters).

Figure 40: Coaxial probe with Flange Connection

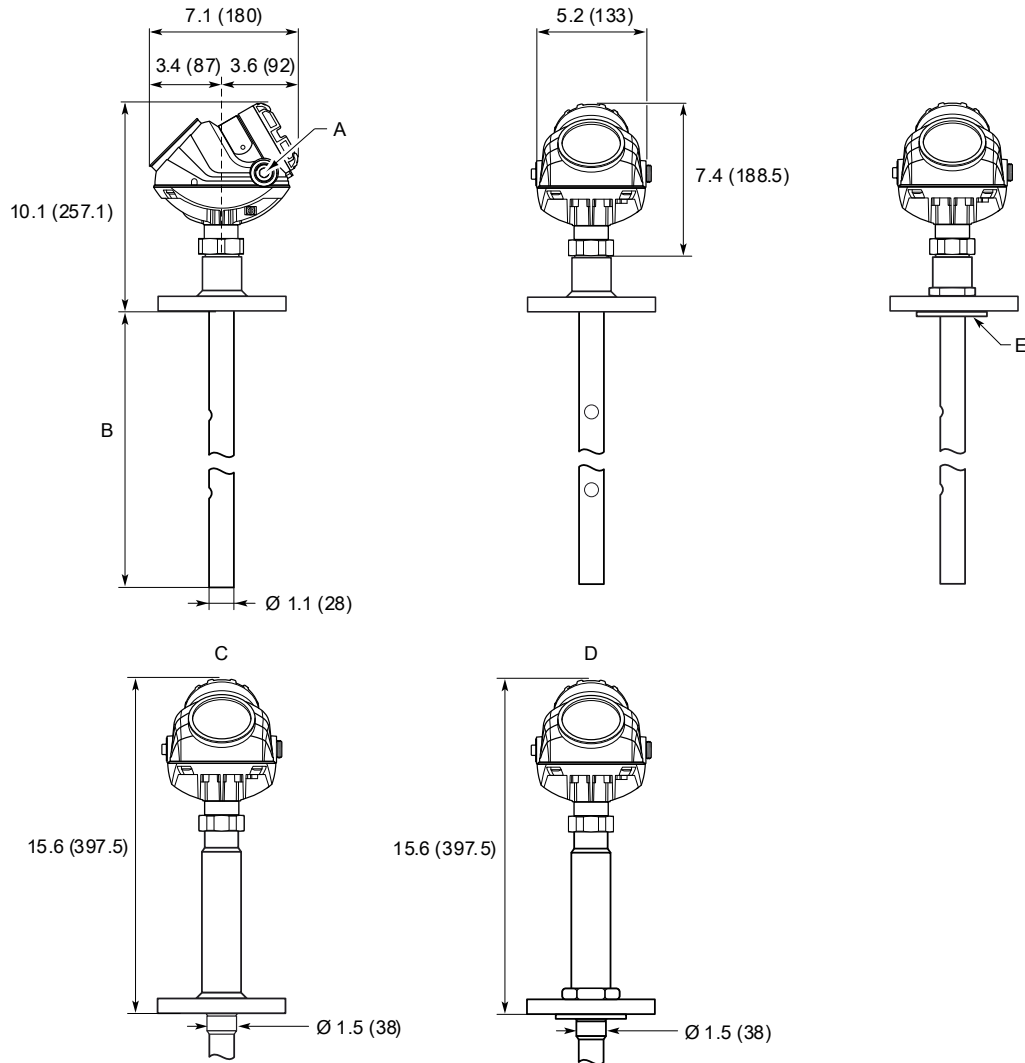

- A. 1/2 - 14 NPT; optional adapters: M20x1.5, eurofast and minifast
- B. L ≤ 20 ft. (6 m)
- C. HTHP/HP/C version
- D. HTHP/HP Plate Design (Option for Alloy versions)
- E. The Alloy probes are designed with a protective plate

Dimensions are in inches (millimeters).

**Figure 41: Coaxial Probe with Threaded Connection**

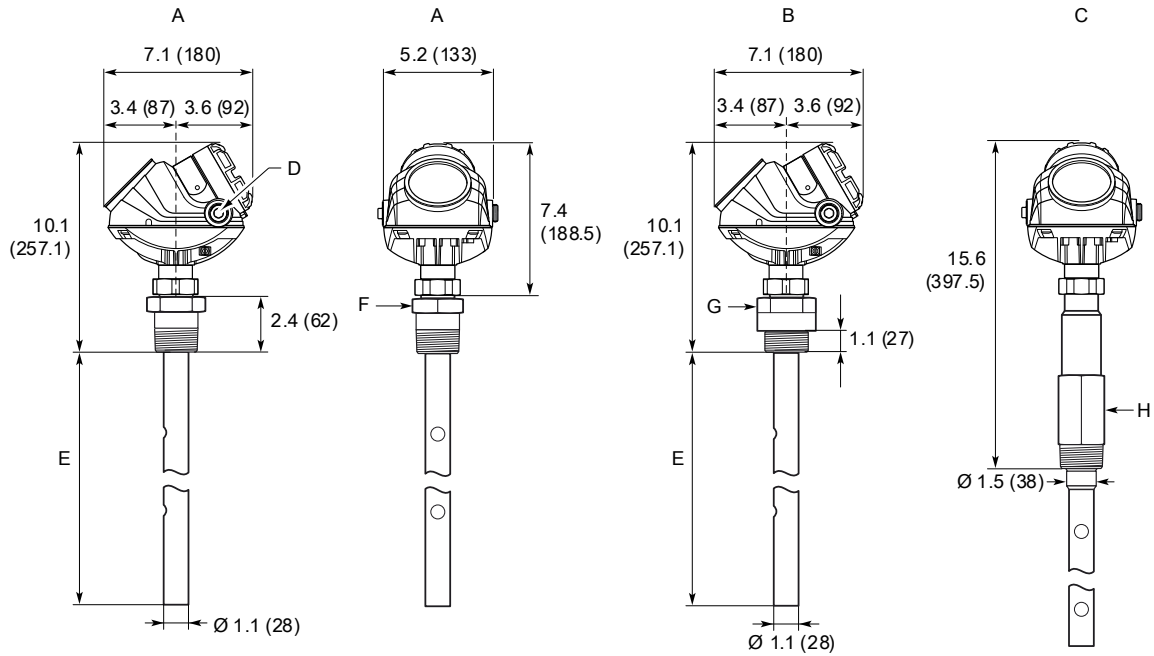

- A. NPT 1/1½/2 in.
- B. G 1/1½ in.
- C. NPT 1½, G 1½ inch (HTHP/HP/C version)
- D. ½ - 14 NPT; optional adapters: M20x1.5, eurofast and minifast
- E. L ≤ 20 ft (6 m)
- F. 1 in., 1½ in.: s52; 2 in.: s60
- G. 1 in.: s52; 1½ in.: s60
- H. NPT: s50; G: s60

Dimensions are in inches (millimeters).

Figure 42: Large Coaxial Probe with Flange Connection

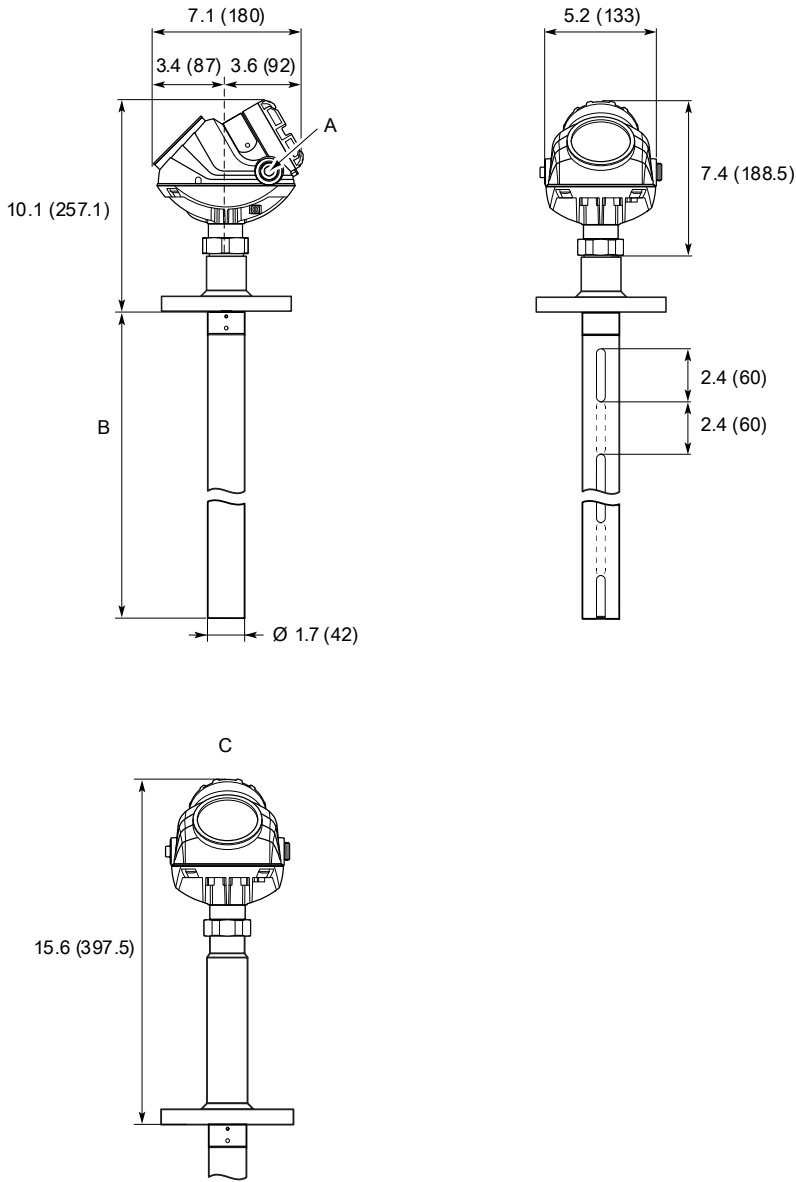

- A. 1/2 - 14 NPT; optional adapters: M20x1.5, eurofast and minifast
- B.  $L \leq 20$  ft. (6 m)
- C. HP/C version

Dimensions are in inches (millimeters).



**Figure 43: Large Coaxial Probe with Threaded Connection**

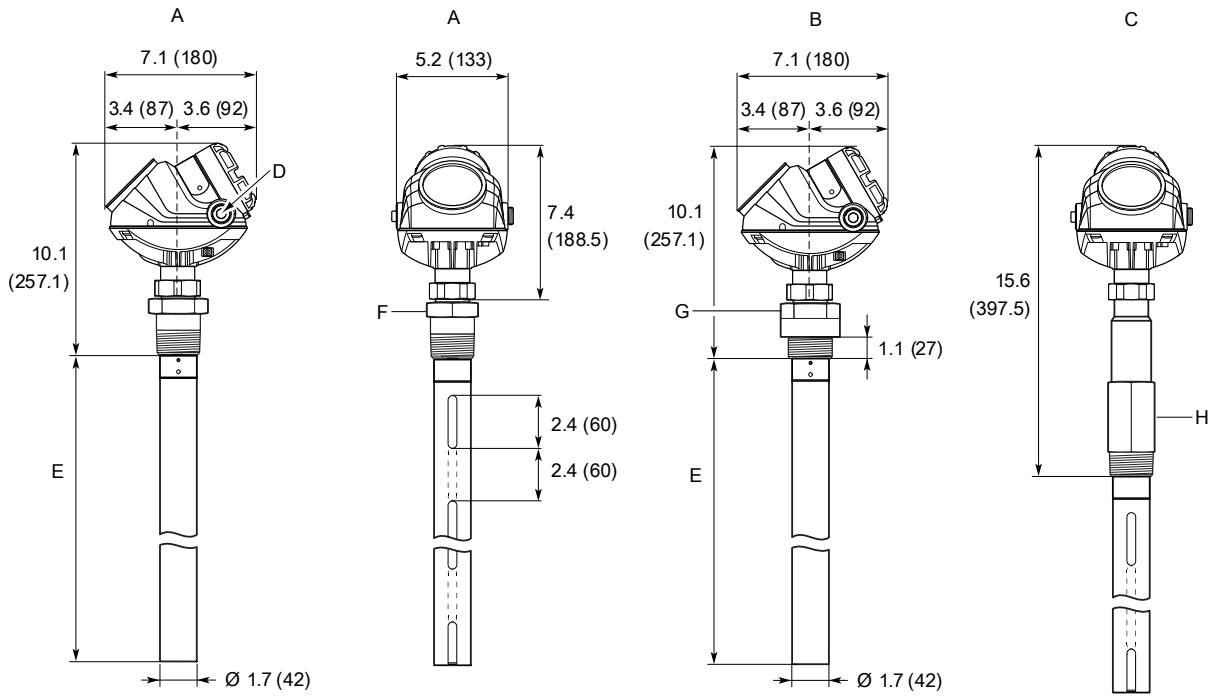

- A. NPT 1½ in.
- B. G 1½ in.
- C. NPT 1½, G 1½ in. (HP/C version)
- D. ½ - 14 NPT; optional adapters: M20x1.5, eurofast and minifast
- E. L ≤ 20 ft. (6 m)
- F. 1½ in.: s52; 2 in.: s60
- G. 1½ in.: s60
- H. NPT: s50; G: s60

Dimensions are in inches (millimeters).

Figure 44: Integrated Still Pipe Vapor Probe for 3-in. Chambers and above

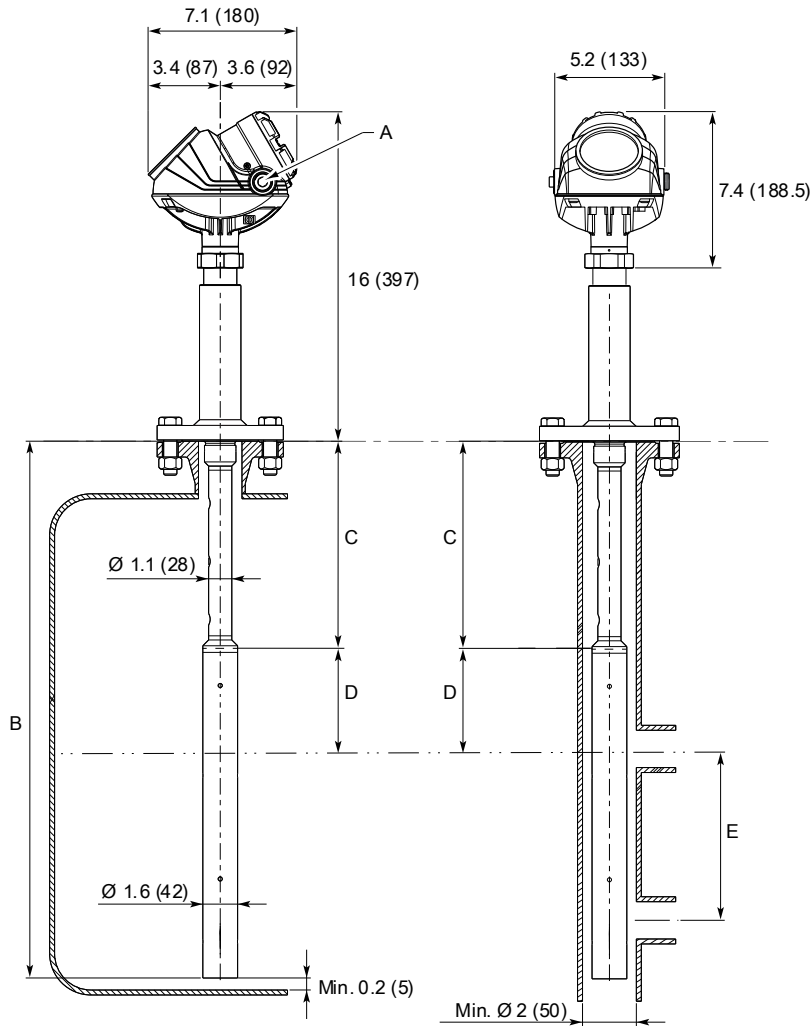

- A. 1/2 - 14 NPT; optional adapters: M20x1.5, eurofast and minifast
- B. L ≤ 13 ft. 1 in. (4 m)
- C. Short reflector: 13.8 (350); Long reflector: 19.7 (500)
- D. Minimum 8.3 in. (210 mm) distance between water surface and reflector end
- E. Minimum 12 in. (300 mm)

Dimensions are in inches (millimeters).

Figure 45: Rigid Twin Lead Probe

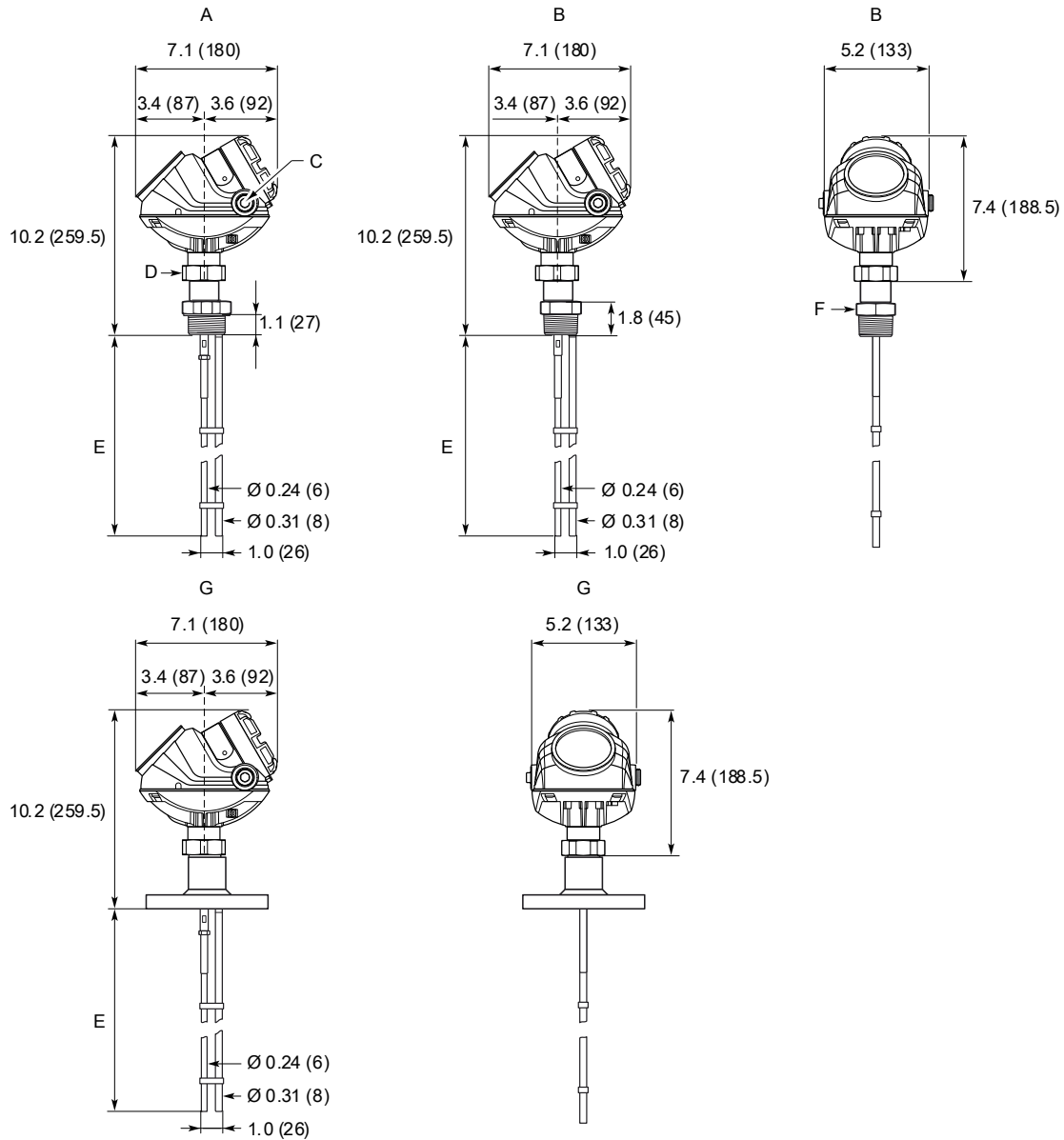

- A.  $G 1\frac{1}{2}$  in.
- B. NPT  $1\frac{1}{2}$  / 2 in.
- C.  $\frac{1}{2}$  - 14 NPT; optional adapters: M20x1.5, eurofast and minifast
- D. s60
- E.  $L \leq 10$  ft. (3 m)
- F.  $1\frac{1}{2}$  in.: s52; 2 in.: s60
- G. Flange

Dimensions are in inches (millimeters).

Figure 46: Flexible Twin Lead Probe

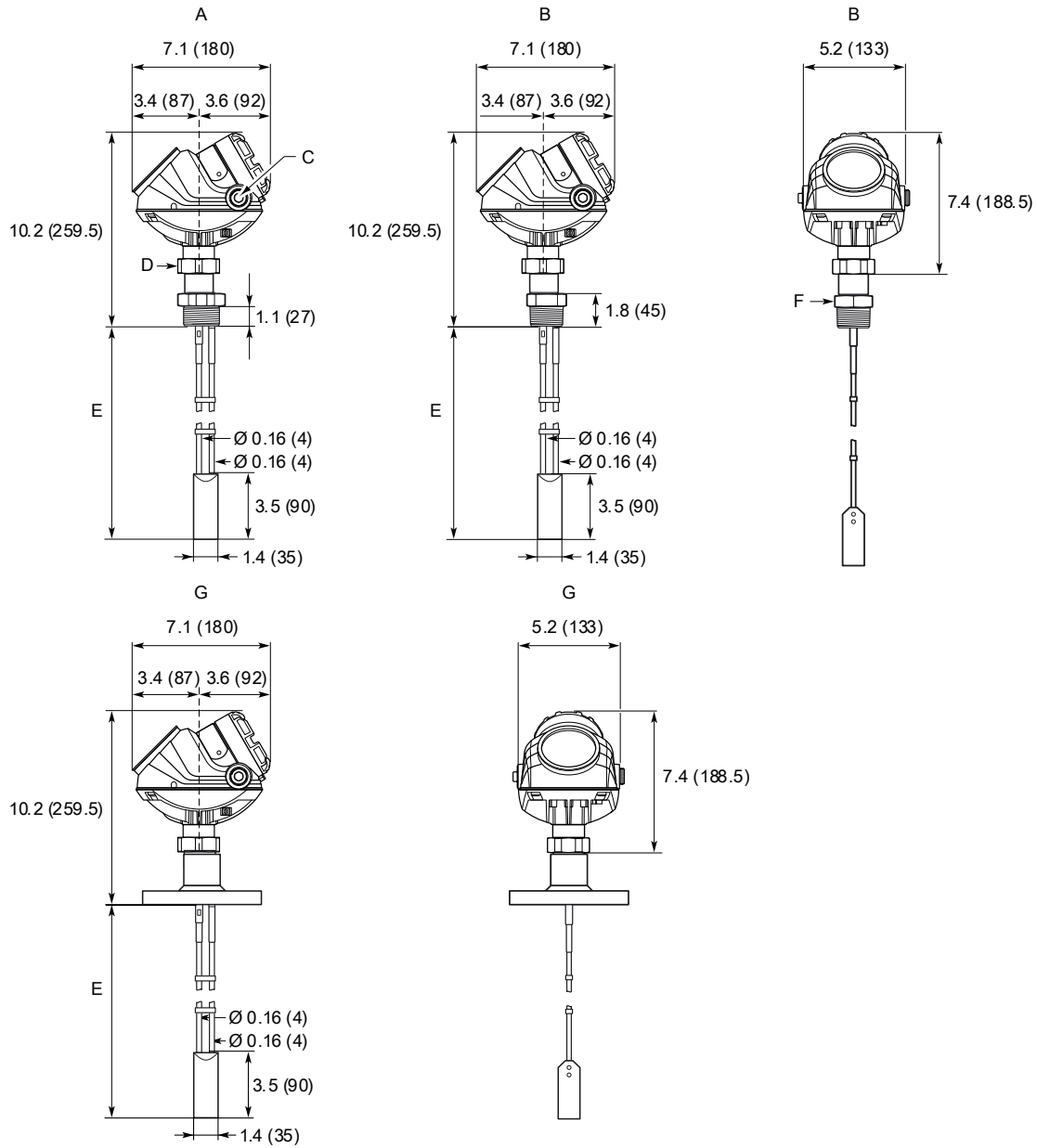

- A. G 1½ in.
- B. NPT 1½ / 2 in.
- C. ½ - 14 NPT; optional adapters: M20x1.5, eurofast and minifast
- D. s60
- E. L ≤ 164 ft. (50 m)
- F. 1½ in.: s52; 2 in.: s60
- G. Flange

Dimensions are in inches (millimeters).

**Figure 47: Mounting Bracket (Option Code BR)**

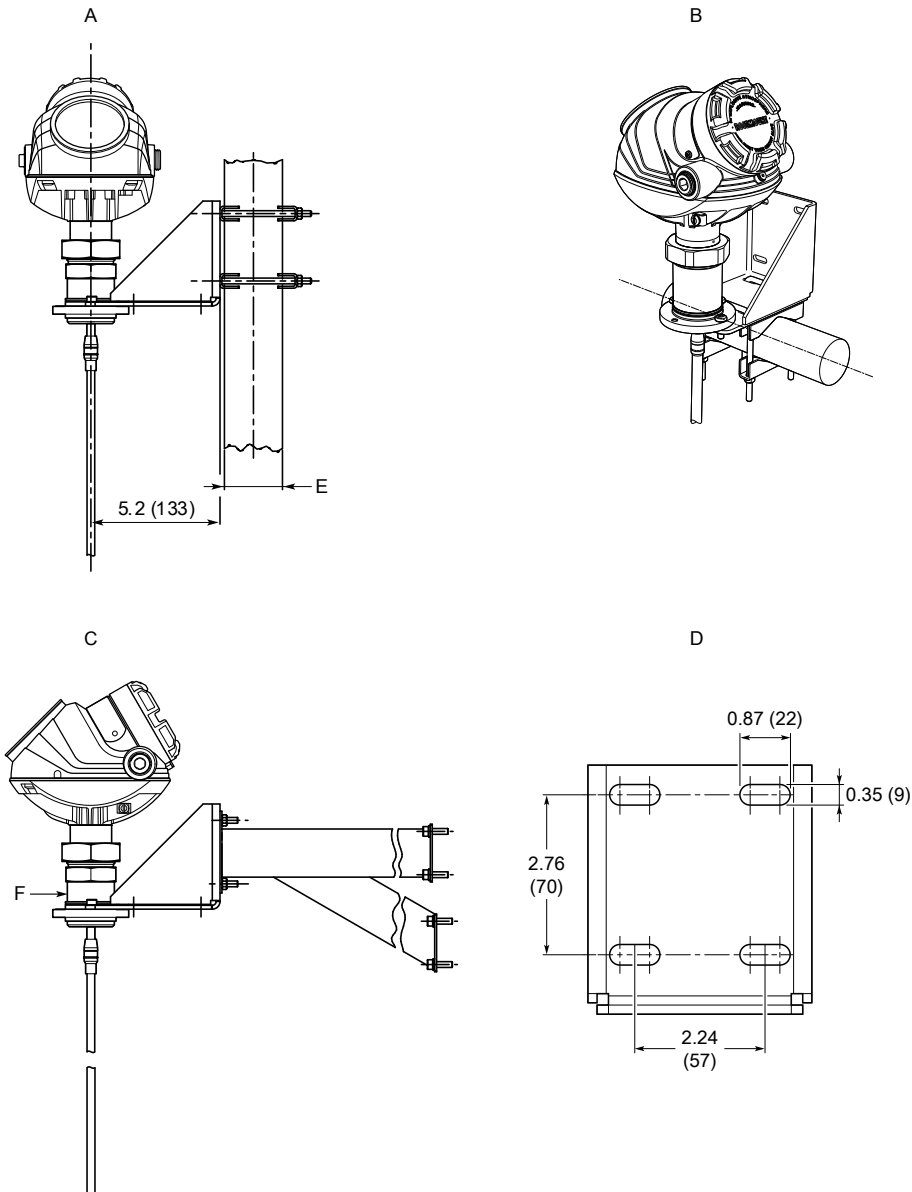

- A. Pipe mounting (vertical pipe)
- B. Pipe mounting (horizontal pipe)
- C. Wall mounting
- D. Hole pattern for wall mounting
- E. Pipe diameter: max 2.5 in. (64 mm)
- F. NPT 1½-in.

Dimensions are in inches (millimeters).

Figure 48: Remote Housing (Option Code B1, B2, B3)

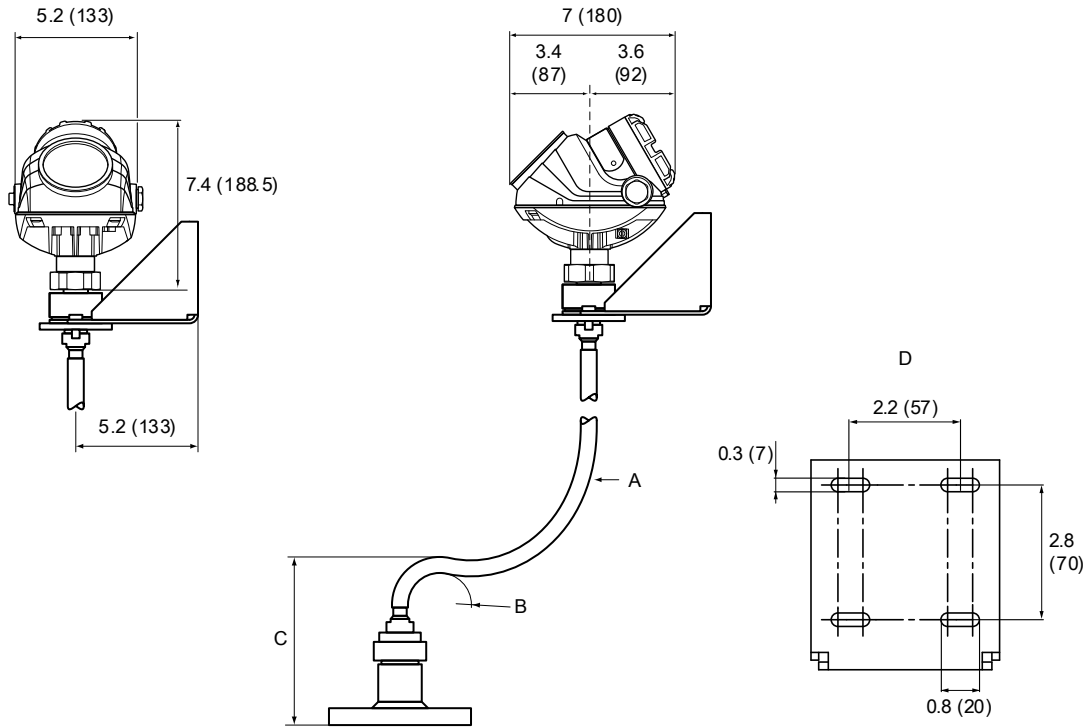

- A. 3, 6, 9 ft. (1, 2, or 3 m)
- B.  $R_{min}$ : 1.4 (35)
- C.  $H_{min}$ : 6.9 (175) for Standard variant; 12.4 (315) for HTHP/HP/C variant
- D. Hole pattern for remote housing wall mounting

Dimensions are in inches (millimeters).

## Proprietary flanges

Figure 49: Proprietary Flanges

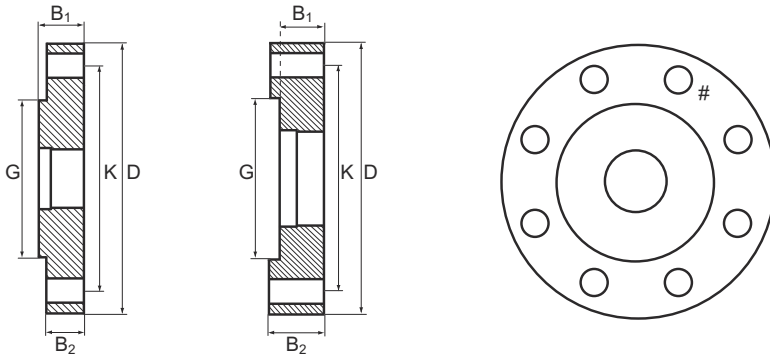

D: Outside diameter

B<sub>1</sub>: Flange thickness with gasket surface

B<sub>2</sub>: Flange thickness without gasket surface

F=B<sub>1</sub>-B<sub>2</sub>: Gasket surface thickness

G: Gasket surface diameter

# Bolts: Number of bolts

K: Bolt hole circle diameter

Dimensions are in inches (millimeters).

### Note

Dimensions may be used to aid in the identification of installed flanges. It is not intended for manufacturing use.

Table 38: Dimensions of Proprietary Flanges

Special flanges <sup>(1)</sup>	D	B <sub>1</sub>	B <sub>2</sub>	F	G	# Bolts	K
Fisher™ 249B/259B <sup>(2)</sup>	9.00 (228.6)	1.50 (38.2)	1.25 (31.8)	0.25 (6.4)	5.23 (132.8)	8	7.25 (184.2)
Fisher 249C <sup>(3)</sup>	5.69 (144.5)	0.94 (23.8)	1.13 (28.6)	-0.19 (-4.8)	3.37 (85.7)	8	4.75 (120.65)
Masoneilan™ <sup>(2)</sup>	7.51(191.0)	1.54 (39.0)	1.30 (33.0)	0.24 (6.0)	4.02 (102.0)	8	5.87 (149.0)

(1) These flanges are also available in a vented version. Vented flanges must be ordered with a 1½-in. NPT threaded process connection (code RA).

(2) Flange with raised face.

(3) Flange with recessed face.

For information about flange temperature and pressure ratings, see [Fisher and Masoneilan flange rating](#).

## Flushing connection rings

Figure 50: Flushing Connection Rings

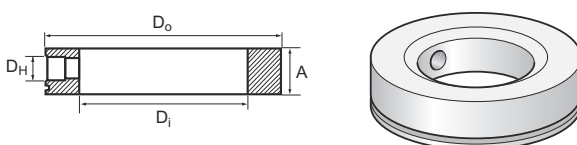

A. Height: 0.97 in. (24.6 mm)

**Table 39: Pressure and Temperature Rating for Flushing Ring up to Class 2500**

Flushing connection rings	D <sub>i</sub>	D <sub>o</sub>	D <sub>H</sub>
2 in. ANSI	2.12 (53.8)	3.62 (91.9)	¼ in. NPT
3 in. ANSI	3.60 (91.4)	5.00 (127.0)	¼ in. NPT
4 in. ANSI/DN100	3.60 (91.4)	6.20 (157.5)	¼ in. NPT
DN50	2.40 (61.0)	4.00 (102.0)	¼ in. NPT
DN80	3.60 (91.4)	5.43 (138.0)	¼ in. NPT









#### Global Headquarters

Emerson Automation Solutions  
6021 Innovation Blvd.  
Shakopee, MN 55379, USA

📞 +1 800 999 9307 or +1 952 906 8888  
☎️ +1 952 204 8889  
✉️ RFQ.RMD-RCC@Emerson.com

#### North America Regional Office

Emerson Automation Solutions  
8200 Market Blvd.  
Chanhassen, MN 55317, USA

📞 +1 800 999 9307 or +1 952 906 8888  
☎️ +1 952 204 8889  
✉️ RMT-NA.RCCRFQ@Emerson.com

#### Latin America Regional Office

Emerson Automation Solutions  
1300 Concord Terrace, Suite 400  
Sunrise, FL 33323, USA

📞 +1 954 846 5030  
☎️ +1 954 846 5121  
✉️ RFQ.RMD-RCC@Emerson.com

#### Europe Regional Office

Emerson Automation Solutions Europe  
GmbH  
Neuhofstrasse 19a P.O. Box 1046  
CH 6340 Baar  
Switzerland

📞 +41 (0) 41 768 6111  
☎️ +41 (0) 41 768 6300  
✉️ RFQ.RMD-RCC@Emerson.com

#### Asia Pacific Regional Office

Emerson Automation Solutions  
1 Pandan Crescent  
Singapore 128461

📞 +65 6777 8211  
☎️ +65 6777 0947  
✉️ Enquiries@AP.Emerson.com

#### Middle East and Africa Regional Office

Emerson Automation Solutions  
Emerson FZE P.O. Box 17033  
Jebel Ali Free Zone - South 2  
Dubai, United Arab Emirates

📞 +971 4 8118100  
☎️ +971 4 8865465  
✉️ RFQ.RMTMEA@Emerson.com

 [Linkedin.com/company/Emerson-Automation-Solutions](https://www.linkedin.com/company/Emerson-Automation-Solutions)

 [Twitter.com/Rosemount\\_News](https://twitter.com/Rosemount_News)

 [Facebook.com/Rosemount](https://www.facebook.com/Rosemount)

 [Youtube.com/user/RosemountMeasurement](https://www.youtube.com/user/RosemountMeasurement)

©2019 Emerson. All rights reserved.

Emerson Terms and Conditions of Sale are available upon request. The Emerson logo is a trademark and service mark of Emerson Electric Co. Rosemount is a mark of one of the Emerson family of companies. All other marks are the property of their respective owners.