

# Type Y692 Gas Blanketing Regulator System



W5930-1

*Figure 1. Type Y692 Low-Pressure Gas Blanketing Regulator*

## Introduction

An Accu-Pressure™ Gas Blanketing Regulator System reduces a high-pressure gas, such as Nitrogen, to maintain a protective environment above any liquid stored in a tank or vessel when the liquid is being pumped out. Also when the vessel is suddenly cooled, causing vapors inside the vessel to contract, the regulator system replaces the volume of contracting vapors with a volume of blanketing gas to prevent the internal vessel pressure from decreasing. In both cases, a slight positive vessel pressure prevents outside air, moisture and other contaminants from entering the vessel and the possible collapse of the vessel walls.

The Type Y692 (Figure 1) is a direct-operated regulator used for accurate pressure control on very low-pressure blanketing systems. Downstream pressure is sensed through a pitot tube installed in the lower casing of the regulator for units with internal pressure registration or through a downstream control line for units with external pressure registration. The Type Y692 is available in NPS 1-1/2 and 2 (DN 40 and 50) body sizes.

## Features

- **Ease of Inspection and Maintenance**—The union nut connection between the body and actuator permits access to the disk and orifice by only removing the diaphragm casing assembly without removing the body from the line.
- **Accuracy of Control**—Large diaphragm areas provide more precise control even at low-pressure settings and the pitot tube also creates a dynamic boost that helps provide greater capacity.
- **Speed of Response**—The downstream pressure is sensed directly by the diaphragm through the pitot tube providing quick response.
- **Ease of Installation**—The Type Y692 is easy to install in the pipeline because no additional connections are required.



## Specifications

### Available Configurations

Direct-operated pressure reducing regulator with external or internal pressure registration with seven outlet (control) pressure ranges from 1-inch w.c. to 7 psig (2 mbar to 0,48 bar). Available in NPS 1-1/2 and 2 (DN 40 and 50) body sizes.

### Body Sizes and End Connection Styles<sup>(1)</sup>

**Cast Iron:** NPS 1-1/2 (DN 40), NPT NPS 2 (DN 50), NPT or CL125 FF

**Steel:** NPS 1-1/2 or 2 (DN 40 or 50), NPT, SWE, CL150 RF, CL300 RF, or PN 16/25/40

**Stainless Steel:** NPS 1-1/2 or 2 (DN 40 or 50), NPT, CL150 RF, CL300 RF, or PN 16/25/40

### Maximum Inlet Pressure<sup>(2)</sup>

150 psig (10,3 bar)

### Maximum Outlet (Casing) Pressure<sup>(2)</sup>

15 psig (1,0 bar)

### Maximum Operating Outlet (Control) Pressure to Avoid Internal Part Damage<sup>(2)</sup>

3 psig (0,21 bar) above outlet (control) pressure setting

### Control Pressure Ranges<sup>(2)</sup>

See Table 1

### Flow Capacities

See Table 5

### Relief Sizing Coefficients

See Table 6

### Orifice Size

See Table 6

### Pressure Registration

Internal (**standard**) or External

### Spring Case Connection

1/4 NPT

### Temperature Capabilities<sup>(2)</sup>

#### Nitrile (NBR):

-20° to 180°F (-29° to 82°C)

#### Fluorocarbon (FKM):

0° to 300°F (-18° to 149°C)

#### Perfluoroelastomer (FFKM):

-20° to 300°F (-29° to 149°C)

#### EthylenePropylene (EPDM):

-20° to 275°F (-29° to 135°C)

### IEC Sizing Coefficients

$X_T$ : 0.775

$F_D$ : 0.50

$F_L$ : 0.89

### Approximate Weights

**Cast Iron Body:** 45 pounds (20 kg)

**Steel /Stainless Steel Body:** 57 pounds (26 kg)

### Canadian Registration Number (CRN)

Approved

### PED (Pressure Equipment Directive) Category

The Type Y692 may be used as a safety accessory with pressure equipment in the PED 97/23/EC category I.

### Construction Materials

#### Body, Union Nut, Spring Case, and Lower

**Casing Assembly:** Cast iron, WCC Steel, CF8M stainless steel

**Control Spring, Control Spring Seat, Split Ring, and Diaphragm Plate:** Plated steel

**Diaphragm:** Nitrile (NBR) (**standard**), Fluorocarbon (FKM), Ethylenepropylene (EPDM), Silicone (VMQ)

**O-Rings:** Nitrile (NBR), Fluorocarbon (FKM), Perfluoroelastomer (FFKM), Ethylenepropylene (EPDM)

**Orifice, Pusher Post, Pusher Post Connector, Lever Assembly, Stem, and Pitot Tube:**

Stainless steel

**Gasket:** Composition

**Disk Assembly:** Nitrile (NBR) and stainless steel, Fluorocarbon (FKM) and stainless steel, Polytetrafluoroethylene (PTFE) and stainless steel or Ethylenepropylene (EPDM) and stainless steel

1. Fabricated by using slip-on flanges and socket welding nipples into body.

2. The pressure/temperature limits in this bulletin and any applicable standard limitation should not be exceeded.

**Table 1. Control Pressure Ranges**

CONTROL PRESSURE RANGES WITH CASE BARREL POINTED DOWN		CONTROL SPRING COLOR CODE	CONTROL SPRING PART NUMBER	SPRING WIRE DIAMETER, INCHES (mm)	SPRING ZFREE LENGTH, INCHES (mm)
Light Spring Assembly	1 to 3-inches w.c. (2 to 7 mbar) <sup>(2)(3)</sup>	Brown	1D892527022	0.109 (2,77)	6.12 (155)
	3 to 11-inches w.c. (7 to 27 mbar) <sup>(2)(4)</sup>	Iridite	0B019727052	0.148 (3,76)	6.00 (152)
	6.5-inches w.c. to 1.2 psig (16 mbar to 0,08 bar) <sup>(5)</sup>	Green	0B019427052	0.187 (4,75)	6.00 (152)
	0.7 to 2 psig (0,05 to 0,14 bar)	Blue	0B019627032	0.225 (5,71)	6.00 (152)
	1 to 3.2 psig (0,07 to 0,22 bar)	Orange	0A081127202	0.250 (6,35)	6.00 (152)
Heavy spring Assembly	2 to 5.5 psig (0,14 to 0,38 bar)	Metallic with green stripe	0Y066427022	0.363 (9,22)	6.00 (152)
	4 to 7 psig (0,28 to 0,48 bar)	Metallic (silver)	1H802427032	0.406 (10,3)	6.00 (152)

1. Install with spring case pointing down to achieve low setpoints in these spring ranges.  
 2. Do not use fluorocarbon (FKM) diaphragm with these springs at diaphragm temperature lower than 60°F (16°C).  
 3. Ins tallation with spring case pointing up will change outlet (control) pressure range to 3 to 5-inches w.c. (7 to 12 mbar).  
 4. Installation with spring case pointing up will change outlet (control) pressure range to 5.75 to 14-inches w.c. (14 to 35 mbar).  
 5. Installation with spring case pointing up will change outlet (control) pressure range to 7.5 inches w.c. to 1.3 psig (19 to 90 mbar).

**Table 2. Flow Rate Conversion<sup>(1)</sup>**

MULTIPLY MAXIMUM PUMP RATE OUT:	BY	TO OBTAIN
U.S. GPM	8.021	SCFH
U.S. GPH	0.1337	SCFH
m <sup>3</sup> /hr	1.01	NM <sup>3</sup> /H
Barrels/hr	5.615	SCFH
Barrels/day	0.2340	SCFH

1. Gas flow of blanketing gas to replace liquid pumped out.

**Table 3. Conversion Factors (for converting Nitrogen flow rates to other gas flow rates)**

BLANKET GAS	SPECIFIC GRAVITY	CORRECTION FACTOR
Natural Gas	0.60	1.270
Air	1.00	0.985
Dry CO <sub>2</sub>	1.52	0.797

Correction Factor =  $\frac{0.985}{\sqrt{SG}}$

**Table 4. Gas Flow Required for Thermal Heating (Outbreathing) or Cooling (Inbreathing) per API 2000 (Interpolate for Intermediate size)**

VESSEL CAPACITY			SCFH (Nm <sup>3</sup> /h) AIR FLOW RATE REQUIRED
Barrels	Gallons	Liters	
60	2500	9500	60 (1,6)
100	4200	16 000	100 (2,7)
500	21,000	79 500	500 (1,3)
1000	42,000	159 000	1000 (26,8)
2000	84,000	318 000	2000 (53,6)
3000	126,000	477 000	3000 (80,4)
4000	168,000	636 000	4000 (107)
5000	210,000	795 000	5000 (134)
10,000	420,000	1 590 000	10 000 (268)
15,000	630,000	2 385 000	15 000 (402)
20,000	840,000	3 180 000	20 000 (536)
25,000	1,050,000	3 975 000	24 000 (643)
30,000	1,260,000	4 769 000	28 000 (750)
35,000	1,470,000	5 564 000	31 000 (831)
40,000	1,680,000	6 359 000	34 000 (911)
45,000	1,890,000	7 154 000	37 000 (992)
50,000	2,100,000	7 949 000	40 000 (1072)
60,000	2,520,000	9 539 000	44 000 (1179)
70,000	2,940,000	11 129 000	48 000 (1286)
80,000	3,360,000	12 718 000	52 000 (1394)
90,000	3,780,000	14 308 000	56 000 (1501)
100,000	4,200,000	15 898 000	60 000 (1608)
120,000	5,040,000	19 078 000	68 000 (1822)
140,000	5,880,000	22 437 000	75 000 (2010)
160,000	6,720,000	25 437 000	82 000 (2198)
180,000	7,560,000	28 616 000	90 000 (2412)

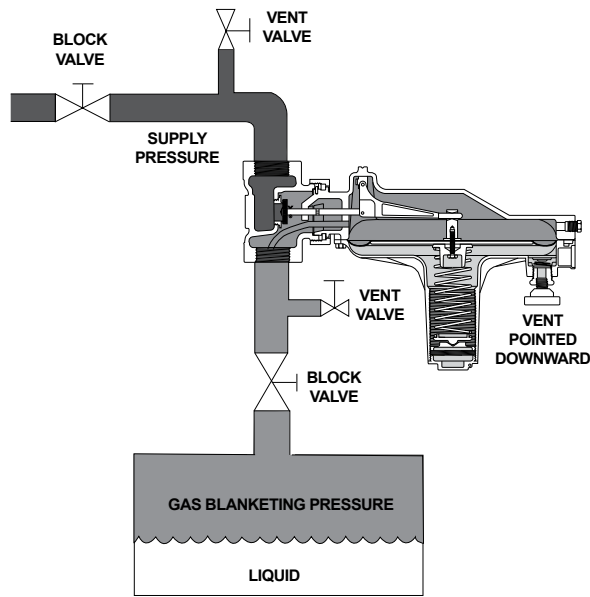

TYPE Y692 WITH INTERNAL REGISTRATION

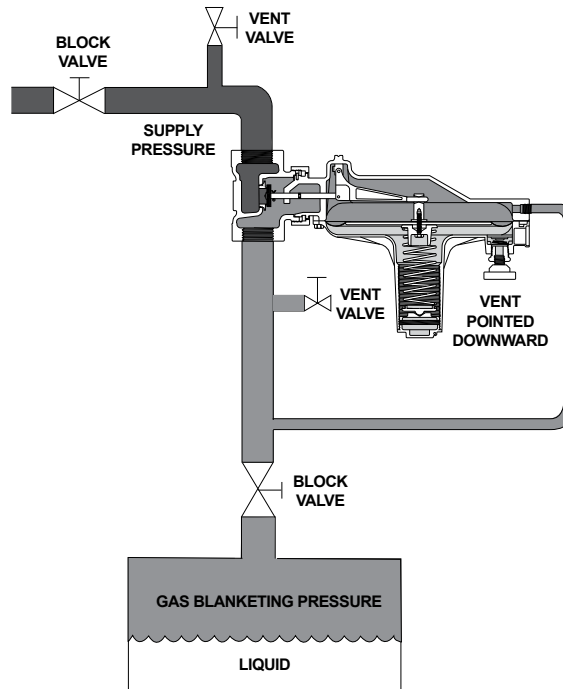

TYPE Y692 WITH EXTERNAL REGISTRATION

- INLET PRESSURE
- CONTROL PRESSURE (OUTLET PRESSURE)
- ATMOSPHERIC PRESSURE

A6340

Figure 2. Type Y692 Operational Schematics

## Principle of Operation

The Type Y692 Gas Blanketing Regulator reduces a high-pressure gas to maintain a positive low-pressure of blanket gas over a stored liquid when the liquid is being pumped out of the vessel (see Figure 2). Also when the vessel (or tank) is suddenly cooled, causing vapors to contract, the regulator replaces the volume of contracting vapors with a volume of blanketing gas to prevent the internal vessel pressure from decreasing. In both cases, a positive vessel pressure prevents outside air from entering the vessel and reduces the possibility of atmospheric pressure collapsing the vessel.

Gas blanketing regulators respond to a slight decrease in internal vessel pressure by throttling open to increase the flow rate of gas into the vessel. When the vessel's liquid level has been lowered to the desired point and the vapor pressure re-established, the regulator throttles closed.

When the liquid level drops and vessel pressure decreases below the setting of the control spring, the spring force on the diaphragm opens the disk assembly to supply the required flow of gas to the vessel. When vessel pressure has been satisfied, control pressure tends to increase slightly, acting on the diaphragm. When the control (vessel) pressure exceeds the control spring setting, the diaphragm moves to close the disk assembly.

The Type Y692 Gas Blanketing Regulator provides a constant set pressure for accurate gas blanketing. When vessel pressure decreases below the control spring setpoint, the force of the spring moves the disk away from the orifice allowing gas to flow into the vessel. As the vessel pressure increases, the increase is sensed by the diaphragm through the pitot tube or control line. This movement of the diaphragm causes

the disk to move toward the orifice, decreasing the flow of blanketing gas. When the vessel pressure reaches the system setpoint, the disk will seat against the orifice shutting off the flow of gas.

## Installation

Install the Type Y692 regulator with the spring case barrel pointed down. This will assure that the lowest set pressure shown in Table 1 is achieved. Flow through the regulator body is indicated by the flow arrow cast on the body. If a block valve is required, install a full flow valve between the regulator and the blanketed vessel.

## Sizing Tank Blanketing Systems

When sizing a gas blanketing regulator system for a low pressure blanketing application, you must consider the replacement of blanketing gas required for the liquid loss during pump out of the vessel and also the condensation/contraction of vessel vapors during atmospheric thermal cooling.

## Direct Displacement

The direct displacement method should be used with extreme caution. The direct displacement method determines the amount of blanketing gas required to replace liquid pumped out of the tank. Direct displacement does not allow for fluctuating temperature or other factors that may affect pressure in the vapor space. This method is typically applied to tanks operating at constant temperature and containing non-flammable, non-volatile products.

$$Q_{total} = Q_{pump}$$

where,

$Q_{total}$  = Required Flow Rate

$Q_{pump}$  = Required Flow Rate to replace pumped out liquid from Table 1

## API 2000

The American Petroleum Institute Standard 2000 (API 2000) sizing method accounts for liquid pump-out as well as contraction of tank vapors due to cooling. When using API methods:

$$Q_{\text{total}} = Q_{\text{pump}} + Q_{\text{thermal}}$$

where,

$Q_{\text{total}}$  = Required Flow Rate

$Q_{\text{pump}}$  = Required Flow Rate to replace pumped out liquid from Table 1

$Q_{\text{thermal}}$  = Required Flow Rate due to thermal cooling. See Thermal Equations 1 to 4 below or Table 2.

### Thermal Equations

For tanks up to 840 000 gallons (3179 m<sup>3</sup>) capacity, use one of the following equations:

#### Equation 1:

$$Q_{\text{thermal}} [\text{SCFH Air}] = V_{\text{tank}} \times 0.0238$$

#### Equation 2:

$$Q_{\text{thermal}} [\text{SCFH Nitrogen}] = V_{\text{tank}} \times 0.0238 \times 1.015$$

#### Equation 3:

$$Q_{\text{thermal}} [\text{Nm}^3/\text{h Air}] = V_{\text{tank}} \times 0.169$$

#### Equation 1:

$$Q_{\text{thermal}} [\text{Nm}^3/\text{h Nitrogen}] = V_{\text{tank}} \times 0.169 \times 1.015$$

where,

For Equations 1 and 2:  $V_{\text{tank}}$  = tank volume, gallons

For Equations 3 and 4:  $V_{\text{tank}}$  = tank volume, m<sup>3</sup>

For tanks greater than 840 000 gallons (3179 m<sup>3</sup>) capacity: See Table 2.

Depending on the method, there can be a significant difference in the calculated required capacity. **No matter which method is used, the tank must be equipped with supplemental venting to protect**

**the tank, product, and personnel in cases of equipment failure, fire exposure, or other conditions that could cause the tank pressure or vacuum to exceed operating limits.**

### Sizing can be done by following these steps:

1. Determine the gas flow rate required to replace the liquid being pumped out (see Table 2).
2. Using the established procedures from the American Petroleum Institute Standard 2000 (API 2000), determine the gas flow rate due to "inbreathing" caused by atmospheric thermal cooling (see Table 4).
3. Add the requirements of 1 and 2 and select the regulator size, based on total capacity required from Table 6.

### Sample sizing problem for blanketing applications:

Service Conditions:

Vessel Capacity . . . . . 42 000 gallons (159 000 L)  
 Pump In/Out Capacity . . 150 gallons/minute (570 L/m)  
 Inlet Pressure Source . . . . . 20 psig (1,4 bar) Nitrogen  
 Desired Blanket Setpoint . . . . . 1-inch w.c. (2 mbar)

Sizing and Selection Methodology:

1. From Table 2 the desired air flow rate due to pump out equals 150 GPM x 8.021 = 1203 SCFH (32,2 Nm<sup>3</sup>/h) air.
2. From Table 4, the required air flow due to thermal cooling = 1000 SCFH (26,8 Nm<sup>3</sup>/h) air.
3. Total flow required for pump out and thermal cooling is 1203 + 1000 = 2203 SCFH (59,0 Nm<sup>3</sup>/h) air.
4. Convert to nitrogen by dividing the total air flow by the square root of the specific gravity of nitrogen:  
 $2203 \div 0.97 = 2248 \text{ SCFH (60,2 Nm}^3/\text{h) nitrogen}$   
 (See Table 3 for the conversion).
5. From Table 5, a Type Y692 in either an NPS 1-1/2 and 2 (DN 40 and 50) body sizes and a 3/8-inch (9,5 mm) orifice will flow 3620 SCFH (97,0 Nm<sup>3</sup>/h) nitrogen at 20 psig (1,4 bar) inlet pressure. This satisfies the required flow of 2248 SCFH (60,2 Nm<sup>3</sup>/h) nitrogen.

## Capacity Information

Table 5 gives the typical regulating capacities at selected inlet pressures and outlet (control) pressure settings. Flows are in SCFH (60°F and 14.7 psia) of 0.97 specific gravity nitrogen. For gases of other specific gravities, multiply the given capacity of nitrogen by 0.985, and divide the given capacity by the square root of the appropriate specific gravity of the gas required. Then, if capacity is desired in normal cubic meters per hour at 0°C and 1,01325 bar, multiply SCFH by 0.0268.

To determine wide-open flow capacities for relief sizing, use the following formula:

$$Q = \sqrt{\frac{520}{GT}} C_g P_1 \text{SIN} \left( \frac{3417}{C_1} \sqrt{\frac{\Delta P}{P_1}} \right) \text{DEG}$$

where,

$C_g$  = gas sizing coefficient from Table 6

$C_1 = C_g / C_v$ , or 35 from Table 6

$G$  = gas specific gravity (air = 1.0)

$P_{1\text{abs}}$  = inlet pressure, psia (add 14.7 psi to gauge inlet pressure to obtain absolute inlet pressure)

$Q$  = flow rate, SCFH

$T$  = absolute temperature in °Rankine of gas at inlet

## Ordering Information



When ordering, specify:

1. Type of gas being controlled (nitrogen fuel gas, etc.); list any factors such as impurities in the gas that may affect compatibility of the gas with the regulator trim parts.
2. Specific gravity of the gas
3. Temperature of the gas
4. Range of flowing inlet pressures to regulator
5. Flow rates
  - a) Minimum controlled flow
  - b) Normal flow
  - c) Maximum flow
6. Line size and end connection size of adjacent piping. Adjacent downstream piping must be the same size as the regulator body or longer.
7. Vessel size

# Bulletin 74.1:Y692

**Table 5. Blanketing Regulating Capacities in SCFH (Nm<sup>3</sup>/h) of 0.97 Specific Gravity Nitrogen**

BODY SIZE, NPS (DN)	OUTLET PRESSURE RANGE <sup>(1)</sup> , ACCURACY, AND SPRING COLOR	OUTLET PRESSURE SETTING	INLET PRESSURE, PSIG (bar)	ORIFICE SIZE, INCHES (mm)					
				1/4 (6,4)	3/8 (9,5)	1/2 (13)	3/4 (19)	1 (25)	1-3/16 (30)
1-1/2 (40)	1 to 3-inches w.c. (2 to 7 mbar)  -1 to 2-inches w.c. (-2 to 5 mbar)  Brown	1-inch w.c. (2 mbar)	2 (0,14)	360 (9,7)	970 (26,0)	1750 (46,9)	3280 (87,9)	4750 (127)	3650 (97,8)
			5 (0,34)	680 (18,2)	1560 (41,8)	2800 (75,0)	3880 (104)	3650 (97,8)	
			10 (0,69)	1030 (27,6)	2350 (63,0)	4210 (113)	3880 (104)	3650 (97,8)	
			20 (1,4)	1580 (42,3)	3620 (97,0)	4900 (131)	3700 (99,2)		
			40 (2,8)	2500 (67,0)	3620 (97,0)	4900 (131)			
			60 (4,1)	3410 (91,0)	3620 (97,0)				
	80 (5,5)	4320 (116)							
	100 (6,9)	4510 (121)							
	125 (8,6)	4510 (121)							
	150 (10,3)	4510 (121)							
	2 (0,14)	360 (9,7)	970 (26,0)	1750 (46,9)	3280 (87,9)	4750 (127)	3650 (97,8)	3650 (97,8)	
	5 (0,34)	680 (18,2)	1560 (41,8)	2800 (75,0)	3880 (104)	3650 (97,8)	2840 (76,1)		
10 (0,69)	1030 (27,6)	2350 (63,0)	4210 (113)	3880 (104)	3650 (97,8)				
20 (1,4)	1580 (42,3)	3620 (97,0)	4900 (131)	3700 (99,2)					
40 (2,8)	2500 (67,0)	3620 (97,0)							
60 (4,1)	3410 (91,4)	3620 (97,0)							
80 (5,5)	4320 (116)								
100 (6,9)	4510 (121)								
125 (8,6)	4510 (121)								
150 (10,3)	4510 (121)								
3 to 11-inches w.c. (7 to 27 mbar)  -1 to 2-inches w.c. (-2 to 5 mbar)  Iridite	7-inches w.c. (17 mbar)	0,5 (0,03)				950 (25,5)	1180 (31,6)	1330 (35,6)	
		1 (0,07)	330 (8,8)	630 (16,9)	870 (23,3)	1340 (35,9)	1810 (48,5)	2290 (61,4)	
		2 (0,14)	470 (12,6)	950 (25,5)	1300 (34,8)	2260 (60,6)	3160 (84,7)	4730 (127)	
		5 (0,34)	770 (20,6)	1580 (42,3)	2520 (67,5)	6070 (163)	6100 (163)	6100 (163)	
		13 (0,9)	1270 (34,0)	2590 (69,4)	4900 (131)	6100 (163)	6100 (163)		
		25 (1,7)	1850 (49,6)	6100 (163)	6100 (163)				
50 (3,4)	3040 (81,5)	6100 (163)							
100 (6,9)	5370 (144)	6100 (163)							
150 (10,3)	6100 (163)								
6.5-inches w.c to 1.2 psig (16 mbar to 0,08 bar) Green or 0.7 to 2 psig (0,05 to 0,14 bar) Blue  0.2 psig (0,01 bar)	1.5 psig (0,10 bar)	2 (0,14)		789 (21,1)	1260 (33,8)	2050 (54,9)	2660 (71,3)	3220 (86,3)	
		6 (0,41)		1740 (46,6)	2760 (74,0)	4730 (127)	9790 (182)	7530 (202)	
		14 (0,97)		3156 (84,6)	5050 (121)	9470 (254)	12,500 (335)		
		30 (2,1)		4890 (131)	8050 (216)	13,360 (358)			
		50 (3,4)		7120 (191)	11,990 (321)				
		150 (10,3)		18,030 (483)					
1 to 3.2 psig (0,07 to 0,22 bar)  0.6 psig (0,04 mbar)  Orange	3 psig (0,21 bar)	3 (0,21)					2450 (64,7)	2840 (76,1)	
		7 (0,48)		1550 (41,5)	2370 (63,5)	3950 (106)	5130 (137)	6312 (169)	
		14 (0,97)		2370 (63,5)	3700 (99,2)	7020 (188)	7470 (200)		
		30 (2,1)		4500 (121)	7380 (198)	11,680 (313)			
		50 (3,4)		7020 (188)	10,750 (288)				
		150 (10,3)		17,250 (462)					
2 to 5.5 psig (0,14 to 0,38 bar)  0.5 psig (0,03 bar)  Silver with green stripe	5 psig (0,34 bar)	2 (0,14)	360 (9,7)	970 (26,0)	1750 (46,9)	3280 (87,9)	4750 (127)	3650 (97,8)	
		10 (0,69)	590 (15,8)	950 (25,5)	1180 (31,6)	1810 (48,5)	2200 (59,0)	2370 (63,5)	
		15 (1,0)	789 (21,1)	1030 (27,6)	1580 (42,3)	2370 (63,5)	2840 (76,1)	3310 (88,7)	
		20 (1,4)	950 (25,5)	1380 (97,0)	2200 (59,0)	2920 (78,3)	3310 (88,7)		
		35 (2,4)	1420 (38,1)	1970 (52,8)	2920 (78,3)	4020 (108)			
		60 (4,1)	2210 (59,2)	2920 (78,3)	4730 (127)				
75 (5,2)	2760 (74,0)	3470 (93,0)	5680 (152)						
100 (6,9)	3550 (95,1)	5130 (137)							
2 to 5.5 psig (0,14 to 0,38 bar)  1 psig (0,07 bar)  Silver with green stripe	5 psig (0,34 bar)	10 (0,69)	950 (25,5)	1500 (40,2)	2050 (54,9)	3230 (86,6)	4100 (110)	4580 (123)	
		15 (1,0)	1180 (31,6)	1890 (50,7)	2760 (74,0)	4100 (110)	5520 (148)	6310 (169)	
		20 (1,4)	1380 (37,0)	2200 (59,0)	3790 (102)	5130 (137)	6310 (169)		
		35 (2,4)	1970 (52,8)	3310 (88,7)	5130 (137)	7730 (207)			
		60 (4,1)	3160 (84,7)	5290 (142)	7890 (211)				
		75 (5,2)	4100 (110)	6390 (171)	10,260 (275)				
100 (6,9)	5130 (137)	8680 (233)							
4 to 10 psig (0,28 to 0,69 bar)  1 psig (0,07 bar)  Silver	10 psig (0,69 bar)	15 (1,0)	708 (19,0)	1023 (27,4)	1338 (35,9)	1810 (48,5)	2518 (67,5)	2990 (80,1)	
		20 (1,4)	944 (25,3)	1377 (36,9)	1967 (52,7)	2597 (69,9)	3148 (84,4)	4564 (122)	
		25 (1,7)	1102 (29,5)	1652 (44,3)	2203 (59,0)	3148 (84,4)	4013 (108)		
		40 (2,8)	1810 (48,5)	2203 (59,0)	2912 (78,0)	4720 (127)			
		60 (4,1)	2361 (63,3)	3148 (84,4)	4643 (124)				
		75 (5,2)	2754 (73,8)	3541 (94,9)	5666 (152)				
100 (6,9)	3541 (94,9)	5193 (139)							
4 to 10 psig (0,28 to 0,69 bar)  2 psig (0,14 bar)  Silver	10 psig (0,69 bar)	15 (1,0)	1023 (27,4)	1731 (46,4)	2518 (67,5)	3620 (97,0)	4721 (127)	6295 (169)	
		20 (1,4)	1259 (33,7)	2125 (57,0)	3384 (90,7)	5115 (137)	6295 (169)	7869 (211)	
		25 (1,7)	1574 (42,2)	2675 (71,7)	3777 (101)	6453 (173)	7082 (190)		
		40 (2,8)	2282 (61,2)	3934 (105)	5272 (141)	8656 (232)			
		60 (4,1)	2990 (80,1)	5351 (143)	8656 (232)				
		75 (5,2)	4013 (108)	6531 (175)	10,230 (274)				
100 (6,9)	5115 (137)	8656 (232)							



1. Spring ranges based on regulator installation with the spring case pointed down.  
 - Light shaded areas show where indicated droop would be exceeded regardless of capacity.  
 - Dark shaded areas show where maximum operating inlet pressure for a given orifice size is exceeded.

- continued -



**Table 5. Blanketing Regulating Capacities in SCFH (Nm<sup>3</sup>/h) of 0.97 Specific Gravity Nitrogen (continued)**

BODY SIZE, NPS (DN)	OUTLET PRESSURE RANGE <sup>(1)</sup> , ACCURACY, AND SPRING COLOR	OUTLET PRESSURE SETTING	INLET PRESSURE, PSIG (bar)	ORIFICE SIZE, INCHES (mm)					
				1/4 (6,4)	3/8 (9,5)	1/2 (13)	3/4 (19)	1 (25)	1-3/16 (30)
2 (50)	1 to 3-inches w.c. (2 to 7 mbar)	1-inch w.c. (2 mbar)	2 (0,14)	320 (8,6)	930 (24,9)	1750 (46,9)	4000 (107)	5010 (134)	5930 (159)
			5 (0,34)	680 (18,2)	1560 (41,8)	2800 (75,0)	4630 (124)	4260 (114)	
	-1 to 2-inches w.c. (-2 to 5 mbar)	Brown	10 (0,69)	1030 (27,6)	2350 (63,0)	4210 (113)	3650 (97,8)	4060 (109)	
			20 (1,4)	1580 (42,3)	3620 (97,0)	3450 (92,5)			
			40 (2,8)	2500 (67,0)	4420 (118)				
			60 (4,1)	3410 (91,4)					
			80 (5,5)	3650 (97,8)					
			100 (6,9)	3650 (97,8)					
	3 to 11-inches w.c. (7 to 27 mbar)	3-inches w.c. (7 mbar)	2 (0,14)	320 (8,6)	930 (24,9)	1750 (46,9)	4000 (107)	5010 (134)	5930 (159)
			5 (0,34)	680 (18,2)	1560 (41,8)	2800 (75,0)	6050 (162)	4630 (124)	4260 (114)
			10 (0,69)	1030 (27,6)	2350 (63,0)	4210 (113)	3650 (97,8)	4060 (109)	
			20 (1,4)	1580 (42,3)	3620 (97,0)	3450 (92,5)			
40 (2,8)			2500 (67,0)	4420 (118)					
60 (4,1)			3410 (97,8)						
-1 to 2-inches w.c. (-2 to 5 mbar)	7-inches w.c. (17 mbar)	0.5 (0,03)	1 (0,07)	330 (8,8)	630 (16,9)	870 (23,3)	950 (25,5)	1180 (31,6)	1330 (36,5)
		2 (0,14)	470 (12,6)	950 (25,5)	1300 (34,8)	2260 (60,6)	3160 (84,7)	4730 (127)	
		5 (0,34)	770 (20,6)	1580 (42,3)	2520 (67,5)	6080 (163)	7890 (211)	7890 (211)	
		13 (0,90)	1270 (34,0)	2590 (69,4)	4900 (131)	7890 (211)			
		25 (1,7)	1850 (49,6)	4100 (110)	7180 (192)				
		50 (3,4)	3040 (81,5)	6700 (180)	7890 (211)				
6.5-inches w.c to 1.2 psig (16 mbar to 0,08 bar) Green or 0.7 to 2 psig (0,05 to 0,14 bar) Blue	1 psig (0,07 bar)	2 (0,14)	6 (0,41)	1030 (27,6)	1340 (35,9)	2840 (76,1)	5680 (152)	3230 (86,6)	3390 (90,9)
		14 (0,97)	3390 (90,9)	5130 (137)	8130 (218)	13,490 (362)	8760 (235)		
		30 (2,1)	5130 (137)	7120 (191)	11,990 (321)				
		50 (3,4)	7120 (191)	11,990 (321)	18,310 (491)				
		150 (10,3)							
		0.2 psig (0,01 bar)							
1 to 3.2 psig (0,07 to 0,22 bar)	3 psig (0,21 bar)	3 (0,21)	7 (0,48)		1740 (46,6)	2600 (69,7)	4730 (127)	2550 (68,3)	3050 (81,7)
		14 (0,97)	30 (2,1)		3310 (88,7)	4180 (112)	770 (206)	5880 (158)	7140 (191)
		30 (2,1)	50 (3,4)		5130 (137)	7930 (213)	14,480 (388)	10,450 (280)	
		50 (3,4)	150 (10,3)		7500 (201)	11,400 (306)			
		19,820 (531)							
		Orange							
2 to 5.5 psig (0,14 to 0,38 bar)	5 psig (0,34 bar)	10 (0,69)	15 (1,0)	590 (15,8)	950 (25,5)	1180 (31,6)	1810 (48,5)	2200 (59,0)	2370 (63,5)
		20 (1,4)	789 (21,1)	1030 (27,6)	1580 (42,3)	2370 (63,5)	2840 (76,1)	2840 (76,1)	3310 (88,7)
		35 (2,4)	950 (25,5)	1380 (37,0)	1970 (52,8)	2200 (59,0)	2920 (78,3)	2920 (78,3)	
		60 (4,1)	1420 (38,1)	1970 (52,8)	2920 (78,3)	4730 (127)			
		75 (5,2)	2210 (59,2)	2920 (78,3)	3470 (93,0)	5680 (152)			
		100 (6,9)	2760 (74,0)	3470 (93,0)	5130 (137)				
0.5 psig (0,03 bar)	Silver with green stripe	10 (0,69)	15 (1,0)	590 (15,8)	950 (25,5)	1180 (31,6)	1810 (48,5)	2200 (59,0)	2370 (63,5)
		20 (1,4)	789 (21,1)	1030 (27,6)	1580 (42,3)	2370 (63,5)	2840 (76,1)	2840 (76,1)	3310 (88,7)
		35 (2,4)	950 (25,5)	1380 (37,0)	1970 (52,8)	2200 (59,0)	2920 (78,3)	2920 (78,3)	
		60 (4,1)	1420 (38,1)	1970 (52,8)	2920 (78,3)	4730 (127)			
		75 (5,2)	2210 (59,2)	2920 (78,3)	3470 (93,0)	5680 (152)			
		100 (6,9)	2760 (74,0)	3470 (93,0)	5130 (137)				
2 to 5.5 psig (0,14 to 0,38 bar)	5 psig (0,34 bar)	10 (0,69)	15 (1,0)	950 (25,5)	1500 (40,2)	2050 (54,9)	4100 (110)	4100 (110)	4580 (123)
		15 (1,0)	1180 (31,6)	1890 (50,7)	2760 (74,0)	5520 (148)	5520 (148)	6310 (169)	
		20 (1,4)	1380 (37,0)	2200 (59,0)	3790 (102)	6310 (169)	6310 (169)		
		35 (2,4)	1970 (52,8)	2050 (54,9)	5130 (137)				
		60 (4,1)	3160 (84,7)	5290 (142)	7890 (207)				
		75 (5,2)	4100 (110)	6390 (171)	10,260 (275)				
4 to 10 psig (0,28 to 0,69 bar)	10 psig (0,69 bar)	15 (1,0)	708 (19,0)	1023 (27,4)	1338 (35,9)	2518 (67,5)	2518 (67,5)	2990 (80,1)	
		20 (1,4)	944 (25,3)	1377 (36,9)	1967 (52,7)	3148 (84,4)	3148 (84,4)	4564 (122)	
		25 (1,7)	1102 (29,5)	1652 (44,3)	2203 (59,0)	4013 (108)	4013 (108)		
		40 (2,8)	1810 (48,5)	2675 (71,7)	2912 (78,0)				
		60 (4,1)	2361 (63,3)	3148 (84,4)	4643 (124)				
		75 (5,2)	2754 (73,8)	3541 (94,9)	5666 (152)				
4 to 10 psig (0,28 to 0,69 bar)	10 psig (0,69 bar)	15 (1,0)	1023 (27,4)	1731 (46,4)	2518 (67,5)	4721 (127)	4721 (127)	6295 (169)	
		20 (1,4)	1259 (33,7)	2125 (57,0)	3384 (90,7)	6295 (169)	6295 (169)	7869 (211)	
		25 (1,7)	1574 (42,2)	2675 (71,7)	3777 (101)	7082 (190)	7082 (190)		
		40 (2,8)	2282 (61,2)	3934 (105)	5272 (141)				
		60 (4,1)	2990 (80,1)	5351 (143)	8656 (232)				
		75 (5,2)	4013 (108)	6531 (175)	10,230 (274)				
2 psig (0,14 bar)	Silver	15 (1,0)	1023 (27,4)	1731 (46,4)	2518 (67,5)	4721 (127)	4721 (127)	6295 (169)	
		20 (1,4)	1259 (33,7)	2125 (57,0)	3384 (90,7)	6295 (169)	6295 (169)	7869 (211)	
		25 (1,7)	1574 (42,2)	2675 (71,7)	3777 (101)	7082 (190)	7082 (190)		
		40 (2,8)	2282 (61,2)	3934 (105)	5272 (141)				
		60 (4,1)	2990 (80,1)	5351 (143)	8656 (232)				
		75 (5,2)	4013 (108)	6531 (175)	10,230 (274)				

1. Spring ranges based on regulator installation with the spring case pointed down.  
 - Light shaded areas show where indicated droop would be exceeded regardless of capacity.  
 - Dark shaded areas show where maximum operating inlet pressure for a given orifice size is exceeded.

# Bulletin 74.1:Y692

**Table 6. Orifice Sizes and Coefficients for Relief Valve Sizing**

BODY SIZES, NPS (DN)	ORIFICE SIZE, INCHES (mm)	WIDE-OPEN $C_v$	WIDE-OPEN $C_g$	$C_1$
1-1/2 and 2 (40 and 50)	1/4 (6,4)	1.51	53.0	35
	3/8 (9,5)	3.14	111.0	
	1/2 (13)	5.43	190.0	
	3/4 (19)	11.9	415.0	
	1 (25)	20	700.0	
	1-3/16 (30)	26	910.0	

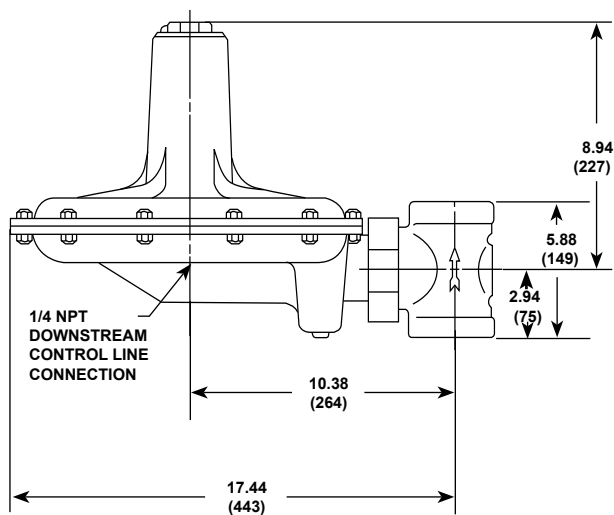

**NPT DIMENSIONS**

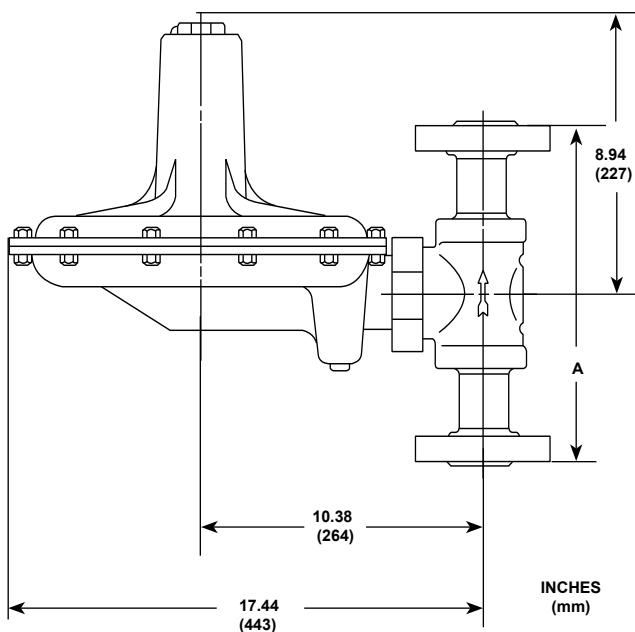

A - CAST IRON FLANGES ARE 10-INCHES (254 mm) FACE-TO-FACE;  
STEEL, STAINLESS STEEL, AND HASTELLOY C FLANGES  
ARE 14-INCHES (356 mm) FACE-TO-FACE.

**FLANGED DIMENSIONS**

**Figure 3. Dimensions**

## Ordering Guide

Carefully review the Specifications section, then specify the desired selection on the Ordering Guide. If a pilot setpoint is not requested, the regulator will be factory set at the approximate midrange.

### Body Size (Select One)

- NPS 1-1/2 (DN 40)
- NPS 2 (DN 50)

### Body Material and End Connection Style (Select One)

#### Cast Iron

- NPT\*\*\*
- CL125 FF (NPS 2 (DN 50) body only)\*

#### WCC Steel

- NPT\*\*\*
- SWE\*\*
- CL150 RF\*\*
- CL300 RF\*\*
- PN 16/25/40\*

#### CF8M Stainless Steel

- NPT\*\*\*
- CL150 RF\*\*
- CL300 RF\*\*
- PN 16/25/40 RF\*

### Spring Case Material (Select One)

- Cast iron\*\*\*
- WCC Steel\*\*\*
- CF8M Stainless steel\*\*

### Diaphragm Case Material (Select One)

- Cast iron\*\*\*
- WCC Steel\*\*\*
- CF8M Stainless steel\*\*

### Trim Material (Select One)

- 304 Stainless steel\*\*\*
- 316 Stainless steel\*\*

### Diaphragm Material (Select One)

- Nitrile (NBR) (standard)\*\*\*
- Fluorocarbon (FKM)\*\*\*
- Ethylenepropylene (EPDM)\*\*\*
- Silicone (VMQ)\*\*\*

### Disk Material (Select One)

- Nitrile (NBR) (standard)\*\*\*
- Fluorocarbon (FKM)\*\*\*
- Polytetrafluoroethylene (PTFE)\*\*\*
- Ethylenepropylene (EPDM)\*\*\*

Regulators Quick Order Guide	
***	Readily Available for Shipment
**	Allow Additional Time for Shipment
*	Special Order, Constructed from Non-Stocked Parts. Consult your local Sales Office for Availability.
Availability of the product being ordered is determined by the component with the longest shipping time for the requested construction.	

### Orifice Size (Select One)

- 1/4-inch (6,4 mm)\*\*\*
- 3/8-inch (9,5 mm)\*\*\*
- 1/2-inch (13 mm)\*\*\*
- 3/4-inch (19 mm)\*\*\*
- 1-inch (25 mm)\*\*\*
- 1-3/16-inch (30 mm)\*\*\*

### Outlet Pressure Range (Select One)

- 1 to 3-inches w.c. (2 to 7 mbar) Brown\*\*\*
- 3 to 11-inches w.c. (7 to 27 mbar) Iridite\*\*\*
- 6.5-inches w.c. to 1.2 psig (16 mbar to 0,08 bar) Green\*\*\*
- 0.7 to 2 psig (0,05 to 0,14 bar) Blue\*\*\*
- 1 to 3.2 psig (0,07 to 0,22 bar) Orange\*\*\*
- 2 to 5.5 psig (0,14 to 0,38 bar) Metallic with Green stripe\*\*\*
- 4 to 10 psig (0,28 to 0,69 bar) Metallic (Silver)\*\*\*

### Pressure Registration (Select One)

- Internal\*\*\*
- External\*\*

### PTFE Diaphragm Protector (Optional)

- Yes

### CRN (Canadian Registration Number) Required (Optional)

- Yes

### PED (Pressure Equipment Directive) Conformity (Optional)

- Yes

### Replacement Parts Kit (Optional)

- Yes, send one replacement parts kit to match this order.

Tank Blanketing Specification Worksheet	
<b>Application Specifications:</b>	
Tank Size	_____
Pump In Rate	_____
Pump Out Rate	_____
Blanketing Gas (Type and Specific Gravity)	_____
<b>Pressure Requirements:</b>	
Maximum Inlet Pressure ( $P_{1max}$ )	_____
Minimum Inlet Pressure ( $P_{1min}$ )	_____
Control Pressure Setting ( $P_2$ )	_____
Maximum Flow ( $Q_{max}$ )	_____
<b>Accuracy Requirements:</b>	
<input type="checkbox"/> 0.25-inch w.c. (0,6 mbar)	<input type="checkbox"/> 0.5-inch w.c. (1 mbar)
<input type="checkbox"/> 1-inch w.c. (2 mbar)	<input type="checkbox"/> 2-inches w.c. (5 mbar)
<input type="checkbox"/> Other _____	
<b>Other Specifications:</b>	
Is a vapor recovery regulator required? <input type="checkbox"/> Yes <input type="checkbox"/> No	
Special Material Requirements: <input type="checkbox"/> Ductile Iron <input type="checkbox"/> Steel	
<input type="checkbox"/> Stainless Steel <input type="checkbox"/> Other _____	
Other Requirements: _____	

## Industrial Regulators

### Emerson Process Management Regulator Technologies, Inc.

USA - Headquarters  
McKinney, Texas 75069-1872 USA  
Tel: 1-800-558-5853  
Outside U.S. 1-972-548-3574

Europe  
Bologna, Italy 40013  
Tel: +39 051 4190611

Middle East and Africa  
Dubai, United Arab Emirates  
Tel: +971 4811 8100

## Natural Gas Technologies

### Emerson Process Management Regulator Technologies, Inc.

USA - Headquarters  
McKinney, Texas 75069-1872 USA  
Tel: 1-800-558-5853  
Outside U.S. 1-972-548-3574

Asia-Pacific  
Singapore, Singapore 128461  
Tel: +65 6777 8211

Europe  
Bologna, Italy 40013  
Tel: +39 051 4190611  
Gallardon, France 28320  
Tel: +33 (0)2 37 33 47 00

## TESCOM

### Emerson Process Management Tescom Corporation

USA - Headquarters  
Elk River, Minnesota 55330-2445 USA  
Tel: 1-763-241-3238

Europe  
Selmsdorf, Germany 23923  
Tel: +49 (0) 38823 31 0

For further information visit [www.emersonprocess.com/regulators](http://www.emersonprocess.com/regulators)

The Emerson logo is a trademark and service mark of Emerson Electric Co. All other marks are the property of their prospective owners. Fisher is a mark owned by Fisher Controls, Inc., a business of Emerson Process Management.

*The contents of this publication are presented for informational purposes only, and while every effort has been made to ensure their accuracy, they are not to be construed as warranties or guarantees, express or implied, regarding the products or services described herein or their use or applicability. We reserve the right to modify or improve the designs or specifications of such products at any time without notice.*

Emerson Process Management does not assume responsibility for the selection, use or maintenance of any product. Responsibility for proper selection, use and maintenance of any Emerson Process Management product remains solely with the purchaser.