

October 2022

627 Series Pressure Reducing Regulators

Introduction

The 627 Series direct-operated pressure reducing regulators (Figure 1) are for low and high-pressure systems. These regulators can be used with natural gas, air or a variety of other gases. Performance characteristics vary according to construction (see the Specifications section).

Features

- **Internal Relief Valve**—Types 627R, 627LR, 627MR and 627BMR regulators have an internal relief valve, which in many cases eliminates the usual requirement for an external relief valve, thereby reducing equipment and maintenance costs. Refer to the Specifications section for performance data.
- **Types 627R, 627LR, 627MR and 627BMR Travel Stop**—The internal relief valve still works if the disk or linkage fails. The pusher post (Figure 10) contacts the travel stop of the lever retainer and, as the diaphragm continues to rise, it opens the relief valve.
- **Relief Operation Indicator**—A rubber cap (Figure 11) slipped on the vent assembly pops off when the relief valve opens, indicating the relief valve has opened since the last inspection.
- **Easy to Maintain**—Trim parts can be replaced without removing the regulator body from the pipeline. A two-bolt connection between the body and diaphragm casing simplifies disassembly for maintenance.
- **Installation Adaptability**—The diaphragm case and/or regulator body can be rotated in any of four positions to allow regulator installation in locations with limited space (Figure 12). The regulator may be installed in any position without affecting operation as long as the spring case vent is protected from the elements.
- **Application Versatility**—The different 627 Series constructions can be used as farm tap regulators, regulator-relief valves, monitoring regulators, slam-shut regulators or high-pressure industrial regulators.

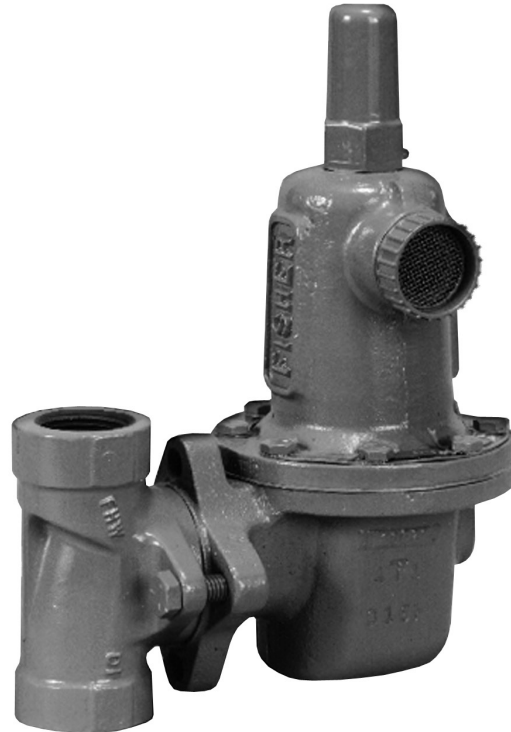

W4793

Figure 1. Typical Type 627 Direct-Operated Pressure Reducing Regulator

- **Extended Body Option**—The Type 627 Long Body is available with same face-to-face dimensions as the Type 630 with threaded NPT end connections.
- **Tamper-Resistant**—An adjusting screw locknut and protective cap (Figure 2) is standard on all 627 Series regulators to discourage tampering with the pressure setting.
- **Wide Range of Flow Capabilities**—A selection of body sizes and orifice sizes is available to satisfy various flow requirements.
- **Balanced Trim Option**—The Type 627BM has a balanced trim design to enhance flow rates and inlet pressure ratings.
- **Tight Shutoff Capability**—A flat-faced disk of Nitrile (NBR), Nylon (PA) or Fluorocarbon (FKM) provides excellent shut-off capability.

627 Series

Specifications

The Specifications section gives some general specifications for the 627 Series regulators. The nameplates give detailed information for a particular regulator as it comes from the factory.

Available Constructions

- Type 627:** Direct-operated pressure reducing regulator equipped with a pitot tube for greater regulated capacities (Figure 2).
- Type 627R:** Type 627 with internal relief and open throat (Figure 3).
- Type 627LR:** Type 627R with light rate relief spring (Figure 3).
- Type 627M:** Type 627 with a stem seal between the body outlet pressure and diaphragm case. Pressure is measured under the diaphragm through the 1/4 NPT downstream control line connection (Figure 2).
- Type 627BM:** Direct-operated pressure reducing regulator with a balanced port and a stem seal between the body outlet pressure and diaphragm case. Pressure is measured under the diaphragm through the 1/4 NPT downstream control line connection.
- Type 627MR:** Type 627M with internal relief (Figure 5).
- Type 627BMR:** Type 627BM with internal relief.
- Type 627H:** Type 627 with a diaphragm limiter to deliver a higher outlet pressure (Figure 6).
- Type 627HM:** Type 627H with a stem seal between the body outlet pressure and diaphragm case. Pressure is measured under the diaphragm through the 1/4 NPT downstream control line connection (Figure 7).
- Type 627BHM:** Type 627BH with a stem seal between the body outlet pressure and diaphragm case. Pressure if measured under the diaphragm through 1/4 NPT downstream control line.
- Type 627OSX:** Type 627 with Type OSE slam-shut device for overpressure protection. Available with Over and Under Pressure Trip points (Figure 9).

Body Sizes and End Connection Styles

BODY SIZE		END CONNECTION STYLE	CONSTRUCTION AVAILABLE
NPS	DN		
3/4	----	NPT	Types 627, 627R, 627LR, 627M, 627MR, 627H and 627HM
1	25	NPT, CL150 RF, CL300 RF, CL600 RF	All
		Long Body	Types 627, 627R, 627LR, 627M, 627MR, 627H and 627HM
1-1/4	32	NPT	Types 627, 627R, 627LR, 627M, 627MR, 627H and 627HM
2	50	NPT, CL150 RF, CL300 RF, CL600 RF	All
		Long Body	Types 627, 627R, 627LR, 627M, 627MR, 627H and 627HM

Maximum Inlet Pressure⁽¹⁾ (Body Rating)

- NPT Stainless steel:** 2000 psig / 138 bar
- Flanged Stainless steel:** 1440 psig / 99.3 bar
- NPT Steel:** 2000 psig / 138 bar
- Flanged Steel:** 1500 psig / 103 bar
- NPT Steel (Type 627OSX):** 1500 psig / 138 bar
- Ductile iron:** 1000 psig / 69.0 bar

Maximum Valve Disk Inlet Pressure Rating⁽¹⁾

- Nylon (PA) Disk:** 2000 psig / 138 bar
- Nitrile (NBR) Disk:** 1000 psig / 69.0 bar
- Fluorocarbon (FKM) Disk:** 300 psig / 20.7 bar

Maximum Operating Inlet and Outlet Pressure Ranges⁽¹⁾

See Table 3 for pressures by orifice size and spring range

Maximum Spring and Diaphragm Casing Pressure⁽¹⁾

See Table 2

Maximum Body Outlet Pressure⁽¹⁾⁽²⁾

- Types 627M, 627BM, 627MR, 627BMR, 627HM and 627BHM only**
- NPT Steel:* 2000 psig / 138 bar
- Flanged Steel:* 1500 psig / 103 bar
- Ductile iron:* 1000 psig / 69.0 bar
- Type 627OSX**
- NPT Steel:* 1500 psig / 103 bar

Orifice Sizes

See Table 3

Internal Relief Performance

- Type 627R:** See Table 4 and Figure 13
- Type 627LR:** See Table 5
- Types 627MR and 627BMR:** Limited by field-installed control line piping

Regulator Capacities

- Type 627, 627M, 627BM, 627MR or 627BMR:** See Tables 6 to 10
- Type 627H, 627HM or 627BHM:** See Tables 11 to 13
- Type 627R:** See Tables 14 to 15

Flow Coefficients

See Table 16

IEC Sizing Coefficients

See Table 17

Construction Materials

- Body:** Ductile iron, WCC steel, Stainless steel
- Spring Case and Diaphragm Case:** WCC steel, Stainless steel, ductile iron or die cast aluminum

1. The pressure/temperature limits in this Bulletin or any applicable standard limitation should not be exceeded.

2. Types 627, 627H, 627R and 627LR are limited by maximum diaphragm casing pressure.

- continued -

Specifications (continued)

Construction Materials (continued)

Orifice: Aluminum (standard) or Stainless steel

Disk Holder with Valve Disk:

2000 psig / 138 bar Maximum Pressure:

Aluminum or Stainless steel with Nylon (PA)

1000 psig / 69.0 bar Maximum Pressure:

Aluminum (standard) or Stainless steel with Nitrile (NBR)

300 psig / 20.7 bar Maximum Pressure: Stainless steel or Aluminum with Fluorocarbon (FKM) disk

O-rings: Nitrile (NBR) or Fluorocarbon (FKM)

Diaphragm:

Types 627H and 627HM: Neoprene (CR)

All Others: Nitrile (NBR) or Fluorocarbon (FKM)

Relief Indicator

For Types 627R, 627LR, 627MR and 627BMR (see Figure 11)

Elastomer Temperature Capabilities⁽¹⁾⁽²⁾

MATERIAL	DISK/ DIAPHRAGM	TEMPERATURE	
		°F	°C
Nitrile (NBR)	Disk	-40 to 180	-40 to 82
	Diaphragm		
Fluorocarbon (FKM)	Disk	0 to 180	-18 to 82
	Diaphragm		
Nylon (PA)	Disk	-40 to 180	-40 to 82
Neoprene (CR) for Types 627H, 627HM and 627BHM only	Diaphragm	-40 to 180	-40 to 82
Neoprene (CR) for Types 627HOSX, 627HMOSX and 627BHMOSX only	Diaphragm	-20 to 180	-29 to 82
Nitrile (NBR) for Types 627OSX, 627MOSX and 627BMOX only	Diaphragm	-20 to 180	-29 to 82

1. The pressure/temperature limits in this Bulletin or any applicable standard limitation should not be exceeded.

2. Stainless steel body is rated to -40°F / -40°C. Steel and Ductile iron bodies are rated to -20°F / -29°C.

Pressure Registration

Type 627, 627H, 627R or 627LR: Internal

Type 627M, 627BM, 627HM, 627BHM, 627MR

or 627BMR: External through 1/4 NPT internal control line connection in the diaphragm casing

De-Icer System

See Figure 14 and Type 627M De-Icer System Application section

Spring Case Orientation and Vent Location

See Figure 12

Spring Case Vent Connection

3/4 NPT with removable screened vent assembly

Approximate Weight

627 Series

Ductile iron, Steel or Stainless steel Casings:

10 lbs / 5 kg

Aluminum Casing: 6.3 lbs / 3 kg

Type 627OSX

NPS 1 / DN 25: 40 lbs / 18 kg

NPS 2 / DN 50: 42 lbs / 19 kg

Product Description

Types 627 and 627H Direct-Operated Pressure Reducing Regulators—The Types 627 and 627H regulators provide economical pressure reducing control for a variety of residential, commercial and industrial applications. The regulator pitot tube located in a high velocity stream provides dynamic boost that compensates for outlet pressure drop (see Tables 6 through 15).

Types 627BM, 627BMR or 627BHM Balanced Port Design—The Type 627BM combines the high-flowing capacity of a small pilot-operated regulator with the speed of a self-operated regulator with the addition of a balanced trim design. The balanced trim neutralizes inlet sensitivity to optimize inlet pressure ratings and maximize flow rates. With this design, a large 9/16 in. / 14.3 mm orifice is used for all Type 627BM applications without reduced inlet pressure ratings. External sensing only.

Type 627 Long Body—The Type 627 Long Body regulator can be used as a drop-in replacement for existing Type 630 installations without the need to modify piping.

Internal Relief for Type 627R, 627LR, 627MR or 627BMR Regulator—The Types 627R and 627LR internal relief performance values (Tables 4 and 5) were obtained **by removing the disk assembly** from the regulator, see Figure 13. For the Type 627R, 627LR or 627MR regulator, the internal relief across the diaphragm (Figure 3 or 4) provides overpressure protection in many applications. As outlet pressures build-up above the start-to-discharge point, the diaphragm moves off the relief valve seat allowing the excess pressure to bleed out through the screened vent.

627 Series

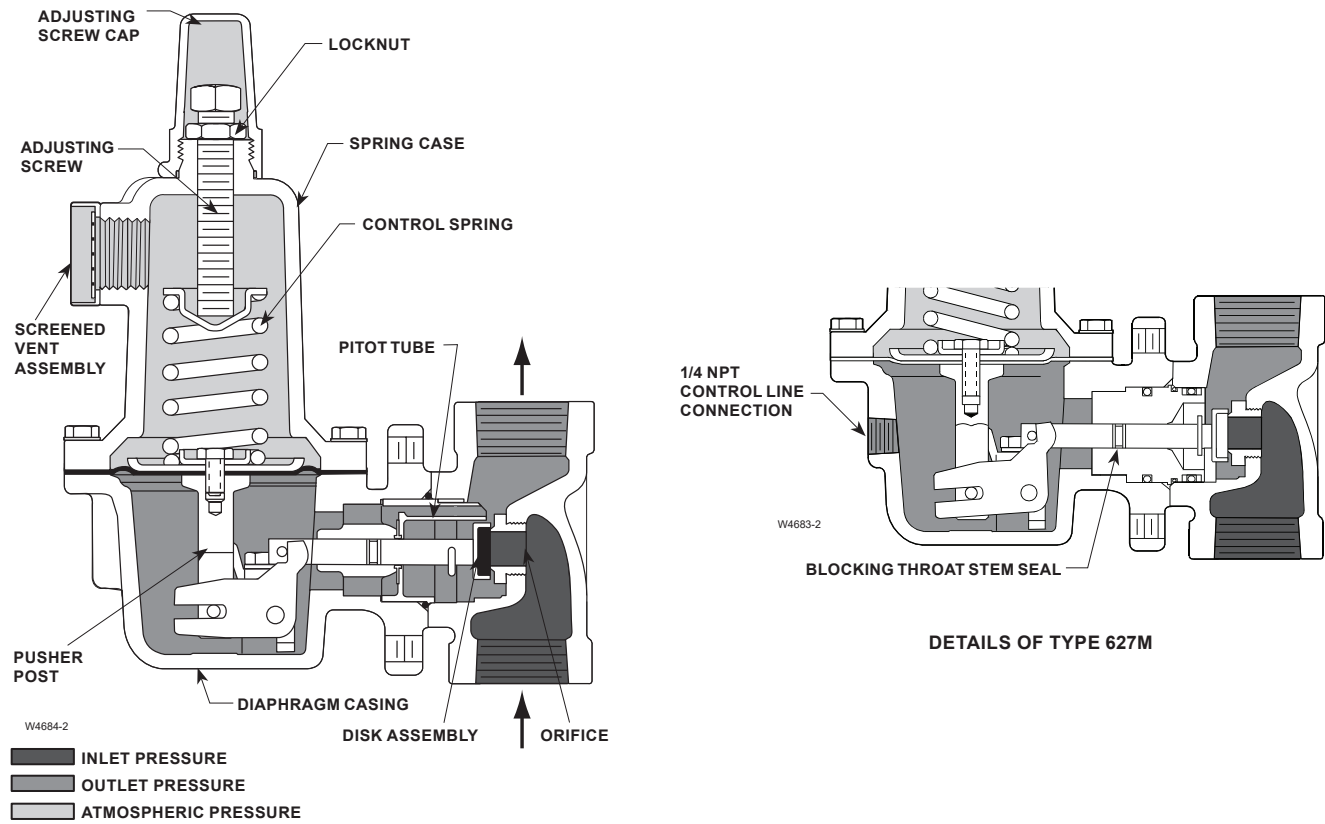

Figure 2. Types 627 and 627M Operational Schematics

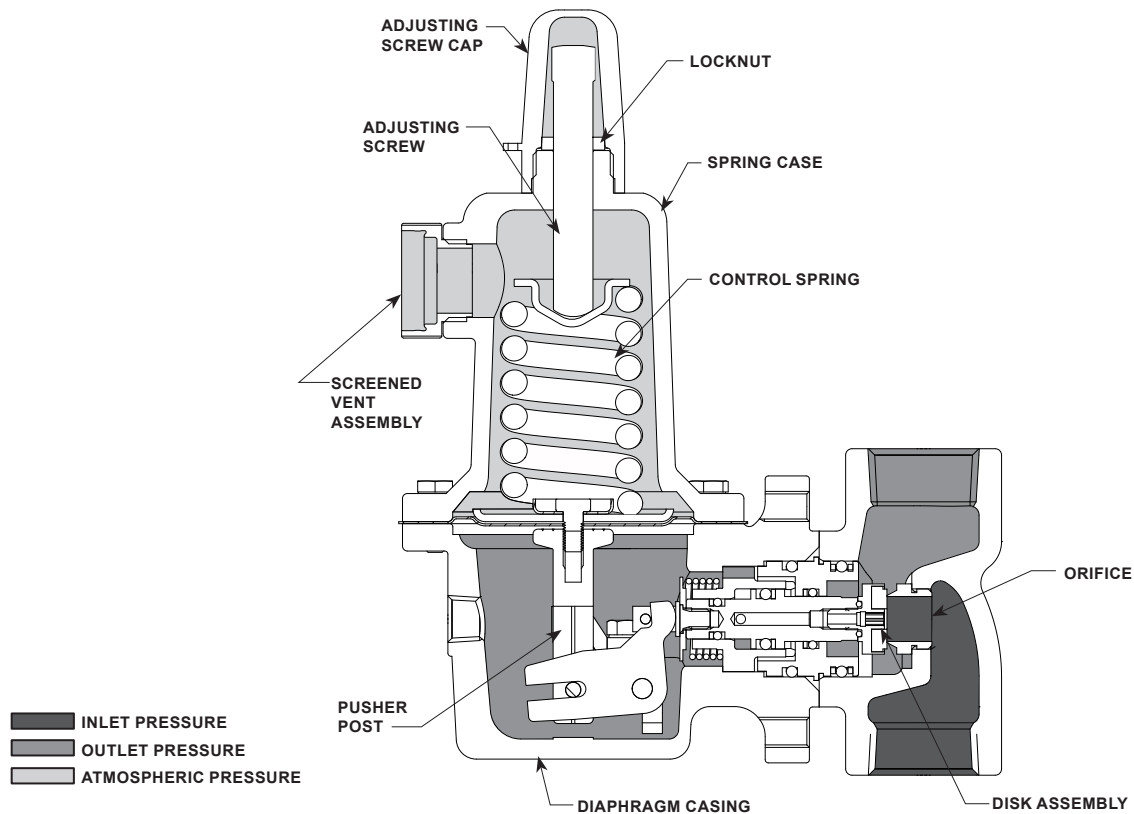

Figure 3. Type 627BM Operational Schematics

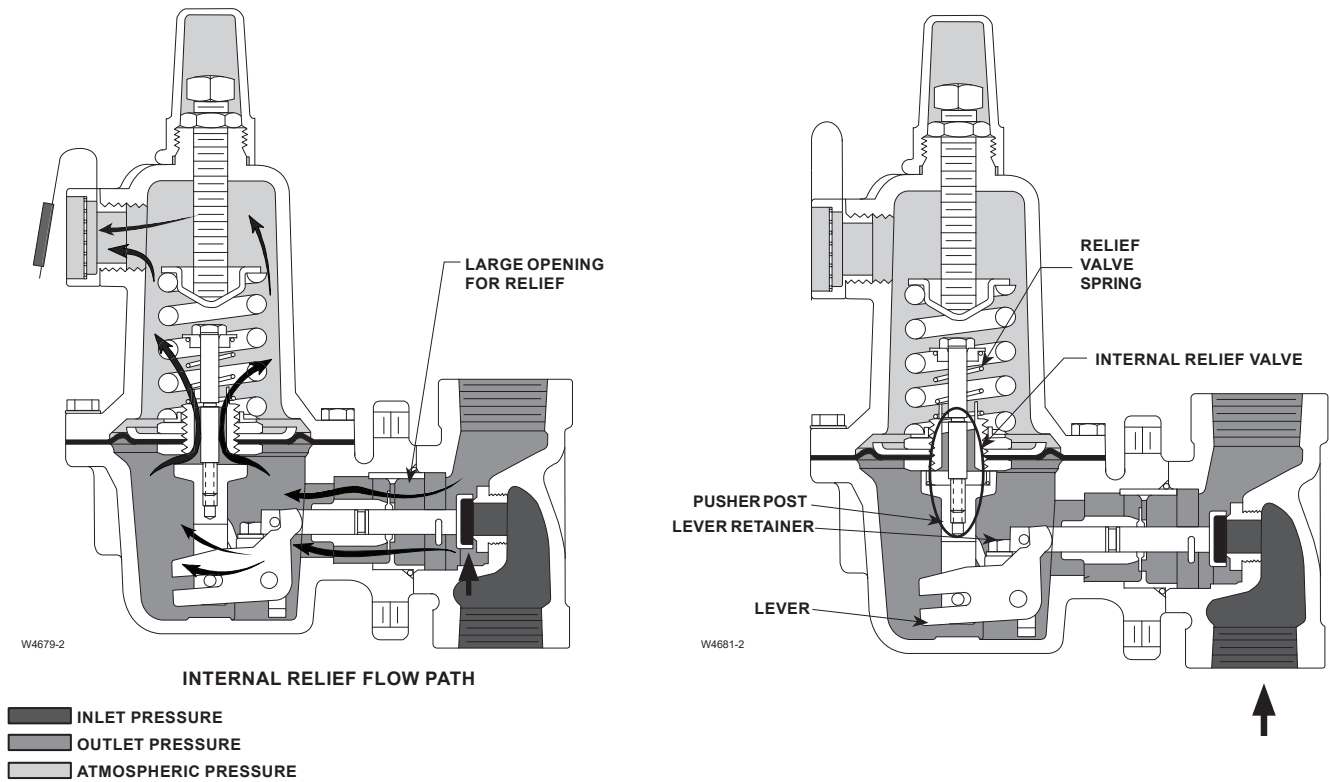

Figure 4. Types 627R and 627LR Operational Schematics

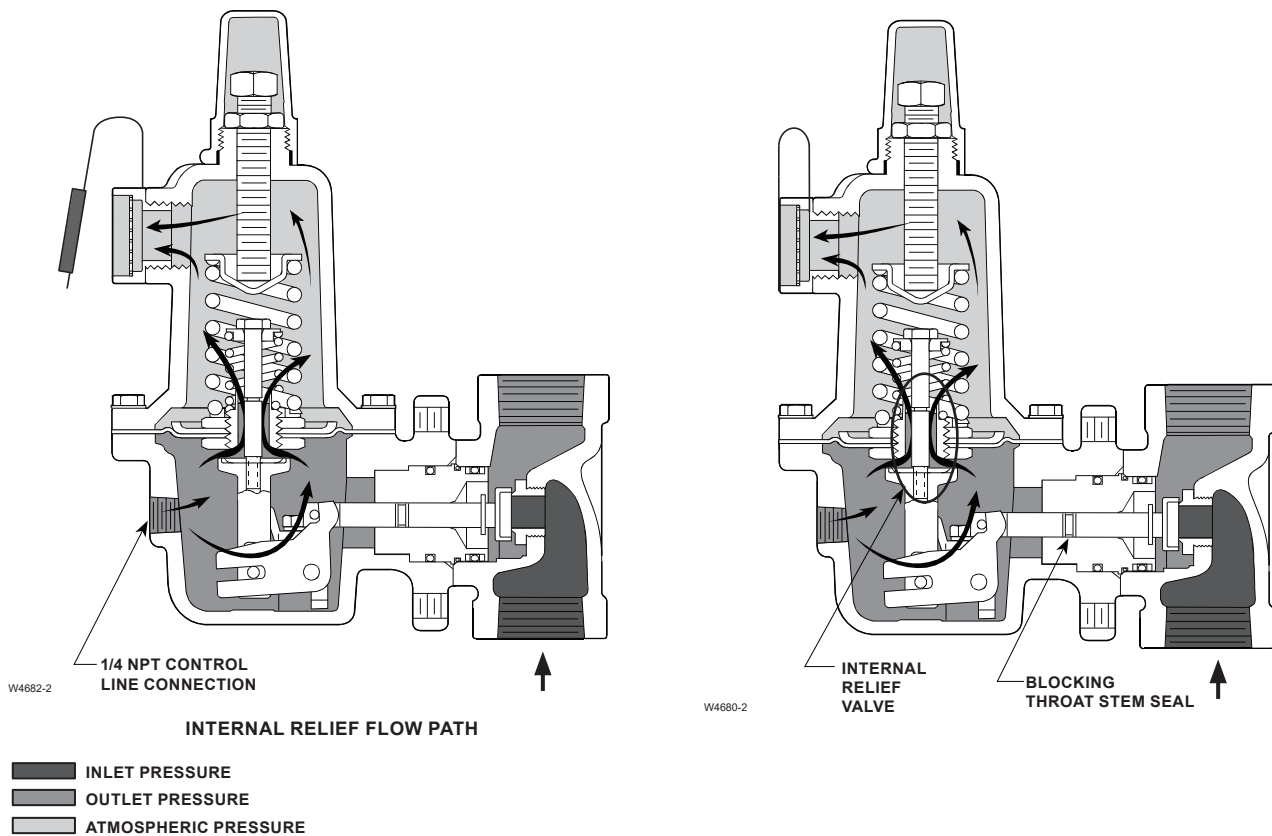

Figure 5. Type 627MR Operational Schematics

627 Series

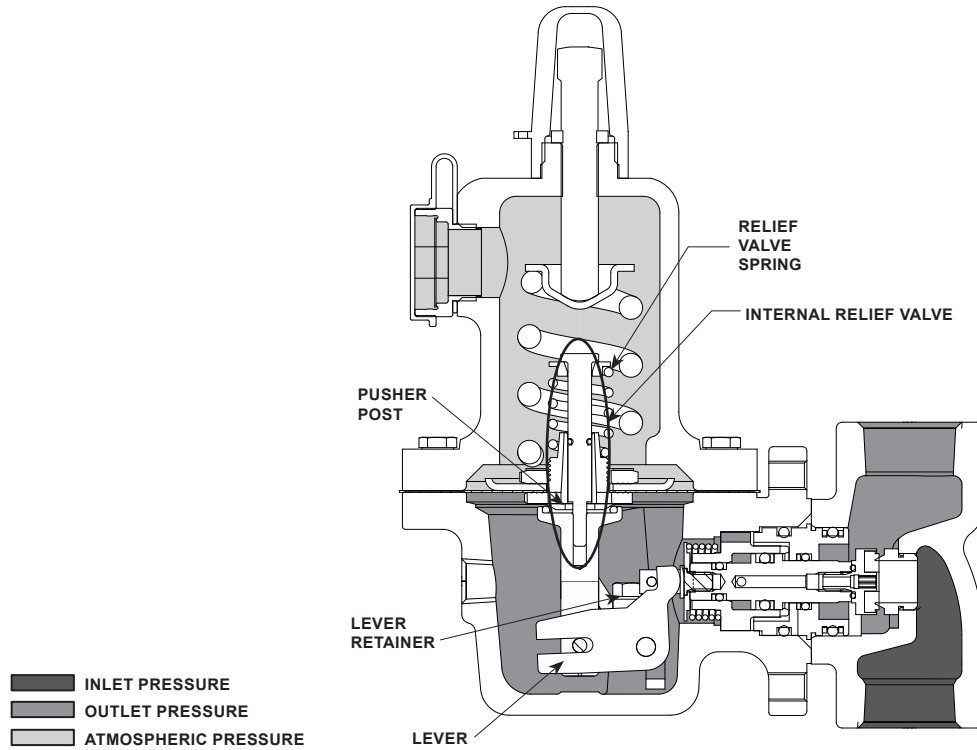

Figure 6. Type 627BMR Operational Schematics

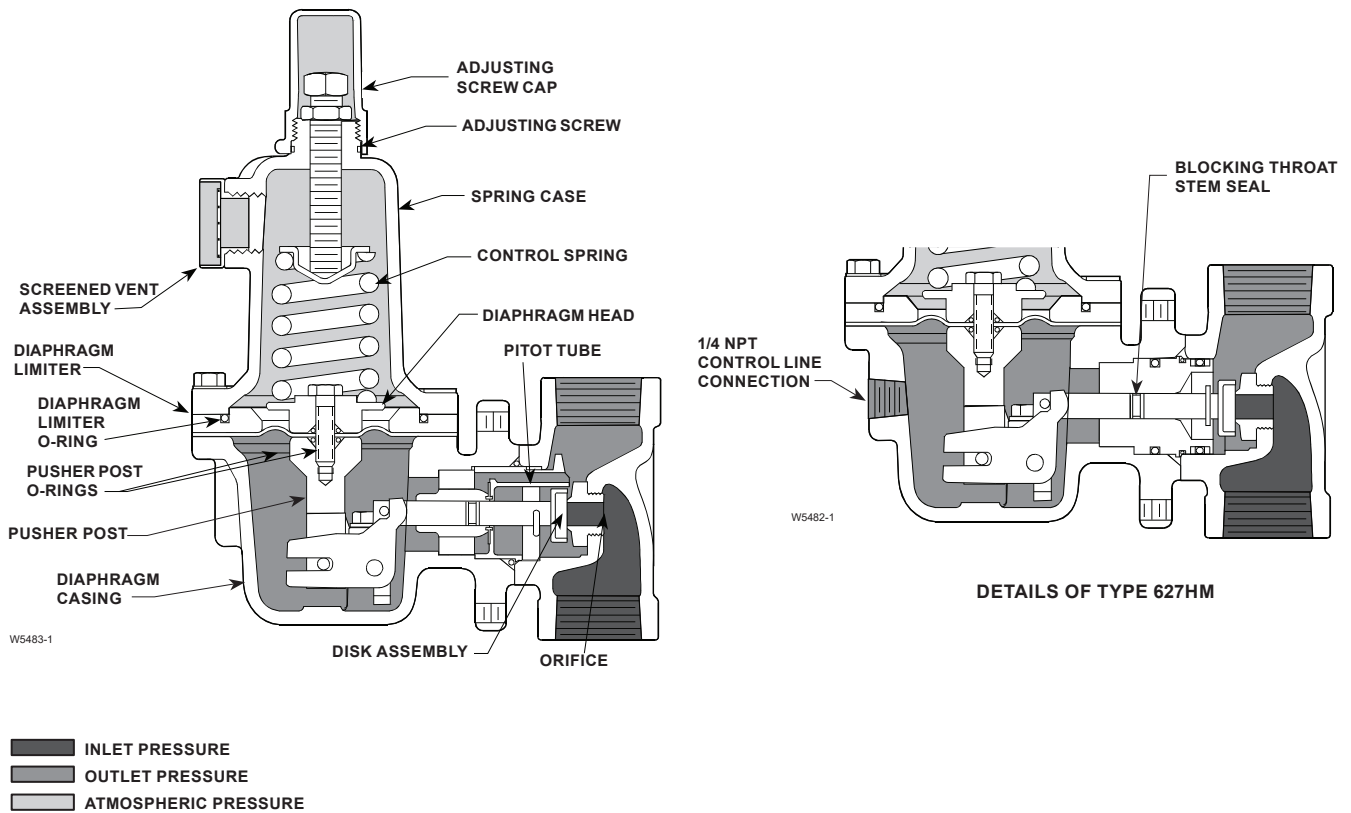

Figure 7. Types 627H and 627HM Operational Schematics

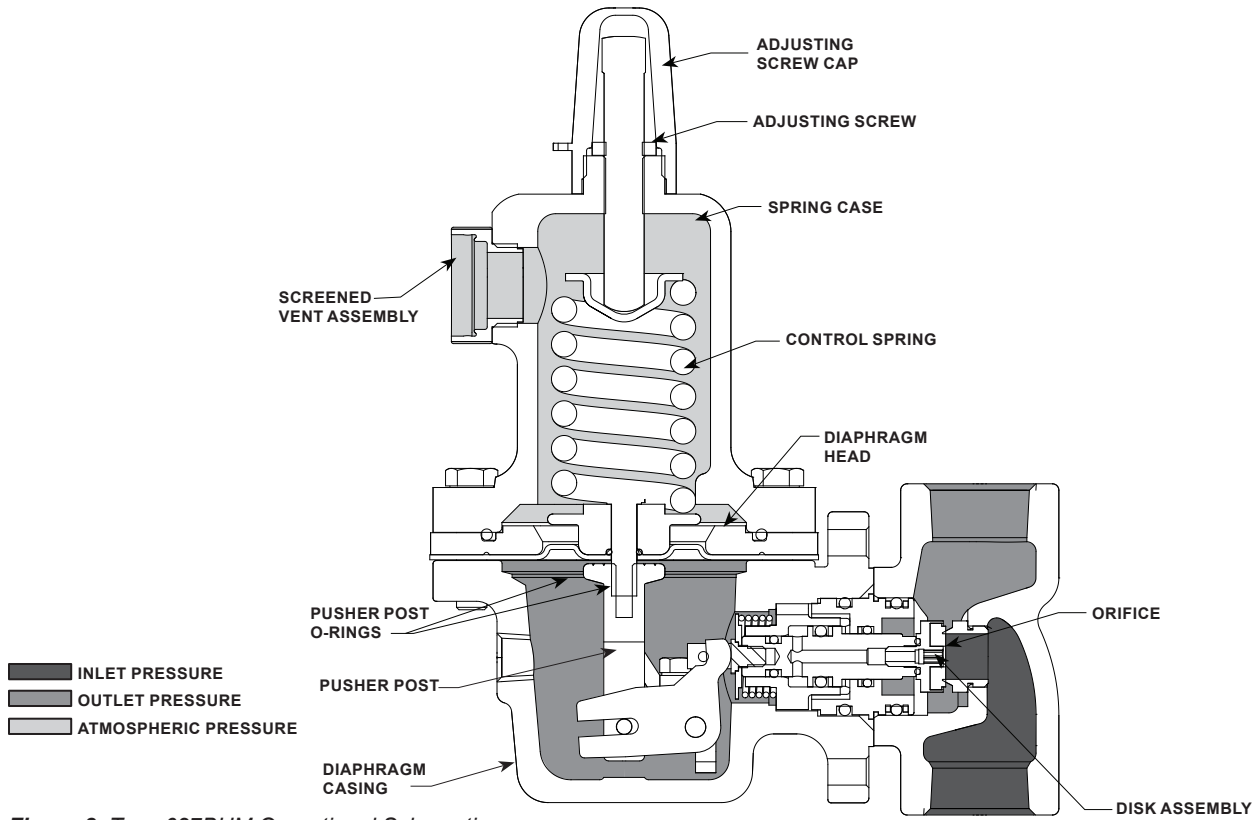
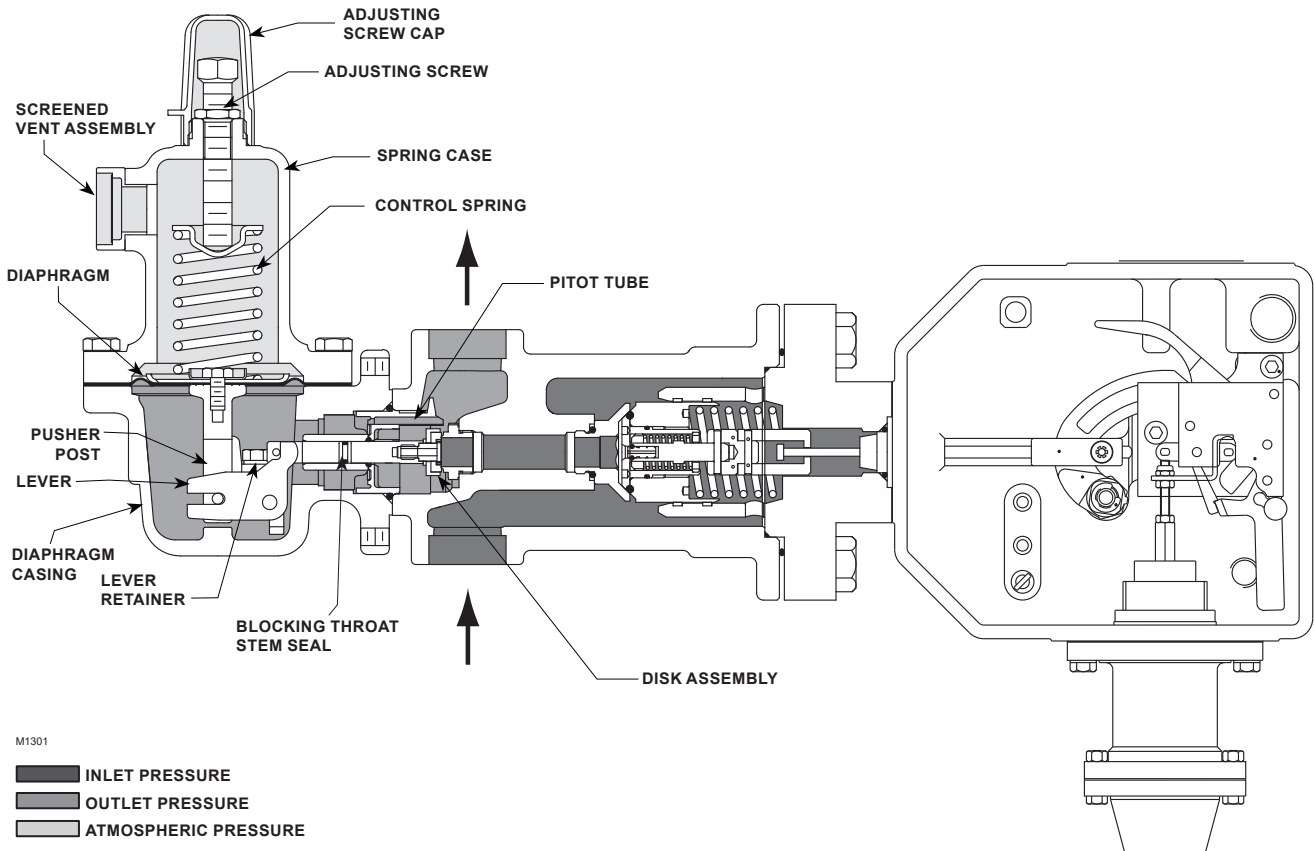

Figure 8. Type 627BHM Operational Schematics



M1301

Figure 9. Type 627OSX with Type 627 Regulator and Type OSE Slam-Shut Valve

627 Series

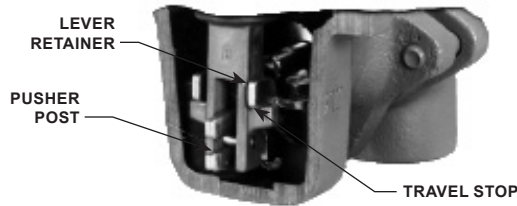

W4666-1

Figure 10. Internal Relief Construction Feature

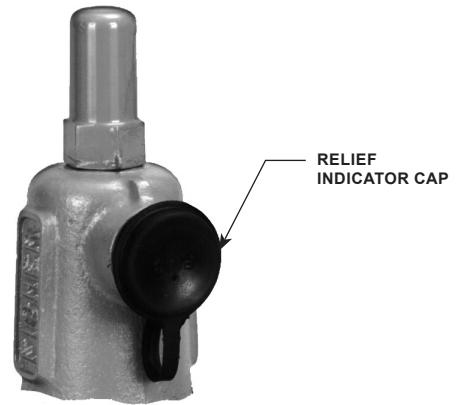

W4665-1

Figure 11. Relief Indicator

Table 1. Maximum Cold Working Pressure of Body Inlet (Body Rating)⁽¹⁾⁽²⁾

BODY SIZE		BODY MATERIAL	END CONNECTION	MAXIMUM INLET PRESSURE	
NPS	DN			psig	bar
3/4	20	Ductile iron	NPT	1000	69.0
		Steel	NPT	2000	138
		Stainless steel	NPT	2000	138
1 2	25 50	Ductile iron	NPT	1000	69.0
			NPT	2000	138
		Steel	CL150 RF	290	20.0
			CL300 RF	750	51.7
			CL600 RF	1500	103
1 2	25 50	Stainless steel	PN 16/25/40	580	40.0
			CL150 RF	275	19.0
			CL300 RF	720	49.6
			CL600 RF	1440	99.3
1-1/4	32	Ductile iron	NPT	1000	69.0

1. The pressure/temperature limits in this Bulletin and any applicable standard or code should not be exceeded.
 2. Temperature may decrease these maximum pressures.

For extra protection, should failure conditions exist which would prevent normal operation of the regulator (for example, disk broken off or disk erosion), the pusher post contacts the lever retainer (Figure 10) causing the relief valve assembly to open. Since the diaphragm continues to rise as downstream pressure builds, it opens the relief valve, thereby opening the valve. This internal relief may be adequate for the application.

Downstream Control Line for Type 627M, 627BM 627HM, 627BHM, 627MR or 627BMR Regulator—A Type 627M, 627BM, 627HM, 627BHM, 627MR or 627BMR regulator has a blocking throat stem seal with O-rings and a 1/4 NPT control line connection in the diaphragm case (Figure 4). A regulator with a downstream control line is used for monitoring applications or other applications where other equipment is installed between the regulator and the pressure control point. The stem seal separates the body outlet pressure from the diaphragm case.

Principle of Operation

627 Series Regulator

Refer to Figures 2 through 8. When downstream demand decreases, the pressure under the diaphragm increases. This pressure overcomes the regulator setting (which is set by a spring). Through the action of the pusher post assembly, lever and valve stem the valve disk moves closer to the orifice and reduces gas flow. If demand downstream increases, pressure under the diaphragm decreases. Spring force pushes the pusher post assembly downward and the valve disk moves away from the orifice allowing more flow through the body to the downstream system.

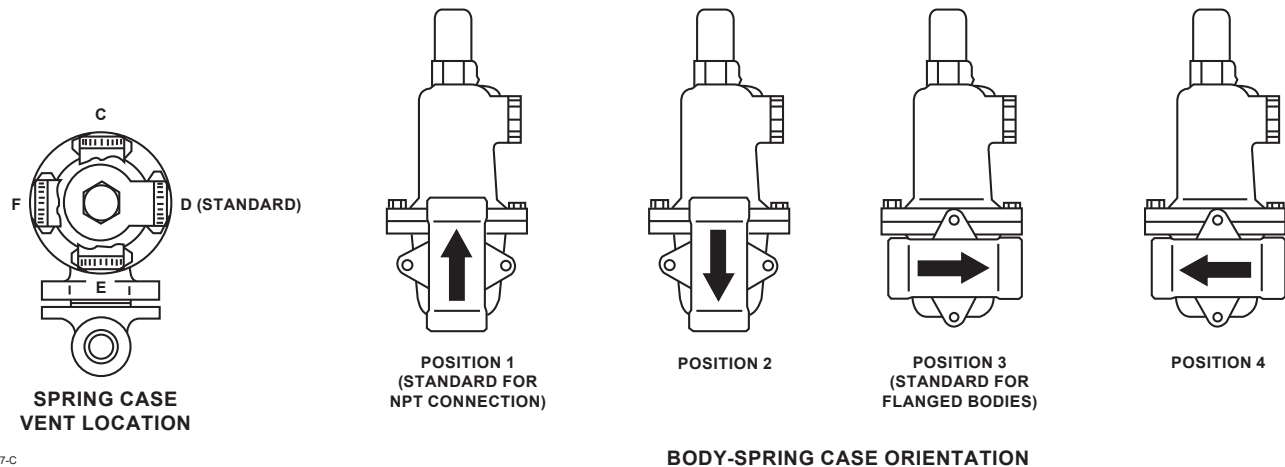

10B7447-C
A3726

Figure 12. 627 Series Spring Case and Vent Location

Type 627OSX Slam-Shut Device

The slam-shut device on the Type 627 can provide either overpressure (OPSO) or overpressure (OPSO) and underpressure (UPS0) protection by completely shutting off the flow of gas to the downstream system. Available on Types 627, 627H, 627M, 627HM, 627BM and 627BHM.

Pressure is registered on one side of the diaphragm, piston or bellows and is opposed by the setpoint control spring of the manometric sensing device. The Type OSX slam-shut valve tripping pressure is determined by the setting of the control spring.

Overpressure – when the downstream pressure increases above the setpoint, the pressure on top of the diaphragm overcomes the spring setting and moves the manometric device stem.

Underpressure – when the downstream pressure decreases below the setpoint, the control spring pressure below the diaphragm overcomes the downstream pressure and pushes the diaphragm which moves the manometric device stem.

Installation

Regulator operation within ratings does not preclude the possibility of damage from debris in the lines or from external sources. A regulator should be inspected for damage periodically and after any overpressure condition. Ensure that the operating temperature capabilities listed in Specifications section are not exceeded.

Note

If the regulator is shipped mounted on another unit, install that unit according to the appropriate Instruction Manual.

Overpressure Protection

627 Series regulators have outlet pressure ratings that are lower than their inlet pressure ratings. A pressure-relieving or pressure-limiting device must be provided by the user for the Types 627, 627H, 627M, 627BM, 627HM and 627BHM regulators if the inlet pressure can exceed the outlet pressure rating, since these regulators do not have internal relief.

Types 627R and 627LR regulators provide internal relief which limits the total outlet pressure build-up over setpoint. Use Table 4 or 5 and the following example to determine the maximum inlet pressure allowed to keep the maximum allowable downstream pressure from being exceeded.

If the maximum allowable downstream system pressure is less than any of the pressures shown in the third column of Tables 4 and 5, use a separate relief valve or a monitor regulator since the internal relief will not open at pressures lower than shown in the table.

If the actual inlet pressure is higher than the pressure shown, in the Maximum Inlet Pressure column, to protect to the level shown, an additional relief valve is needed to supplement the relief capacity of the Type 627R or 627LR internal relief or a full capacity separate relief valve or monitor regulator may be used.

627 Series

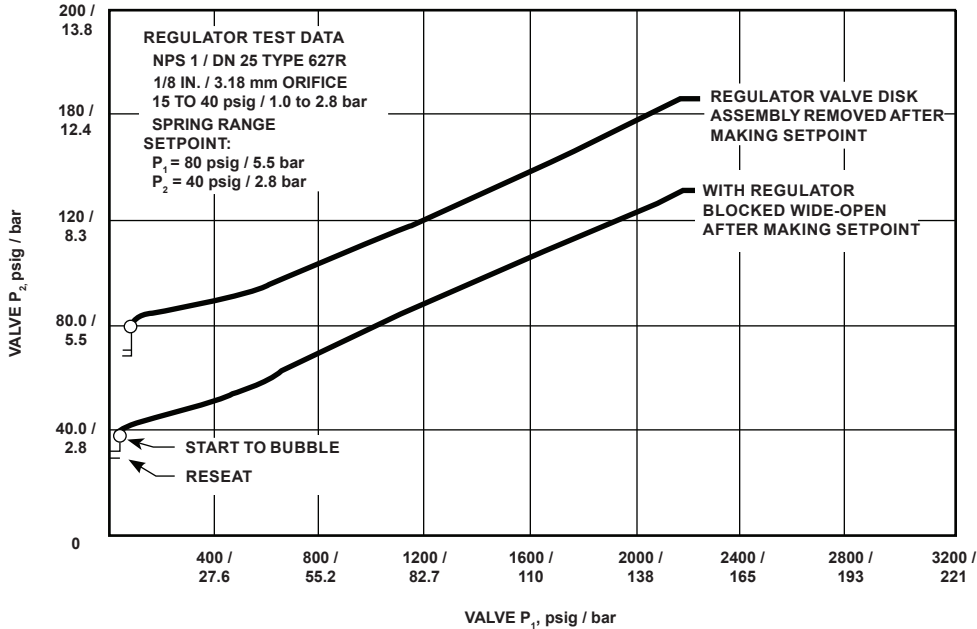

Figure 13. Relief Testing Methods, Outlet vs. Inlet Pressures

Table 2. Maximum Spring and Diaphragm Casing Pressure⁽¹⁾

MAXIMUM PRESSURE DESCRIPTION	DIAPHRAGM CASING MATERIAL	TYPE 627		TYPES 627R AND 627LR		TYPES 627M AND 627BM		TYPES 627MR AND 627BMR		TYPES 627H, 627HM AND 627BHM	
		psig	bar	psig	bar	psig	bar	psig	bar	psig	bar
Maximum pressure to spring and diaphragm casings to prevent leak to atmosphere other than relief action (internal parts damage may occur)	Die cast aluminum	250	17.2	250	17.2	Not Available		Not Available		Not Available	
	Ductile iron					250	17.2	Not Available		Not Available	
	Steel or Stainless steel					250	17.2	250	17.2	800	55.2
Maximum pressure to spring and diaphragm casings to prevent burst of casings during abnormal operation (leak to atmosphere and internal parts damage may occur)	Die cast aluminum	375	25.9	375	25.9	Not Available		Not Available		Not Available	
	Ductile iron	465	32.1	465	32.1	465	32.1	465	32.1	Not Available	
	Steel or Stainless steel	1500	103	1500	103	1500	103	1500	103	1500	103
Maximum diaphragm casing overpressure (above setpoint) to prevent damage to internal parts	All materials	60	4.1	120	8.3	60	4.1	120	8.3	120	8.3

1. If the spring case is pressurized, a metal adjusting screw cap is required. Contact your local Sales Office for details.

To size a supplemental relief valve to use with the Type 627R or 627LR:

1. Use the universal sizing equation to calculate the wide-open capacity of the regulator port (Q_1) using:
 - a. Actual inlet pressure (P_1), psia
 - b. Maximum allowable downstream system pressure (P_2) from Table 4 or 5, column 3
 - c. C_g from Table 16

Given:

Desired outlet pressure setting : 40 psig / 2.8 bar
 Maximum allowable downstream pressure : 125 psig / 8.6 bar
 Orifice size : 1/4 in. / 6.35 mm

What is the maximum inlet pressure?

Control spring range (first column) : 35 to 80 psig / 2.4 to 5.5 bar
 Outlet pressure setting (second column) : 40 psig / 2.8 bar
 Maximum allowable downstream pressure (third column) : 125 psig / 8.6 bar
 Orifice size column across from the 125 psig / 8.6 bar maximum allowable pressure and the column under 1/4 in. / 6.4 mm orifice size : 1/4 in. / 6.4 mm

Table 3. Maximum Inlet Pressure and Outlet Pressure Ranges

TYPE	OUTLET PRESSURE RANGE, SPRING PART NUMBER AND COLOR CODE	ORIFICE SIZE		MAXIMUM INLET PRESSURE ⁽¹⁾					
				Nylon (PA) Disk		Nitrile (NBR) Disk		Fluorocarbon (FKM) Disk	
		In.	mm	psig	bar	psig	bar	psig	bar
627 and 627M ⁽³⁾	5 to 20 psig ⁽²⁾ / 0.34 to 1.4 bar ⁽²⁾ 10B3076X012 Yellow	3/32	2.4	2000	138	1000	69.0	300	20.7
		1/8	3.2	1000	69.0	1000	69.0	300	20.7
		3/16	4.8	750	51.7	750	51.7	300	20.7
		1/4	6.4	500	34.5	500	34.5	300	20.7
		3/8	9.5	300	20.7	300	20.7	300	20.7
		1/2	13	250	17.2	250	17.2	250	17.2
	15 to 40 psig / 1.0 to 2.8 bar 10B3077X012 Green	3/32	2.4	2000	138	1000	69.0	300	20.7
		1/8	3.2	1500	103	1000	69.0	300	20.7
		3/16	4.8	1000	69.0	1000	69.0	300	20.7
		1/4	6.4	750	51.7	750	51.7	300	20.7
		3/8	9.5	500	34.5	500	34.5	300	20.7
		1/2	13	300	20.7	300	20.7	300	20.7
	35 to 80 psig / 2.4 to 5.5 bar 10B3078X012 Blue	3/32	2.4	2000	138	1000	69.0	300	20.7
		1/8	3.2	2000	138	1000	69.0	300	20.7
		3/16	4.8	1750	121	1000	69.0	300	20.7
		1/4	6.4	1500	103	1000	69.0	300	20.7
3/8		9.5	1000	69.0	1000	69.0	300	20.7	
1/2		13	750	51.7	750	51.7	300	20.7	
70 to 150 psig / 4.8 to 10.3 bar 10B3079X012 Red	3/32	2.4	2000	138	1000	69.0	300	20.7	
	1/8	3.2	2000	138	1000	69.0	300	20.7	
	3/16	4.8	2000	138	1000	69.0	300	20.7	
	1/4	6.4	1750	121	1000	69.0	300	20.7	
	3/8	9.5	1250	86.2	1000	69.0	300	20.7	
	1/2	13	750	51.7	750	51.7	300	20.7	
627R and 627MR	5 ⁽²⁾ to 20 psig / 0.34 ⁽²⁾ to 1.4 bar 10B3076X012 Yellow	3/32	2.4	2000	138	1000	69.0	300	20.7
		1/8	3.2	1000	69.0	1000	69.0	300	20.7
		3/16	4.8	750	51.7	750	51.7	300	20.7
		1/4	6.4	500	34.5	500	34.5	300	20.7
		3/8	9.5	300	20.7	300	20.7	300	20.7
		1/2	13	200	13.8	200	13.8	200	13.8
	15 to 40 psig / 1.0 to 2.8 bar 10B3077X012 Green	3/32	2.4	2000	138	1000	69.0	300	20.7
		1/8	3.2	1500	103	1000	69.0	300	20.7
		3/16	4.8	1000	69.0	1000	69.0	300	20.7
		1/4	6.4	750	51.7	750	51.7	300	20.7
		3/8	9.5	300	20.7	300	20.7	300	20.7
		1/2	13	200	13.8	200	13.8	200	13.8
	35 to 80 psig / 2.4 to 5.5 bar 10B3078X012 Blue	3/32	2.4	2000	138	1000	69.0	300	20.7
		1/8	3.2	1750	121	1000	69.0	300	20.7
		3/16	4.8	1000	69.0	1000	69.0	300	20.7
		1/4	6.4	750	51.7	750	51.7	300	20.7
3/8		9.5	300	20.7	300	20.7	300	20.7	
1/2		13	200	13.8	200	13.8	200	13.8	
70 to 150 psig / 4.8 to 10.3 bar 10B3079X012 Red	3/32	2.4	2000	138	1000	69.0	300	20.7	
	1/8	3.2	1000	69.0	1000	69.0	300	20.7	
	3/16	4.8	500	34.5	500	34.5	300	20.7	
	1/4	6.4	300	20.7	300	20.7	300	20.7	
	3/8	9.5	200	13.8	200	13.8	200	13.8	
	1/2	13	200	13.8	200	13.8	200	13.8	
627LR	15 to 40 psig / 1.0 to 2.8 bar 10B3077X012 Green	3/32	2.4			1000	69.0	300	20.7
		1/8	3.2			1000	69.0	300	20.7
		3/16	4.8			750	51.7	300	20.7
		1/4	6.4			500	34.5	300	20.7
627H and 627HM ⁽³⁾	140 to 250 psig / 9.7 to 17.2 bar 10B3078X012 Blue	3/32	2.4	2000	138	1000	69.0		
		1/8	3.2	2000	138	1000	69.0		
		3/16	4.8	1750	121	1000	69.0		
		1/4	6.4	1500	103	1000	69.0		
		3/8	9.5	1000	69.0	750	51.7		
		1/2	13	750	51.7	500	34.5		
	240 to 500 psig / 16.5 to 34.5 bar 10B3079X012 Red	3/32	2.4	2000	138	1000	69.0		
		1/8	3.2	2000	138	1000	69.0		
		3/16	4.8	1750	121	1000	69.0		
		1/4	6.4	1500	103	1000	69.0		

— Shaded areas indicate that Fluorocarbon (FKM) and Nylon (PA) disk material are not available.

1. For inlet pressure in excess of 1000 psig / 69.0 bar, refer to the maximum body and disk pressure ratings in the Specifications section.

2. For pressure settings under 10 psig / 0.69 bar, inlet pressure should be limited to approximately 100 psig / 6.9 bar so the setpoint adjustment can be obtained.

3. The unbalance forces change from the wide-open monitor mode to an active regulator mode such that the Type 627M or 627HM should have a 3/8 in. / 9.5 mm or larger orifice.

- continued -

627 Series

Table 3. Maximum Inlet Pressure and Outlet Pressure Ranges (continued)

TYPE	OUTLET PRESSURE RANGE, SPRING PART NUMBER AND COLOR CODE	ORIFICE SIZE		MAXIMUM INLET PRESSURE ⁽¹⁾					
				Nylon (PA) Disk		Nitrile (NBR) Disk		Fluorocarbon (FKM) Disk	
		in.	mm	psig	bar	psig	bar	psig	bar
627BM and 627BMR	5 ⁽²⁾ to 30 psig / 0.34 ⁽²⁾ to 1.4 bar 10B3076X012 Yellow	9/16	14.3	1500	103	1000	69		
	15 to 40 psig / 1.0 to 2.8 bar 10B3077X012 Green								
	35 to 80 psig / 2.4 to 5.5 bar 10B3078X012 Blue								
627BHM	70 to 150 psig / 4.8 to 10.3 bar 10B3079X012 Red								
	140 to 250 psig / 9.7 to 17.2 bar 10B3078X012 Blue								
	240 to 500 psig / 16.5 to 34.5 bar 10B3079X012 Red								

— Shaded areas indicate that Fluorocarbon (FKM) are not available.

1. For inlet pressure in excess of 1000 psig / 69.0 bar, refer to the maximum body and disk pressure ratings in the Specifications section.

2. For pressure settings under 10 psig / 0.69 bar, inlet pressure should be limited to approximately 100 psig / 6.9 bar so the setpoint adjustment can be obtained.

From Table 4, the maximum inlet pressure for this example is 300 psig / 20.7 bar.

In many cases the internal relief of Types 627R and 627LR offers full capacity overpressure protection. No additional relief capacity is needed if the actual inlet pressure is equal to or less than the inlet pressure shown under the Maximum Inlet Pressure column heading in Tables 4 and 5.

2. Use the universal sizing equation to calculate the internal relief flow (Q_2) using:

- Maximum inlet pressure (P_1) from Table 4 columns 4 through 9 for Type 627R or Table 5 columns 4 through 7 for Type 627LR (use the pressure from the table even though the actual pressure will be higher). Remember the equation requires pressures to be converted to psia.
- Maximum allowable downstream system pressure (P_2) from Table 4 or 5
- C_g from Table 16

3. Calculate supplemental relief capacity:

- Q supplemental relief = $Q_1 - Q_2$

Example:

Outlet pressure setting : 10 psig / 0.69 bar
 Maximum allowable downstream system pressure : 60 psig / 4.1 bar
 Inlet pressure : 300 psig / 20.7 bar
 Orifice size : 1/4 in. / 6.4 mm

Step 1.

$$P_1 = 300 \text{ psig} / 20.7 \text{ bar}$$

$$P_2 = 60 \text{ psig} / 4.1 \text{ bar}$$

$$C_g, 1/4 \text{ in.} / 6.4 \text{ mm orifice} = 50$$

$$Q_1 = 20,300 \text{ SCFH} / 544 \text{ Nm}^3/\text{h}$$

Step 2.

$$P_1 = 190 \text{ psig} / 13.1 \text{ bar}$$

$$P_2 = 60 \text{ psig} / 4.1 \text{ bar}$$

$$C_g, 1/4 \text{ in.} / 6.4 \text{ mm orifice} = 50$$

$$Q_2 = 13,200 \text{ SCFH} / 354 \text{ Nm}^3/\text{h}$$

Step 3.

$$Q \text{ supplemental relief} = Q_1 - Q_2$$

$$Q \text{ supplemental relief} = 20,300 - 13,200 = 7100 \text{ SCFH} / 544 - 354 = 190 \text{ Nm}^3/\text{h}$$

Overpressurizing any portion of a regulator or associated equipment may cause personal injury, leakage or property damage due to bursting of pressure-containing parts or explosion of accumulated gas.

If needed, provide appropriate pressure-relieving or pressure-limiting devices to ensure that none of the specifications are exceeded. Regulator operation within ratings does not prevent the possibility of damage from external sources such as debris in the pipeline.

Refer to the relief sizing coefficients in Table 16 and the Capacity Information section to determine the required external relief valve capacity.

Table 4. Type 627R Internal Relief Performance⁽¹⁾

OUTLET PRESSURE RANGE, SPRING PART NUMBER AND COLOR CODE	OUTLET PRESSURE SETTING ⁽²⁾		MAXIMUM ALLOWABLE DOWNSTREAM SYSTEM PRESSURE		MAXIMUM INLET PRESSURE TO KEEP MAXIMUM ALLOWABLE DOWNSTREAM SYSTEM PRESSURE FROM BEING EXCEEDED ⁽³⁾											
					Orifice Size, In. / mm											
					3/32 / 2.4		1/8 / 3.2		3/16 / 4.8		1/4 / 6.4		3/8 / 9.5		1/2 / 13	
	psig	bar	psig	bar	psig	bar	psig	bar	psig	bar	psig	bar	psig	bar		
5 to 20 psig / 0.34 to 1.4 bar 10B3076X012 Yellow	10	0.69	60	4.1	1250	86.2	740	51.0	320	22.1	190	13.1	95	6.6	75	5.2
			100	6.9	2000	138	1500	103	620	42.7	390	26.9	180	12.4	130	9.0
			125	8.6	2000	138	1900	131	830	57.2	480	33.1	220	15.2	160	11.0
			175	12.1	2000	138	2000	138	1100	75.8	670	46.2	320	22.1	220	15.2
			200	13.8	2000	138	2000	138	1300	89.6	770	53.1	360	24.8	260	17.9
	250	17.2	2000	138	2000	138	1600	110	960	66.2	450	31.0	320	22.1		
	15	1.0	60	4.1	1000	69.0	620	42.7	260	17.9	170	11.7	90	6.2	70	4.8
			100	6.9	2000	138	1400	96.5	610	42.1	370	25.5	170	11.7	130	9.0
			125	8.6	2000	138	1900	131	810	55.8	480	33.1	220	15.2	160	11.0
			175	12.1	2000	138	2000	138	1100	75.8	670	46.2	320	22.1	220	15.2
			200	13.8	2000	138	2000	138	1300	89.6	770	53.1	360	24.8	260	17.9
	250	17.2	2000	138	2000	138	1600	110	960	66.2	450	31.0	320	22.1		
	20	1.4	60	4.1	850	58.6	490	33.8	210	14.5	130	9.0	80	5.5	65	4.5
			100	6.9	2000	138	1300	89.6	600	41.4	360	24.8	170	11.7	120	8.3
			125	8.6	2000	138	1800	124	800	55.2	480	33.1	220	15.2	160	11.0
175			12.1	2000	138	2000	138	1100	75.8	670	46.2	320	22.1	220	15.2	
200			13.8	2000	138	2000	138	1300	89.6	770	53.1	360	24.8	260	17.9	
250	17.2	2000	138	2000	138	1600	110	960	66.2	450	31.0	320	22.1			
15 to 40 psig / 1.0 to 2.8 bar 10B3077X012 Green	15	1.0	60	4.1	1000	69.0	380	26.2	210	14.5	130	9.0	80	5.5	65	4.5
			100	6.9	2000	138	1300	89.6	590	40.7	350	24.1	170	11.7	120	8.3
			125	8.6	2000	138	1800	124	800	55.2	470	32.4	220	15.2	160	11.0
			175	12.1	2000	138	2000	138	1100	75.8	640	44.1	320	22.1	220	15.2
			200	13.8	2000	138	2000	138	1300	89.6	780	53.8	370	25.5	260	17.9
	250	17.2	2000	138	2000	138	1600	110	960	66.2	450	31.0	320	22.1		
	20	1.4	60	4.1	630	43.4	200	13.8	150	10.3	100	6.9	70	4.8	65	4.5
			100	6.9	2000	138	1200	82.7	550	37.9	330	22.8	160	11.0	120	8.3
			125	8.6	2000	138	1700	117	760	52.4	450	31.1	210	14.5	160	11.0
			175	12.1	2000	138	2000	138	1100	75.8	630	43.4	320	22.1	220	15.2
			200	13.8	2000	138	2000	138	1300	89.6	770	53.1	360	24.8	260	17.9
	250	17.2	2000	138	2000	138	1600	110	960	66.2	450	31.0	320	22.1		
	30	2.1	100	6.9	2000	138	950	65.5	450	31.1	260	17.9	140	9.7	110	7.6
			125	8.6	2000	138	1500	103	670	46.2	400	27.6	190	13.1	150	10.3
			175	12.1	2000	138	2000	138	1000	69.0	610	42.1	300	20.7	220	15.2
200			13.8	2000	138	2000	138	1200	82.7	760	52.4	360	24.8	260	17.9	
250			17.2	2000	138	2000	138	1600	110	970	66.9	460	31.7	320	22.1	
40	2.8	100	6.9	1500	103	700	48.3	330	22.8	200	13.8	120	8.3	108	7.4	
		125	8.6	2000	138	1300	89.6	560	38.6	340	23.4	180	12.4	140	9.7	
		175	12.1	2000	138	1800	124	1000	69.0	550	37.9	290	20.0	220	15.2	
		200	13.8	2000	138	2000	138	1200	82.7	730	50.3	350	24.1	250	17.2	
		250	17.2	2000	138	2000	138	1600	110	970	66.9	460	31.7	320	22.1	
35 to 80 psig / 2.4 to 5.5 bar 10B3078X012 Blue	40	2.8	125	8.6	2000	138	1100	75.8	500	34.5	300	20.7	170	11.7	140	9.7
			150	10.3	2000	138	1600	110	750	51.7	440	30.3	230	15.9	180	12.4
			175	12.1	2000	138	2000	138	980	67.6	580	40.0	290	20.0	220	15.2
			200	13.8	2000	138	2000	138	1200	82.7	720	49.6	340	23.4	250	17.2
			250	17.2	2000	138	2000	138	1600	110	940	64.8	450	31.0	320	22.1
	50	3.4	125	8.6	1400	96.5	820	56.5	400	27.6	230	15.9	150	10.3	140	9.7
			150	10.3	2000	138	1400	96.5	650	44.8	370	25.5	210	14.5	170	11.7
			175	12.1	2000	138	1900	131	700	48.3	530	36.5	270	18.6	210	14.5
			200	13.8	2000	138	2000	138	1100	75.8	670	46.2	330	22.8	240	16.5
			250	17.2	2000	138	2000	138	1500	103	920	63.4	430	29.6	320	22.1
	60	4.1	125	8.6	900	62.1	450	31.0	270	18.6	190	13.1	140	9.7	130	9.0
			150	10.3	1700	117	1100	75.8	540	37.2	300	20.7	190	13.1	160	11.0
			175	12.1	2000	138	1700	117	780	53.8	470	32.4	250	17.2	200	13.8
			200	13.8	2000	138	2000	138	1000	69.0	610	42.1	310	21.4	230	15.9
			250	17.2	2000	138	2000	138	1400	96.5	880	60.7	420	29.0	310	21.4
70	4.8	150	10.3	1200	82.7	850	58.6	430	29.6	250	17.2	170	11.7	160	11.0	
		175	12.1	2000	138	1400	96.5	670	46.2	400	27.6	230	15.9	190	13.1	
		200	13.8	2000	138	2000	138	920	63.4	550	37.9	280	19.3	230	15.9	
		250	17.2	2000	138	2000	138	1300	89.6	830	57.2	400	27.6	310	21.4	
		150	10.3	800	55.2	500	34.5	300	20.7	200	13.8	160	11.0	150	10.3	
80	5.5	175	12.1	1500	103	1200	82.7	550	37.9	330	22.8	210	14.5	190	13.1	
		200	13.8	2000	138	1700	117	800	55.2	480	33.1	270	18.6	220	15.2	
		250	17.2	2000	138	2000	138	1200	82.7	770	53.1	390	26.9	300	20.7	
		175	12.1	1900	131	600	41.4	400	27.6	260	17.9	200	13.8	175	12.1	
		200	13.8	2000	138	1200	82.7	630	43.4	380	26.2	250	17.2	210	14.5	
250	17.2	2000	138	2000	138	1100	75.8	680	46.9	360	24.8	290	20.0			
70 to 150 psig / 4.8 to 10.3 bar 10B3079X012 Red	70	4.8	175	12.1	1400	96.5	250	17.2	240	16.5	200	13.8	190	13.1	175	12.1
			200	13.8	2000	138	960	66.2	520	35.9	330	22.8	240	16.5	210	14.5
	80	5.5	250	17.2	2000	138	2000	138	1000	69.0	620	42.7	350	24.1	280	19.3
			200	13.8	1500	103	250	17.2	240	16.5	230	15.9	210	14.5	210	14.5
			250	17.2	2000	138	1600	110	770	53.1	520	35.9	320	22.1	270	18.6
125	8.6	250	17.2	2000	138	1000	69.0	500	34.5	390	26.9	290	20.0	260	17.9	
150	10.3	250	17.2	1200	82.7	260	17.9	260	17.9	260	17.9	260	17.9	260	17.9	

— Shaded areas indicate maximum inlet pressures allowed during system malfunction only. Table 1 gives the maximum inlet pressure for normal regulator operation.

1. The internal relief performance values are obtained by removing the disk assembly.

2. For inlet pressures in excess of 1000 psig / 69.0 bar, refer to the maximum body and disk pressure ratings in the Specifications section.

3. For pressure settings under 10 psig / 0.69 bar, inlet pressure should be limited to approximately 100 psig / 6.9 bar so the setpoint adjustment can be obtained.

627 Series

Table 5. Type 627LR Internal Relief Performance⁽¹⁾

OUTLET PRESSURE RANGE, SPRING PART NUMBER AND COLOR CODE	OUTLET PRESSURE SETTING		MAXIMUM ALLOWABLE DOWNSTREAM SYSTEM PRESSURE		MAXIMUM INLET PRESSURE TO KEEP MAXIMUM ALLOWABLE DOWNSTREAM SYSTEM PRESSURE FROM BEING EXCEEDED ⁽²⁾							
					Orifice Size, In. / mm							
					3/32 / 2.4		1/8 / 3.2		3/16 / 4.8		1/4 / 6.4	
	psig	bar	psig	bar	psig	bar	psig	bar	psig	bar	psig	bar
15 to 40 psig / 1.03 to 2.8 bar	30	2.1	55	3.8	500	34.5	270	18.6	110	7.6	80	5.5
			60	4.1	850	58.6	480	33.1	200	13.8	120	8.3
			66	4.5	1000	69.0	660	45.5	290	20.0	175	12.1
10B3077X012 Green	40	2.8	66	4.5	380	26.2	190	13.1	85	5.9	80	5.5
			70	4.8	700	48.3	370	25.5	150	10.3	115	7.9
			75	5.2	1000	69.0	560	38.6	240	16.5	160	11.0

1. The internal relief performance values are obtained by removing the disk assembly.
 2. For inlet pressures in excess of 1000 psig / 69.0 bar, refer to the maximum body and disk pressure ratings in the Specifications section.

Capacity Information

Note

Flow capacities are laboratory verified; therefore, regulators may be sized for 100% of the published flow capacities. It is not necessary to reduce published capacities.

Tables 6 to 15 show the natural gas regulating capacities of the Type 627 at selected inlet and outlet pressure settings. Flows are in thousands of SCFH at 60°F and 14.7 psia and in thousands of Nm³/h at 0°C and 1.01325 bar of 0.6 specific gravity natural gas.

To determine equivalent capacities for air, propane, butane or nitrogen, multiply the capacity by the following appropriate conversion factor: 0.775 for air, 0.628 for propane, 0.548 for butane or 0.789 for nitrogen. For gases of other specific gravities, multiply the given capacity by 0.775 and divide by the square root of the appropriate specific gravity.

To find wide-open flow capacities for relief sizing at any inlet pressure, perform one of the following procedures. Then, if necessary, convert using the factors provided above.

For critical pressure drops (absolute outlet pressure equal to or less than one-half of absolute inlet pressure), use the following formula:

$$Q = (P_1)(C_g)(1.29)$$

where,

- Q = gas flow rate, SCFH
- P₁ = absolute inlet pressure, psia (P₁ gauge + 14.7)
- C_g = regulating or wide-open gas sizing coefficient from Table 16 or 17

Then, if capacity is desired in normal cubic meters per hour at 0°C and 1.01325 bar, multiply SCFH by 0.0268.

For pressure drops lower than critical (absolute outlet pressure greater than one-half of absolute inlet pressure).

$$Q = \sqrt{\frac{520}{GT}} C_g P_1 \text{SIN} \left(\frac{3417}{C_1} \sqrt{\frac{\Delta P}{P_1}} \right) \text{DEG}$$

where,

- Q = gas flow rate, SCFH
- G = gas specific gravity of the gas
- T = absolute temperature of gas at inlet, °Rankine
- C_g = gas sizing coefficient
- P₁ = absolute inlet pressure, psia (P₁ gauge + 14.7)
- C₁ = flow coefficient
- ΔP = pressure drop across the regulator, psi

Then, if capacity is desired in normal cubic meters per hour (Nm³/h) at 0°C and 1.01325 bar, multiply SCFH by 0.0268.

Table 6. Types 627, 627M and 627MR Capacities for 3/4 NPT Body Size⁽¹⁾

OUTLET PRESSURE RANGE, SPRING PART NUMBER AND COLOR CODE	OUTLET PRESSURE SETTING ⁽²⁾ , psig / bar	INLET PRESSURE, psig / bar	CAPACITIES IN SCFH / Nm ³ /h OF 0.6 SPECIFIC GRAVITY NATURAL GAS					
			Orifice Size, In. / mm					
			3/32 / 2.4	1/8 / 3.2	3/16 / 4.8	1/4 / 6.4	3/8 / 9.5	1/2 / 13
5 to 20 psig / 0.34 to 1.4 bar 10B3076X012 Yellow	5 / 0.34 ⁽³⁾	10 / 0.69	170 / 4.56	320 / 8.58	700 / 18.8	1060 / 28.4	1540 / 41.3	1900 / 50.9
		15 / 1.0	240 / 6.43	330 / 8.84	810 / 21.7	1300 / 34.8	2150 / 57.6	3350 / 89.8
		20 / 1.4	290 / 7.77	460 / 12.3	1140 / 30.6	1800 / 48.2	3050 / 81.7	4350 / 117
		30 / 2.1	380 / 10.2	610 / 16.3	1530 / 41.0	2490 / 66.7	3880 / 104	6850 / 184
		60 / 4.1	640 / 17.2	1170 / 31.4	2550 / 68.3	4240 / 114	6270 / 168	7370 / 198
		75 / 5.2	770 / 20.6	1410 / 37.8	3020 / 80.9	5100 / 137	6620 / 177	7700 / 206
	10 / 0.69	100 / 6.9	990 / 26.5	1800 / 48.2	3800 / 102	5980 / 160	7440 / 199	7900 / 212
		15 / 1.0	210 / 5.63	320 / 8.6	800 / 21.4	1290 / 34.6	2100 / 56.3	3300 / 88.4
		20 / 1.4	280 / 7.50	455 / 12.2	1130 / 30.3	1790 / 48.0	3000 / 80.4	4300 / 115
		30 / 2.1	380 / 10.2	610 / 16.3	1530 / 41.0	2480 / 66.5	3860 / 103	6830 / 183
		60 / 4.1	640 / 17.2	1170 / 31.4	2550 / 68.3	4240 / 114	6270 / 168	7370 / 198
		75 / 5.2	770 / 20.6	1410 / 37.8	3020 / 80.9	5100 / 137	6620 / 177	7700 / 206
		100 / 6.9	990 / 26.5	1800 / 48.2	3800 / 102	5980 / 160	7440 / 199	7900 / 212
		150 / 10.3	1420 / 38.1	2580 / 69.1	5700 / 153	7130 / 191	8180 / 219	8200 / 220
		200 / 13.8	1850 / 49.6	3370 / 90.3	6970 / 187	7250 / 194	8200 / 220	8300 / 222
		300 / 20.7	2700 / 72.4	4910 / 132	8000 / 214	8050 / 216	8250 / 221	
		500 / 34.5	4010 / 107	8090 / 217	8060 / 216	8100 / 217		
		750 / 51.7	4400 / 118	8930 / 239	8950 / 240			
		1000 / 69.0	4450 / 119	10,300 / 276				
		1250 / 86.2	4540 / 122					
	1500 / 103	4880 / 131						
	1750 / 121	5230 / 140						
	2000 / 138	5900 / 158						
	20 / 1.4	30 / 2.1	350 / 9.38	620 / 16.6	1400 / 37.5	2490 / 66.7	4360 / 117	6290 / 169
		50 / 3.4	550 / 14.7	1000 / 26.8	2280 / 61.1	4010 / 107	7870 / 211	8500 / 228
		60 / 4.1	640 / 17.2	1170 / 31.4	2640 / 70.8	4680 / 125	8340 / 224	8940 / 240
		100 / 6.9	990 / 26.5	1800 / 48.2	3980 / 107	7220 / 193	11,500 / 308	12,600 / 338
		150 / 10.3	1420 / 38.1	2580 / 69.1	5850 / 157	10,400 / 279	12,100 / 324	13,100 / 351
		200 / 13.8	1850 / 49.6	3370 / 90.3	7340 / 197	12,000 / 322	13,200 / 354	13,700 / 367
		300 / 20.7	2700 / 72.4	4910 / 132	11,200 / 300	13,000 / 348	15,600 / 418	
		500 / 34.5	4400 / 118	8090 / 217	18,300 / 490	15,100 / 405		
		750 / 51.7	6600 / 177	12,000 / 322	14,200 / 381			
		1000 / 69.0	7300 / 196	14,600 / 391				
		1250 / 86.2	7500 / 201					
		1500 / 103	7800 / 209					
		1750 / 121	8400 / 225					
2000 / 138		8600 / 230						
15 to 40 psig / 1.0 to 2.8 bar 10B3077X012 Green	40 / 2.8	60 / 4.1	610 / 16.3	1090 / 29.2	2530 / 67.8	4350 / 117	8140 / 218	9420 / 252
		75 / 5.2	760 / 20.4	1370 / 36.7	3080 / 82.5	5510 / 148	10,300 / 276	13,600 / 364
		100 / 6.9	990 / 26.5	1790 / 48.0	4070 / 109	7220 / 193	13,200 / 354	15,300 / 410
		150 / 10.3	1420 / 38.1	2580 / 69.1	5850 / 157	10,400 / 279	17,400 / 466	18,200 / 488
		200 / 13.8	1850 / 49.6	3370 / 90.3	7630 / 204	13,500 / 362	18,000 / 482	18,500 / 496
		300 / 20.7	2700 / 72.4	4910 / 132	11,200 / 300	18,500 / 496	20,000 / 536	20,700 / 555
		500 / 34.5	4400 / 118	8090 / 217	18,300 / 490	24,000 / 643	27,000 / 724	
		750 / 51.7	6600 / 177	12,000 / 322	23,000 / 616	24,200 / 649		
		1000 / 69.0	8700 / 233	16,000 / 429	24,400 / 654			
		1250 / 86.2	11,000 / 295	18,000 / 482				
		1500 / 103	12,000 / 322	21,000 / 563				
		1750 / 121	13,000 / 348					
		2000 / 138	14,000 / 375					

— Blank areas indicate where maximum operating inlet pressure for a given orifice is exceeded.
 — Shaded areas indicate where a Type 627MR regulator should not be used because unbalanced forces can cause the internal relief valve to start-to-discharge during normal operation. Refer to Table 4.

- Capacity is based on 20% droop unless otherwise noted below.
- For pressure settings under 10 psig / 0.69 bar, inlet pressure should be limited to approximately 100 psig / 6.9 bar so the setpoint adjustment can be obtained.
- For 5 psig / 0.34 bar pressure setpoint the droop is 2 psig / 0.14 bar.

- continued -

627 Series

Table 6. Types 627, 627M and 627MR Capacities for 3/4 NPT Body Size⁽¹⁾ (continued)

OUTLET PRESSURE RANGE, SPRING PART NUMBER AND COLOR CODE	OUTLET PRESSURE SETTING, psig / bar	INLET PRESSURE, psig / bar	CAPACITIES IN SCFH / Nm ³ /h OF 0.6 SPECIFIC GRAVITY NATURAL GAS					
			Orifice Size, In. / mm					
			3/32 / 2.4	1/8 / 3.2	3/16 / 4.8	1/4 / 6.4	3/8 / 9.5	1/2 / 13
35 to 80 psig / 2.4 to 5.5 bar 10B3078X012 Blue	60 / 4.1	75 / 5.2	700 / 18.8	1230 / 33.0	2760 / 74.0	4750 / 127	8620 / 231	15,200 / 407
		100 / 6.9	970 / 26.0	1740 / 46.6	4010 / 107	6990 / 187	12,800 / 343	17,300 / 464
		150 / 10.3	1420 / 38.1	2580 / 69.1	5850 / 157	10,300 / 276	18,600 / 498	23,000 / 616
		200 / 13.8	1850 / 49.6	3370 / 90.3	7630 / 204	13,500 / 362	21,600 / 579	27,400 / 734
		300 / 20.7	2700 / 72.4	4910 / 132	11,200 / 300	19,800 / 531	26,100 / 699	30,100 / 807
		500 / 34.5	4400 / 118	8090 / 217	18,300 / 490	28,100 / 753	28,900 / 775	33,400 / 895
		750 / 51.7	6600 / 177	12,000 / 322	26,300 / 705	30,000 / 804	37,000 / 992	45,000 / 1206
		1000 / 69.0	8700 / 233	16,000 / 429	30,000 / 804	31,200 / 836	37,400 / 1002	
		1250 / 86.2	11,000 / 295	19,000 / 509	31,600 / 847	34,000 / 911		
		1500 / 103	13,000 / 348	22,000 / 590	30,400 / 815	36,000 / 965		
	1750 / 121	15,000 / 402	25,000 / 670	34,000 / 911				
	2000 / 138	17,000 / 456	28,000 / 750					
	80 / 5.5	100 / 6.9	900 / 24.1	1600 / 42.9	3750 / 101	6490 / 174	12,200 / 327	17,300 / 464
		150 / 10.3	1410 / 37.8	2580 / 69.1	5850 / 157	10,200 / 273	19,600 / 525	25,700 / 689
		200 / 13.8	1850 / 49.6	3370 / 90.3	7630 / 204	13,500 / 362	25,400 / 681	29,300 / 785
		300 / 20.7	2700 / 72.4	4910 / 132	11,200 / 300	19,800 / 531	32,700 / 876	33,500 / 898
		500 / 34.5	4400 / 118	8090 / 217	18,300 / 490	31,900 / 855	36,000 / 965	36,700 / 984
		750 / 51.7	6600 / 177	12,000 / 322	27,200 / 729	35,000 / 938	44,000 / 1179	46,000 / 1233
		1000 / 69.0	8700 / 233	16,000 / 429	36,100 / 967	38,000 / 1018	56,200 / 1506	
		1250 / 86.2	11,000 / 295	19,000 / 509	37,000 / 992	40,000 / 1072		
1500 / 103		13,000 / 348	22,000 / 590	38,000 / 1018	44,000 / 1179			
1750 / 121		15,000 / 402	25,000 / 670	42,000 / 1126				
2000 / 138	17,000 / 456	28,000 / 750						
70 to 150 psig / 4.8 to 10.3 bar 10B3079X012 Red	100 / 6.9	150 / 10.3	1170 / 31.4	2510 / 67.3	5540 / 148	8710 / 233	16,000 / 429	20,300 / 544
		200 / 13.8	1850 / 49.6	3370 / 90.3	7630 / 204	12,000 / 322	21,300 / 571	25,700 / 689
		300 / 20.7	2700 / 72.4	4910 / 132	11,200 / 300	19,400 / 520	30,000 / 804	31,700 / 850
		500 / 34.5	4400 / 118	8090 / 217	18,300 / 490	31,800 / 852	39,000 / 1045	39,200 / 1051
		750 / 51.7	6600 / 177	12,000 / 322	27,200 / 729	39,000 / 1045	39,200 / 1051	45,900 / 1230
		1000 / 69.0	8700 / 233	16,000 / 429	36,100 / 967	40,000 / 1072	40,500 / 1085	
		1250 / 86.2	11,000 / 295	19,000 / 509	39,000 / 1045	40,500 / 1085	41,000 / 1099	
		1500 / 103	13,000 / 348	22,000 / 590	43,000 / 1152	44,000 / 1179		
		1750 / 121	15,000 / 402	25,000 / 670	45,000 / 1206	47,000 / 1260		
		2000 / 138	17,000 / 456	28,000 / 750	46,000 / 1233			
	125 / 8.6	150 / 10.3	1250 / 33.5	2340 / 62.7	5340 / 143	9130 / 245	15,700 / 421	20,800 / 557
		200 / 13.8	1830 / 49.0	3320 / 89.0	7550 / 202	13,160 / 353	22,500 / 603	28,600 / 766
		300 / 20.7	2700 / 72.4	4910 / 132	11,200 / 300	19,800 / 531	32,700 / 876	38,000 / 1018
		500 / 34.5	4400 / 118	8090 / 217	18,300 / 490	32,500 / 871	43,800 / 1174	51,700 / 1386
		750 / 51.7	6600 / 177	12,000 / 322	27,200 / 729	48,300 / 1294	49,900 / 1337	71,400 / 1914
		1000 / 69.0	8700 / 233	16,000 / 429	36,100 / 967	50,000 / 1340	52,900 / 1418	72,000 / 1930
		1250 / 86.2	11,000 / 295	19,000 / 509	45,000 / 1206	53,000 / 1420	58,000 / 1554	
		1500 / 103	13,000 / 348	22,000 / 590	51,000 / 1367	56,000 / 1501		
		1750 / 121	15,000 / 402	25,000 / 670	52,000 / 1394	60,000 / 1608		
		2000 / 138	17,000 / 456	28,000 / 750	53,000 / 1420			
	150 / 10.3	200 / 13.8	1760 / 47.2	3200 / 85.8	7290 / 195	12,500 / 335	21,400 / 574	30,600 / 820
		300 / 20.7	2700 / 72.4	4910 / 132	11,200 / 300	17,200 / 461	34,700 / 930	46,000 / 1233
		500 / 34.5	4400 / 118	8090 / 217	18,300 / 490	32,500 / 871	48,900 / 1311	59,700 / 1600
		750 / 51.7	6600 / 177	12,000 / 322	27,200 / 729	48,300 / 1294	59,000 / 1581	72,000 / 1930
		1000 / 69.0	8700 / 233	16,000 / 429	36,100 / 967	64,100 / 1718	81,100 / 2173	85,000 / 2278
		1250 / 86.2	11,000 / 295	19,000 / 509	45,000 / 1206	68,000 / 1822	90,000 / 2412	
		1500 / 103	13,000 / 348	22,000 / 590	54,000 / 1447	72,000 / 1930		
		1750 / 121	15,000 / 402	25,000 / 670	63,000 / 1688	77,000 / 2064		
	2000 / 138	17,000 / 456	28,000 / 750	71,000 / 1903				

Blank areas indicate where maximum operating inlet pressure for a given orifice is exceeded.
 Shaded areas indicate where a Type 627MR regulator should not be used because unbalanced forces can cause the internal relief valve to start-to-discharge during normal operation. Refer to Table 4.

1. Capacity is based on 20% droop unless otherwise noted below.

Table 7. Types 627, 627M, 627MR, 627BM and 627BMR, 627OSX and 627BMOSX Capacities for NPS 1 / DN 25 Body Size⁽¹⁾⁽⁴⁾

OUTLET PRESSURE RANGE, SPRING PART NUMBER AND COLOR CODE	OUTLET PRESSURE SETTING ⁽²⁾ , psig / bar	INLET PRESSURE, psig / bar	CAPACITIES IN SCFH / Nm ³ /h OF 0.6 SPECIFIC GRAVITY NATURAL GAS						
			Orifice Size, In. / mm						
			For All Types Except Types 627BM and 627BMR						For Types 627BM and 627BMR only
			3/32 / 2.4	1/8 / 3.2	3/16 / 4.8	1/4 / 6.4	3/8 / 9.5	1/2 / 13	9/16 / 14.3
5 to 20 psig / 0.34 to 1.4 bar 10B3076X012 Yellow	5 / 0.34 ⁽³⁾	10 / 0.69	170 / 4.6	330 / 8.8	710 / 19.0	1100 / 29.5	1900 / 50.9	2500 / 67.0	1570 / 42.1
		15 / 1.0	240 / 6.4	390 / 10.5	890 / 23.9	1600 / 42.9	2500 / 67.0	3350 / 89.8	1780 / 47.7
		20 / 1.4	290 / 7.8	500 / 13.4	1160 / 31.1	2060 / 55.2	3400 / 91.1	4450 / 119	1980 / 53.0
		30 / 2.1	380 / 10.2	670 / 18.0	1560 / 41.8	2800 / 75.0	4750 / 127	6900 / 185	2940 / 78.8
		60 / 4.1	640 / 17.2	1170 / 31.4	2600 / 69.7	4710 / 126	8140 / 218	13,700 / 367	5790 / 155
		75 / 5.2	770 / 20.6	1410 / 37.8	3150 / 84.4	5710 / 153	9790 / 262	14,500 / 389	8020 / 215
	10 / 0.7	100 / 6.9	990 / 26.5	1800 / 48.2	4070 / 109	7310 / 196	12,500 / 335	16,000 / 429	11,700 / 313
		15 / 1.0	210 / 5.6	375 / 10.1	880 / 23.6	1590 / 42.6	2480 / 66.5	3300 / 88.4	2880 / 77.2
		20 / 1.4	280 / 7.5	490 / 13.1	1150 / 30.8	2050 / 54.9	3380 / 90.6	4410 / 118	3750 / 100
		30 / 2.1	380 / 10.2	670 / 18.0	1560 / 41.8	2800 / 75.0	4720 / 126	6840 / 183	5490 / 147
		60 / 4.1	640 / 17.2	1170 / 31.4	2600 / 69.7	4710 / 126	8140 / 218	13,700 / 367	10,700 / 287
		75 / 5.2	770 / 20.6	1410 / 37.8	3150 / 84.4	5710 / 153	9790 / 262	14,500 / 389	13,500 / 362
		100 / 6.9	990 / 26.5	1800 / 48.2	4070 / 109	7310 / 196	12,500 / 335	16,000 / 429	18,300 / 490
		150 / 10.3	1420 / 38.1	2580 / 69.1	5850 / 157	10,500 / 281	17,000 / 456	18,000 / 482	27,900 / 747
		200 / 13.8	1850 / 49.6	3370 / 90.3	7630 / 204	13,700 / 367	18,000 / 482	18,500 / 496	28,700 / 769
		300 / 20.7	2700 / 72.4	4910 / 132	11,200 / 300	19,800 / 531	20,000 / 536		30,400 / 814
		500 / 34.5	4400 / 118	8090 / 217	15,700 / 421	20,000 / 536			31,900 / 855
		750 / 51.7	5400 / 145	12,000 / 322	18,000 / 482				32,100 / 860
		1000 / 69.0	5800 / 155	14,000 / 375					32,400 / 868
		1250 / 86.2	6300 / 169						33,100 / 887
	1500 / 103	6600 / 177						33,800 / 906	
	1750 / 121	6800 / 182							
	2000 / 138	7600 / 204							
	20 / 1.4	30 / 2.1	350 / 9.4	620 / 16.6	1450 / 38.9	2580 / 69.1	4360 / 117	6290 / 169	6900 / 185
		50 / 3.4	550 / 14.7	1000 / 26.8	2280 / 61.1	4090 / 110	7870 / 211	14,100 / 378	12,500 / 335
		60 / 4.1	640 / 17.2	1170 / 31.4	2640 / 70.8	4750 / 127	9690 / 260	14,500 / 389	15,400 / 413
		100 / 6.9	990 / 26.5	1800 / 48.2	4070 / 109	7310 / 196	13,900 / 373	23,300 / 624	26,000 / 697
		150 / 10.3	1420 / 38.1	2580 / 69.1	5850 / 157	10,500 / 281	17,700 / 474	34,200 / 917	39,300 / 1053
		200 / 13.8	1850 / 49.6	3370 / 90.3	7630 / 204	13,700 / 367	26,600 / 713	39,100 / 1048	40,700 / 1090
		300 / 20.7	2700 / 72.4	4910 / 132	11,200 / 300	20,100 / 539	37,000 / 992		43,600 / 1168
		500 / 34.5	4400 / 118	8090 / 217	18,300 / 490	32,900 / 882			45,600 / 1222
		750 / 51.7	6600 / 177	12,000 / 322	23,600 / 632				46,100 / 1235
		1000 / 69.0	8900 / 239	16,000 / 429					46,500 / 1246
		1250 / 86.2	10,000 / 268						46,600 / 1248
		1500 / 103	10,400 / 279						46,600 / 1248
		1750 / 121	12,000 / 322						
2000 / 138		14,000 / 375							
15 to 40 psig / 1.0 to 2.8 bar 10B3077X012 Green	40 / 2.8	60 / 4.1	610 / 16.3	1090 / 29.2	2530 / 67.8	4510 / 121	9290 / 249	9420 / 252	14,400 / 386
		75 / 5.2	760 / 20.4	1370 / 36.7	3080 / 82.5	5640 / 151	10,800 / 289	16,500 / 442	18,800 / 504
		100 / 6.9	990 / 26.5	1790 / 48.0	4070 / 109	7310 / 196	14,700 / 394	21,900 / 587	26,000 / 697
		150 / 10.3	1420 / 38.1	2580 / 69.1	5850 / 157	10,500 / 281	20,500 / 549	34,500 / 925	40,500 / 1085
		200 / 13.8	1850 / 49.6	3370 / 90.3	7630 / 204	13,700 / 367	27,100 / 726	46,400 / 1244	48,100 / 1289
		300 / 20.7	2700 / 72.4	4910 / 132	11,200 / 300	20,100 / 539	40,100 / 1075	67,100 / 1798	63,400 / 1698
		500 / 34.5	4400 / 118	8090 / 217	18,300 / 490	32,900 / 882	63,900 / 1713		66,800 / 1790
		750 / 51.7	6600 / 177	12,000 / 322	27,200 / 729	39,400 / 1056			69,000 / 1849
		1000 / 69.0	8700 / 233	16,000 / 429	36,100 / 967				71,100 / 1905
		1250 / 86.2	11,000 / 295	19,000 / 509					71,500 / 1915
		1500 / 103	13,000 / 348	22,000 / 590					71,900 / 1926
		1750 / 121	15,000 / 402						
		2000 / 138	17,000 / 456						

— Blank areas indicate where maximum operating inlet pressure for a given orifice is exceeded.
 — Shaded areas indicate where a Type 627MR regulator should not be used because unbalanced forces can cause the internal relief valve to start-to-discharge during normal operation. Refer to Table 4.
 1. Capacity is based on 20% droop unless otherwise noted below.
 2. For pressure settings under 10 psig / 0.69 bar, inlet pressure should be limited to approximately 100 psig / 6.9 bar so the setpoint adjustment can be obtained.
 3. For 5 psig / 0.34 bar pressure setpoint the droop is 2 psig / 0.14 bar.
 4. Capacity is reduced by 10% for Types 627OSX and 627BMOSX.

- continued -

627 Series

Table 7. Types 627, 627M, 627MR, 627BM and 627BMR, 627OSX and 627BMOSX Capacities for NPS 1 / DN 25 Body Size⁽¹⁾⁽²⁾ (continued)

OUTLET PRESSURE RANGE, SPRING PART NUMBER AND COLOR CODE	OUTLET PRESSURE SETTING, psig / bar	INLET PRESSURE, psig / bar	CAPACITIES IN SCFH / Nm ³ /h OF 0.6 SPECIFIC GRAVITY NATURAL GAS							
			Orifice Size, In. / mm							
			For All Types Except Types 627BM and 627BMR							For Types 627BM and 627BMR only
			3/32 / 2.4	1/8 / 3.2	3/16 / 4.8	1/4 / 6.4	3/8 / 9.5	1/2 / 13	9/16 / 14.3	
35 to 80 psig / 2.4 to 5.5 bar 10B3078X012 Blue	60 / 4.1	75 / 5.2	700 / 18.8	1230 / 33.0	2760 / 74.0	4880 / 131	8630 / 231	16,100 / 431	15,200 / 407	
		100 / 6.9	970 / 26.0	1740 / 46.6	4010 / 107	7000 / 188	13,000 / 348	19,300 / 517	21,500 / 576	
		150 / 10.3	1420 / 38.1	2580 / 69.1	5850 / 157	10,500 / 281	18,900 / 507	32,800 / 879	34,100 / 914	
		200 / 13.8	1850 / 49.6	3370 / 90.3	7630 / 204	13,700 / 367	24,000 / 643	42,200 / 1131	46,600 / 1248	
		300 / 20.7	2700 / 72.4	4910 / 132	11,200 / 300	20,100 / 539	32,500 / 871	69,100 / 1852	69,900 / 1873	
		500 / 34.5	4400 / 118	8090 / 217	18,300 / 490	32,900 / 882	64,000 / 1715	94,300 / 2527	86,700 / 2323	
		750 / 51.7	6600 / 177	12,000 / 322	27,200 / 729	43,380 / 1163	66,000 / 1769	130,000 / 3484	90,800 / 2433	
		1000 / 69.0	8700 / 233	16,000 / 429	36,100 / 967	50,300 / 1348	67,700 / 1814		95,000 / 2545	
		1250 / 86.2	11,000 / 295	19,000 / 509	45,000 / 1206	57,000 / 1528			94,400 / 2529	
		1500 / 103	13,000 / 348	22,000 / 590	54,000 / 1447	63,000 / 1688			93,700 / 2510	
	1750 / 121	15,000 / 402	25,000 / 670	63,000 / 1688						
	2000 / 138	17,000 / 456	28,000 / 750							
	80 / 5.5	100 / 6.9	900 / 24.1	1600 / 42.9	3750 / 101	6650 / 178	12,200 / 327	18,600 / 498	15,200 / 407	
		150 / 10.3	1410 / 37.8	2580 / 69.1	5850 / 157	10,500 / 281	21,100 / 565	33,600 / 900	30,900 / 828	
		200 / 13.8	1850 / 49.6	3370 / 90.3	7630 / 204	13,700 / 367	28,400 / 761	44,100 / 1182	46,600 / 1248	
		300 / 20.7	2700 / 72.4	4910 / 132	11,200 / 300	20,100 / 539	43,300 / 1160	75,400 / 2021	69,900 / 1873	
		500 / 34.5	4400 / 118	8090 / 217	18,300 / 490	32,900 / 882	71,600 / 1919	110,000 / 2948	93,700 / 2510	
		750 / 51.7	6600 / 177	12,000 / 322	27,200 / 729	48,900 / 1311	105,500 / 2827	135,000 / 3618	105,400 / 2824	
		1000 / 69.0	8700 / 233	16,000 / 429	36,100 / 967	64,900 / 1739	118,000 / 3162		117,100 / 3137	
1250 / 86.2		11,000 / 295	19,000 / 509	45,000 / 1206	80,000 / 2144			118,800 / 3183		
1500 / 103		13,000 / 348	22,000 / 590	54,000 / 1447	96,000 / 2573			120,500 / 3228		
1750 / 121		15,000 / 402	25,000 / 670	63,000 / 1688						
2000 / 138	17,000 / 456	28,000 / 750								
70 to 150 psig / 4.8 to 10.3 bar 10B3079X012 Red	100 / 6.9	150 / 10.3	1170 / 31.4	2510 / 67.3	5540 / 148	8710 / 233	16,000 / 429	24,000 / 643	26,200 / 702	
		200 / 13.8	1850 / 49.6	3370 / 90.3	7630 / 204	12,000 / 322	21,300 / 571	34,100 / 914	37,000 / 991	
		300 / 20.7	2700 / 72.4	4910 / 132	11,200 / 300	19,400 / 520	30,100 / 807	53,200 / 1426	58,600 / 1570	
		500 / 34.5	4400 / 118	8090 / 217	18,300 / 490	31,800 / 852	66,500 / 1782	83,900 / 2249	95,300 / 2553	
		750 / 51.7	6600 / 177	12,000 / 322	27,200 / 729	47,300 / 1268	95,300 / 2554	117,000 / 3136	116,700 / 3126	
		1000 / 69.0	8700 / 233	16,000 / 429	36,100 / 967	59,700 / 1600	100,000 / 2680		138,200 / 3702	
		1250 / 86.2	11,000 / 295	19,000 / 509	45,000 / 1206	72,000 / 1930	114,000 / 3055		144,300 / 3866	
		1500 / 103	13,000 / 348	22,000 / 590	54,000 / 1447	86,000 / 2305			150,400 / 4029	
		1750 / 121	15,000 / 402	25,000 / 670	63,000 / 1688	95,000 / 2546				
		2000 / 138	17,000 / 456	28,000 / 750	71,000 / 1903					
	125 / 8.6	150 / 10.3	1250 / 33.5	2340 / 62.7	5340 / 143	9470 / 254	15,700 / 421	20,800 / 557	27,800 / 745	
		200 / 13.8	1830 / 49.0	3320 / 89.0	7550 / 202	13,400 / 359	28,100 / 753	32,800 / 879	40,400 / 1082	
		300 / 20.7	2700 / 72.4	4910 / 132	11,200 / 300	20,100 / 539	36,300 / 973	52,600 / 1410	65,500 / 1755	
		500 / 34.5	4400 / 118	8090 / 217	18,300 / 490	32,900 / 882	70,800 / 1897	109,000 / 2921	113,000 / 3027	
		750 / 51.7	6600 / 177	12,000 / 322	27,200 / 729	48,900 / 1311	104,000 / 2787	158,000 / 4234	137,900 / 3694	
		1000 / 69.0	8700 / 233	16,000 / 429	36,100 / 967	64,800 / 1737	138,000 / 3698	160,000 / 4288	162,700 / 4359	
		1250 / 86.2	11,000 / 295	19,000 / 509	45,000 / 1206	80,000 / 2144	145,000 / 3886		167,000 / 4474	
		1500 / 103	13,000 / 348	22,000 / 590	54,000 / 1447	96,000 / 2573			171,300 / 4589	
		1750 / 121	15,000 / 402	25,000 / 670	63,000 / 1688	112,000 / 3002				
		2000 / 138	17,000 / 456	28,000 / 750	71,000 / 1903					
	150 / 10.3	200 / 13.8	1760 / 47.2	3200 / 85.8	7290 / 195	12,900 / 346	21,400 / 574	33,600 / 900	43,200 / 1157	
		300 / 20.7	2700 / 72.4	4910 / 132	11,200 / 300	17,200 / 461	40,100 / 1075	55,900 / 1498	70,700 / 1894	
		500 / 34.5	4400 / 118	8090 / 217	18,300 / 490	32,900 / 882	70,300 / 1884	111,000 / 2975	122,200 / 3274	
		750 / 51.7	6600 / 177	12,000 / 322	27,200 / 729	48,900 / 1311	104,000 / 2787	160,000 / 4288	157,000 / 4206	
		1000 / 69.0	8700 / 233	16,000 / 429	36,100 / 967	64,800 / 1737	138,000 / 3698	162,000 / 4342	191,800 / 5138	
		1250 / 86.2	11,000 / 295	19,000 / 509	45,000 / 1206	80,000 / 2144	150,000 / 4020		196,800 / 5272	
		1500 / 103	13,000 / 348	22,000 / 590	54,000 / 1447	96,000 / 2573			201,900 / 5409	
		1750 / 121	15,000 / 402	25,000 / 670	63,000 / 1688	112,000 / 3002				
	2000 / 138	17,000 / 456	28,000 / 750	71,000 / 1903						

— Blank areas indicate where maximum operating inlet pressure for a given orifice is exceeded.
 — Shaded areas indicate where a Type 627MR regulator should not be used because unbalanced forces can cause the internal relief valve to start-to-discharge during normal operation. Refer to Table 4.
 1. Capacity is based on 20% droop unless otherwise noted below.
 2. Capacity is reduced by 10% for Types 627OSX and 627BMOSX.

Table 8. Type 627 Capacities for NPS 1-1/4 / DN 32 Body Size⁽¹⁾

OUTLET PRESSURE RANGE, SPRING PART NUMBER AND COLOR CODE	OUTLET PRESSURE SETTING ⁽²⁾ , psig / bar	INLET PRESSURE, psig / bar	CAPACITIES IN SCFH / Nm ³ /h OF 0.6 SPECIFIC GRAVITY NATURAL GAS						
			Orifice Size, In. / mm						
			3/32 / 2.4	1/8 / 3.2	3/16 / 4.8	1/4 / 6.4	3/8 / 9.5	1/2 / 13	
5 to 20 psig / 0.34 to 1.4 bar 10B3076X012 Yellow	5 / 0.34 ⁽³⁾	10 / 0.69	200 / 5.4	370 / 10.1	820 / 22.1	1010 / 27.2	1380 / 37.4	1790 / 48.4	
		15 / 1.0	270 / 7.3	450 / 12.2	1010 / 27.4	1280 / 34.6	1970 / 53.2	2340 / 63.2	
		20 / 1.4	300 / 8.1	530 / 14.4	1200 / 32.3	1620 / 43.6	2320 / 62.5	3220 / 86.8	
		30 / 2.1	370 / 10.2	670 / 18.1	1520 / 41	2100 / 56.6	3170 / 85.5	9420 / 253.6	
		60 / 4.1	620 / 16.7	940 / 25.3	2450 / 66.1	3270 / 88	6750 / 181.6	6080 / 163.6	
		75 / 5.2	730 / 19.7	1150 / 31.2	2700 / 72.8	3920 / 105.6	11000 / 298.3	5650 / 152.2	
	10 / 0.7	100 / 6.9	830 / 22.4	1280 / 34.7	3570 / 96.1	5070 / 136.6	9000 / 242.2	7390 / 198.9	
		15 / 1.0	220 / 6.1	410 / 11	830 / 22.5	1310 / 35.3	3130 / 84.3	5030 / 135.5	
		20 / 1.4	280 / 7.7	510 / 13.9	1090 / 29.6	1590 / 42.9	3740 / 100.7	6920 / 186.2	
		30 / 2.1	360 / 9.8	630 / 17.1	1370 / 37.1	1910 / 51.4	3140 / 84.7	8760 / 235.7	
		60 / 4.1	560 / 15.3	720 / 19.4	1800 / 48.7	2620 / 70.6	6360 / 171.2	7430 / 200.1	
		75 / 5.2	640 / 17.3	860 / 23.2	2660 / 71.7	3050 / 82.2	6840 / 184.1	7600 / 204.7	
		100 / 6.9	900 / 24.5	1730 / 46.8	3670 / 98.8	4680 / 126	8130 / 218.7	24600 / 664	
		150 / 10.3	1150 / 31	1990 / 53.5	5450 / 146.7	8400 / 226.2	21200 / 570.7	10200 / 275.6	
	20 / 1.4	200 / 13.8	1760 / 47.5	2870 / 77.3	7390 / 198.9	11600 / 312.2	27500 / 742.1	12800 / 346.2	
		300 / 20.7	2710 / 72.9	4880 / 131.4	10700 / 288.8	16200 / 438.4	28100 / 758		
		30 / 2.1	380 / 10.3	670 / 18.1	1360 / 36.8	2220 / 59.9	4980 / 134.2	9160 / 246.6	
		60 / 4.1	550 / 15	980 / 26.5	2130 / 57.5	2710 / 73	7820 / 210.6	13100 / 354.6	
		75 / 5.2	640 / 17.3	1150 / 31.1	2470 / 66.7	3590 / 96.7	8940 / 240.5	15400 / 416.8	
		100 / 6.9	990 / 26.7	1760 / 47.5	3610 / 97.3	6210 / 167.2	11400 / 308.9	24600 / 662.2	
		150 / 10.3	1410 / 38	2540 / 68.3	5680 / 153	9010 / 242.6	21200 / 571.7	13400 / 361.6	
		200 / 13.8	1820 / 49	3300 / 88.9	7400 / 199.1	11900 / 321.4	27500 / 741.1	14300 / 386.2	
	15 to 40 psig / 1.0 to 2.8 bar 10B3077X012 Green	40 / 2.8	300 / 20.7	2700 / 72.7	4950 / 133.3	10800 / 290.6	18200 / 492.1	30000 / 807.9	
			60 / 4.1	650 / 17.5	1050 / 28.5	2540 / 68.5	4060 / 109.4	9200 / 248.6	16300 / 439.3
75 / 5.2			790 / 21.3	1330 / 36	3040 / 81.8	4820 / 129.9	11000 / 297.3	19800 / 533	
100 / 6.9			1020 / 27.5	1720 / 46.5	3860 / 103.8	6150 / 165.6	13500 / 363.6	25500 / 688.4	
150 / 10.3			1470 / 39.8	2510 / 67.8	5580 / 150.3	9300 / 250.3	20300 / 547.8	28200 / 760.7	
200 / 13.8			1920 / 51.8	3300 / 88.9	7130 / 192	11900 / 321.5	26400 / 710.2	46400 / 1249.7	
35 to 80 psig / 2.4 to 5.5 bar 10B3078X012 Blue	60 / 4.1	300 / 20.7	2830 / 76.2	4860 / 130.8	10800 / 292.5	18000 / 484.8	39600 / 1067.7	63400 / 1706.6	
		75 / 5.2	720 / 19.5	1310 / 35.4	3030 / 81.6	4920 / 132.5	10800 / 293.1	18400 / 497.1	
		100 / 6.9	960 / 25.9	1740 / 46.8	3930 / 105.8	6190 / 166.6	13800 / 372.9	23700 / 638.3	
		150 / 10.3	1380 / 37.3	2480 / 66.9	5480 / 147.7	9020 / 242.9	20000 / 539.1	34200 / 922.1	
	80 / 5.5	200 / 13.8	1810 / 48.8	3160 / 85.2	6750 / 181.7	11700 / 316.1	26200 / 705.8	45300 / 1219.3	
		300 / 20.7	2690 / 72.4	4960 / 133.5	10600 / 285.2	17600 / 474.6	39000 / 1050	68400 / 1841.8	
		100 / 6.9	900 / 24.2	1670 / 45	3720 / 100.2	6140 / 165.4	13400 / 362.6	22900 / 618.2	
		150 / 10.3	1360 / 36.7	2510 / 67.6	5080 / 136.8	8020 / 216	19200 / 516.7	34300 / 924.2	
		200 / 13.8	1790 / 48.2	3270 / 88.1	5920 / 159.5	11300 / 306.6	25800 / 694.3	44900 / 1210.3	
		300 / 20.7	2660 / 71.6	4940 / 133.1	10400 / 282.1	17200 / 465.1	39000 / 1049.2	67600 / 1821.1	
70 to 150 psig / 4.8 to 10.3 bar 10B3079X012 Red	100 / 6.9	150 / 10.3	1380 / 37.2	2540 / 68.6	5460 / 147	8790 / 236.6	18600 / 501.1	31100 / 837.4	
		200 / 13.8	1850 / 49.8	2720 / 73.3	5930 / 159.7	8870 / 238.7	24000 / 646.4	39900 / 1075	
		300 / 20.7	2750 / 74.2	4690 / 126.3	9850 / 265.2	14700 / 397	36700 / 988.7	55200 / 1485.2	
	125 / 8.6	150 / 10.3	1390 / 37.6	2480 / 66.7	5520 / 148.6	8660 / 233.1	18700 / 505.2	30900 / 832.1	
		200 / 13.8	1860 / 50.2	3190 / 85.8	6740 / 181.3	11500 / 310.5	24500 / 661.7	39800 / 1072.3	
		300 / 20.7	2720 / 73.3	4900 / 131.9	9830 / 264.7	15600 / 422	37300 / 1003.9	58300 / 1568.4	
	150 / 10.3	200 / 13.8	1810 / 48.7	3120 / 84	7220 / 194.5	11400 / 306.8	24000 / 648	39600 / 1066.8	
		300 / 20.7	2730 / 73.5	4890 / 131.8	10600 / 286.1	16100 / 433.3	36400 / 979.6	60900 / 1639.4	

Blank areas indicate where maximum operating inlet pressure for a given orifice is exceeded.

1. Capacity is based on 20% droop unless otherwise noted below.

2. For pressure settings under 10 psig / 0.69 bar, inlet pressure should be limited to approximately 100 psig / 6.9 bar so the setpoint adjustment can be obtained.

3. For 5 psig / 0.34 bar pressure setpoint the droop is 2 psig / 0.14 bar.

627 Series

Table 9. Type 627 Capacities for NPS 2 / DN 50 Body Size⁽¹⁾⁽⁴⁾

OUTLET PRESSURE RANGE, SPRING PART NUMBER AND COLOR CODE	OUTLET PRESSURE SETTING ⁽²⁾ , psig / bar	INLET PRESSURE, psig / bar	CAPACITIES IN SCFH / Nm ³ /h OF 0.6 SPECIFIC GRAVITY NATURAL GAS					
			Orifice Size, In. / mm					
			3/32 / 2.4	1/8 / 3.2	3/16 / 4.8	1/4 / 6.4	3/8 / 9.5	1/2 / 13
5 to 20 psig / 0.34 to 1.4 bar 10B3076X012 Yellow	5 / 0.34 ⁽³⁾	10 / 0.69	170 / 4.6	330 / 8.8	710 / 19.0	1080 / 28.9	1700 / 45.6	2400 / 64.3
		15 / 1.0	240 / 6.4	390 / 10.5	890 / 23.9	1250 / 33.5	1900 / 50.9	2700 / 72.4
		20 / 1.4	290 / 7.8	500 / 13.4	1160 / 31.1	1900 / 50.9	2650 / 71.0	3900 / 105
		30 / 2.1	380 / 10.2	670 / 18.0	1560 / 41.8	2800 / 75.0	3680 / 98.6	6500 / 174
		60 / 4.1	640 / 17.2	1170 / 31.4	2600 / 69.7	4750 / 127	7250 / 194	17,800 / 477
		75 / 5.2	770 / 20.6	1410 / 37.8	3150 / 84.4	5700 / 153	8060 / 216	22,400 / 600
	10 / 0.69	15 / 1.0	210 / 5.6	375 / 10.1	880 / 23.6	1220 / 32.7	1860 / 49.8	2670 / 71.6
		20 / 1.4	280 / 7.5	490 / 13.1	1150 / 30.8	1880 / 50.4	2610 / 69.9	3830 / 103
		30 / 2.1	380 / 10.2	670 / 18.0	1560 / 41.8	2760 / 74.0	3640 / 97.6	6460 / 173
		60 / 4.1	640 / 17.2	1170 / 31.4	2600 / 69.7	4750 / 127	7250 / 194	17,800 / 477
		75 / 5.2	770 / 20.6	1410 / 37.8	3150 / 84.4	5700 / 153	8060 / 216	22,400 / 600
		100 / 6.9	990 / 26.5	1790 / 48.0	4070 / 109	7310 / 196	16,200 / 434	28,700 / 769
		150 / 10.3	1420 / 38.1	2580 / 69.1	5850 / 157	10,500 / 281	23,300 / 624	25,900 / 694
		200 / 13.8	1850 / 49.6	3370 / 90.3	7630 / 204	13,700 / 367	22,700 / 608	24,000 / 643
		300 / 20.7	2700 / 72.4	4910 / 132	11,200 / 300	10,300 / 276	12,800 / 343	
		500 / 34.5	4400 / 118	8090 / 217	18,300 / 490	21,000 / 563		
		750 / 51.7	6600 / 177	12,000 / 322	27,200 / 729			
		1000 / 69.0	8700 / 233	16,000 / 429				
		1250 / 86.2	11,000 / 295					
		1500 / 103	13,000 / 348					
	1750 / 121	15,000 / 402						
	2000 / 138	6300 / 169						
	20 / 1.4	30 / 2.1	350 / 9.4	620 / 16.6	1450 / 38.9	2350 / 63.0	4300 / 115	6110 / 164
		50 / 3.4	550 / 14.7	1000 / 26.8	2280 / 61.1	4040 / 108	7100 / 190	12,800 / 343
		60 / 4.1	640 / 17.2	1170 / 31.4	2640 / 70.8	4750 / 127	8400 / 225	15,700 / 421
		100 / 6.9	990 / 26.5	1800 / 48.2	4070 / 109	7310 / 196	16,200 / 434	28,700 / 769
		150 / 10.3	1420 / 38.1	2580 / 69.1	5850 / 157	10,500 / 281	23,300 / 624	29,000 / 777
		200 / 13.8	1850 / 49.6	3370 / 90.3	7630 / 204	13,700 / 367	24,000 / 643	33,000 / 884
		300 / 20.7	2700 / 72.4	4910 / 132	11,200 / 300	20,100 / 539	19,600 / 525	
		500 / 34.5	4400 / 118	8090 / 217	18,300 / 490	32,900 / 882		
		750 / 51.7	6600 / 177	12,000 / 322	27,200 / 729			
		1000 / 69.0	8700 / 233	16,000 / 429				
		1250 / 86.2	11,000 / 295					
		1500 / 103	13,000 / 348					
		1750 / 121	15,000 / 402					
		2000 / 138	6300 / 169					
15 to 40 psig / 1.0 to 2.8 bar 10B3077X012 Green	40 / 2.8	60 / 4.1	610 / 16.3	1090 / 29.2	2530 / 67.8	4370 / 117	8680 / 233	13,300 / 356
		75 / 5.2	760 / 20.4	1370 / 36.7	3080 / 82.5	5540 / 148	11,900 / 319	19,300 / 517
		100 / 6.9	990 / 26.5	1800 / 48.2	4070 / 109	7310 / 196	16,200 / 434	25,400 / 681
		150 / 10.3	1420 / 38.1	2580 / 69.1	5850 / 157	10,500 / 281	23,300 / 624	41,300 / 1107
		200 / 13.8	1850 / 49.6	3370 / 90.3	7630 / 204	13,700 / 367	30,400 / 815	53,900 / 1445
		300 / 20.7	2700 / 72.4	4910 / 132	11,200 / 300	20,100 / 539	44,600 / 1195	46,000 / 1233
		500 / 34.5	4400 / 118	8090 / 217	18,300 / 490	32,900 / 882	22,000 / 590	
		750 / 51.7	6600 / 177	12,000 / 322	27,200 / 729	28,000 / 750		
		1000 / 69.0	8700 / 233	16,000 / 429	36,100 / 967			
		1250 / 86.2	11,000 / 295					
		1500 / 103	13,000 / 348					
		1750 / 121	15,000 / 402					
		2000 / 138	17,000 / 456					

Blank areas indicate where maximum operating inlet pressure for a given orifice is exceeded.

1. Capacity is based on 20% droop unless otherwise noted below.

2. For pressure settings under 10 psig / 0.69 bar, inlet pressure should be limited to approximately 100 psig / 6.9 bar so the setpoint adjustment can be obtained.

3. For 5 psig / 0.34 bar pressure setpoint the droop is 2 psig / 0.14 bar.

4. Capacity is reduced by 10% for Type 627OSX.

- continued -

Table 9. Type 627 Capacities for NPS 2 / DN 50 Body Size⁽¹⁾⁽²⁾ (continued)

OUTLET PRESSURE RANGE, SPRING PART NUMBER AND COLOR CODE	OUTLET PRESSURE SETTING, psig / bar	INLET PRESSURE, psig / bar	CAPACITIES IN SCFH / Nm ³ /h OF 0.6 SPECIFIC GRAVITY NATURAL GAS					
			Orifice Size, In. / mm					
			3/32 / 2.4	1/8 / 3.2	3/16 / 4.8	1/4 / 6.4	3/8 / 9.5	1/2 / 13
35 to 80 psig / 2.4 to 5.5 bar 10B3078X012 Blue	60 / 4.1	75 / 5.2	700 / 18.8	1260 / 33.8	2760 / 74.0	4900 / 131	9000 / 241	12,300 / 330
		100 / 6.9	970 / 26.0	1740 / 46.6	4010 / 107	7000 / 188	15,000 / 402	20,400 / 547
		150 / 10.3	1420 / 38.1	2580 / 69.1	5850 / 157	10,500 / 281	23,300 / 624	35,200 / 943
		200 / 13.8	1850 / 49.6	3370 / 90.3	7630 / 204	13,700 / 367	30,400 / 815	53,900 / 1445
		300 / 20.7	2700 / 72.4	4910 / 132	11,200 / 300	20,100 / 539	44,600 / 1195	79,000 / 2117
		500 / 34.5	4400 / 118	8090 / 217	18,300 / 490	32,900 / 882	73,000 / 1956	38,800 / 1040
		750 / 51.7	6600 / 177	12,000 / 322	27,200 / 729	48,900 / 1311	53,000 / 1420	32,000 / 858
		1000 / 69.0	8700 / 233	16,000 / 429	36,100 / 967	43,000 / 1152	52,000 / 1394	
		1250 / 86.2	11,000 / 295	19,000 / 509	45,000 / 1206	70,000 / 1876		
		1500 / 103	13,000 / 348	22,000 / 590	54,000 / 1447	43,000 / 1152		
	1750 / 121	15,000 / 402	25,000 / 670	26,000 / 697				
	2000 / 138	17,000 / 456	28,000 / 750					
	80 / 5.5	100 / 6.9	900 / 24.1	1630 / 43.7	3750 / 101	6400 / 172	12,800 / 343	20,400 / 547
		150 / 10.3	1410 / 37.8	2580 / 69.1	5850 / 157	10,500 / 281	23,300 / 624	41,300 / 1107
		200 / 13.8	1850 / 49.6	3370 / 90.3	7630 / 204	13,700 / 367	30,400 / 815	53,900 / 1445
		300 / 20.7	2700 / 72.4	4910 / 132	11,200 / 300	20,100 / 539	44,600 / 1195	79,000 / 2117
		500 / 34.5	4400 / 118	8090 / 217	18,300 / 490	32,900 / 882	73,000 / 1956	48,000 / 1286
		750 / 51.7	6600 / 177	12,000 / 322	27,200 / 729	48,900 / 1311	87,000 / 2332	44,000 / 1179
		1000 / 69.0	8700 / 233	16,000 / 429	36,100 / 967	65,000 / 1742	63,000 / 1688	
		1250 / 86.2	11,000 / 295	19,000 / 509	45,000 / 1206	63,000 / 1688		
1500 / 103		13,000 / 348	22,000 / 590	54,000 / 1447	86,000 / 2305			
1750 / 121		15,000 / 402	25,000 / 670	63,000 / 1688				
2000 / 138	17,000 / 456	28,000 / 750						
70 to 150 psig / 4.8 to 10.3 bar 10B3079X012 Red	100 / 6.9	150 / 10.3	1170 / 31.4	2510 / 67.3	5540 / 148	8600 / 230	16,000 / 429	22,000 / 590
		200 / 13.8	1850 / 49.6	3370 / 90.3	7630 / 204	13,700 / 367	22,000 / 590	33,000 / 884
		300 / 20.7	2700 / 72.4	4910 / 132	11,200 / 300	20,100 / 539	35,000 / 938	65,300 / 1750
		500 / 34.5	4400 / 118	8090 / 217	18,300 / 490	32,900 / 882	73,000 / 1956	129,000 / 3457
		750 / 51.7	6600 / 177	12,000 / 322	27,200 / 729	48,900 / 1311	108,000 / 2894	54,000 / 1447
		1000 / 69.0	8700 / 233	16,000 / 429	36,100 / 967	64,800 / 1737	82,000 / 2198	
		1250 / 86.2	11,000 / 295	19,000 / 509	45,000 / 1206	80,000 / 2144	110,000 / 2948	
		1500 / 103	13,000 / 348	22,000 / 590	54,000 / 1447	96,000 / 2573		
		1750 / 121	15,000 / 402	25,000 / 670	63,000 / 1688	112,000 / 3002		
	2000 / 138	17,000 / 456	28,000 / 750	71,000 / 1903				
	125 / 8.6	150 / 10.3	1250 / 33.5	2340 / 62.7	5340 / 143	8600 / 230	16,000 / 429	24,000 / 643
		200 / 13.8	1830 / 49.0	3320 / 89.0	7550 / 202	13,700 / 367	24,000 / 643	36,000 / 965
		300 / 20.7	2700 / 72.4	4910 / 132	11,200 / 300	20,100 / 539	39,000 / 1045	65,300 / 1750
		500 / 34.5	4400 / 118	8090 / 217	18,300 / 490	32,900 / 882	73,000 / 1956	129,000 / 3457
		750 / 51.7	6600 / 177	12,000 / 322	27,200 / 729	48,900 / 1311	108,000 / 2894	59,000 / 1581
		1000 / 69.0	8700 / 233	16,000 / 429	36,100 / 967	64,800 / 1737	58,000 / 1554	
		1250 / 86.2	11,000 / 295	19,000 / 509	45,000 / 1206	80,000 / 2144	75,000 / 2010	
		1500 / 103	13,000 / 348	22,000 / 590	54,000 / 1447	96,000 / 2573		
1750 / 121		15,000 / 402	25,000 / 670	63,000 / 1688	112,000 / 3002			
2000 / 138	17,000 / 456	28,000 / 750	71,000 / 1903					
150 / 10.3	200 / 13.8	1760 / 47.2	3200 / 85.8	7290 / 195	13,000 / 348	24,000 / 643	38,000 / 1018	
	300 / 20.7	2700 / 72.4	4910 / 132	11,200 / 300	20,100 / 539	44,600 / 1195	64,200 / 1721	
	500 / 34.5	4400 / 118	8090 / 217	18,300 / 490	32,900 / 882	73,000 / 1956	129,000 / 3457	
	750 / 51.7	6600 / 177	12,000 / 322	27,200 / 729	48,900 / 1311	108,000 / 2894	62,000 / 1662	
	1000 / 69.0	8700 / 233	16,000 / 429	36,100 / 967	64,800 / 1737	144,000 / 3859		
	1250 / 86.2	11,000 / 295	19,000 / 509	45,000 / 1206	80,000 / 2144	81,000 / 2171		
	1500 / 103	13,000 / 348	22,000 / 590	54,000 / 1447	96,000 / 2573			
	1750 / 121	15,000 / 402	25,000 / 670	63,000 / 1688	112,000 / 3002			
	2000 / 138	17,000 / 456	28,000 / 750	71,000 / 1903				

— Blank areas indicate where maximum operating inlet pressure for a given orifice is exceeded.
 1. Capacity is based on 20% droop unless otherwise noted below.
 2. Capacity is reduced by 10% for Type 627OSX.

627 Series

Table 10. Types 627M, 627MR, 627BM, 627BMR and 627BMOSX Capacities for NPS 2 / DN 50 Body Size^{(1)/(5)}

OUTLET PRESSURE RANGE, SPRING PART NUMBER AND COLOR CODE	OUTLET PRESSURE SETTING ⁽³⁾ , psig / bar	INLET PRESSURE, psig / bar	CAPACITIES IN SCFH / Nm ³ /h OF 0.6 SPECIFIC GRAVITY NATURAL GAS							
			Orifice Size, In. / mm							
			For All Types Except Types 627BM and 627BMR							For Types 627BM and 627BMR Only
			3/32 / 2.4	1/8 / 3.2	3/16 / 4.8	1/4 / 6.4	3/8 / 9.5	1/2 / 13	9/16 / 14.3 ⁽²⁾	
5 to 20 psig / 0.34 to 1.4 bar 10B3076X012 Yellow	5 / 0.34 ⁽⁴⁾	10 / 0.69	170 / 4.6	330 / 8.8	710 / 19.0	1080 / 28.9	1700 / 45.6	2400 / 64.3	1700 / 45.5	
		15 / 1.0	240 / 6.4	390 / 10.5	890 / 23.9	1250 / 33.5	1900 / 50.9	2700 / 72.4	2250 / 60.3	
		20 / 1.4	290 / 7.8	500 / 13.4	1160 / 31.1	1900 / 50.9	2650 / 71.0	3900 / 105	2810 / 75.3	
		30 / 2.1	380 / 10.2	670 / 18.0	1560 / 41.8	2800 / 75.0	3680 / 98.6	6500 / 174	3800 / 102	
		60 / 4.1	640 / 17.2	1170 / 31.4	2600 / 69.7	4750 / 127	7250 / 194	15,000 / 402	6790 / 182	
		75 / 5.2	770 / 20.6	1410 / 37.8	3150 / 84.4	5700 / 153	8060 / 216	17,900 / 480	11,500 / 308	
	10 / 0.69	100 / 6.9	990 / 26.5	1790 / 48.0	4070 / 109	7310 / 196	14,600 / 391	23,000 / 616	19,400 / 520	
		15 / 1.0	210 / 5.6	375 / 10.1	880 / 23.6	1220 / 32.7	1860 / 49.8	2670 / 71.6	4330 / 116	
		20 / 1.4	280 / 7.5	490 / 13.1	1150 / 30.8	1880 / 50.4	2610 / 69.9	3830 / 103	5270 / 141	
		30 / 2.1	380 / 10.2	670 / 18.0	1560 / 41.8	2760 / 74.0	3640 / 97.6	6460 / 173	7150 / 192	
		60 / 4.1	640 / 17.2	1170 / 31.4	2600 / 69.7	4750 / 127	7250 / 194	15,000 / 402	12,700 / 340	
		75 / 5.2	770 / 20.6	1410 / 37.8	3150 / 84.4	5700 / 153	8060 / 216	17,900 / 480	13,400 / 359	
		100 / 6.9	990 / 26.5	1790 / 48.0	4070 / 109	7310 / 196	14,600 / 391	23,000 / 616	14,600 / 391	
		150 / 10.3	1420 / 38.1	2580 / 69.1	5850 / 157	10,500 / 281	21,000 / 563	33,000 / 884	16,800 / 450	
		200 / 13.8	1850 / 49.6	3370 / 90.3	7630 / 204	13,700 / 367	27,300 / 732	43,000 / 1152	22,600 / 605	
		300 / 20.7	2700 / 72.4	4910 / 132	11,200 / 300	20,100 / 539	40,100 / 1075		34,300 / 919	
		500 / 34.5	4400 / 118	8090 / 217	18,300 / 490	32,900 / 882			43,800 / 1173	
		750 / 51.7	6600 / 177	12,000 / 322	27,200 / 729				63,400 / 1698	
		1000 / 69.0	8700 / 233	16,000 / 429					83,000 / 2224	
		1250 / 86.2	11,000 / 295						100,200 / 2684	
	1500 / 103	13,000 / 348						117,400 / 3145		
	1750 / 121	15,000 / 402								
	2000 / 138	17,000 / 456								
	20 / 1.4	30 / 2.1	350 / 9.4	620 / 16.6	1450 / 38.9	2480 / 66.5	4300 / 115	6110 / 164	7800 / 209	
		50 / 3.4	550 / 14.7	1000 / 26.8	2280 / 61.1	4040 / 108	7100 / 190	12,800 / 343	13,400 / 359	
		60 / 4.1	640 / 17.2	1170 / 31.4	2640 / 70.8	4750 / 127	8400 / 225	15,000 / 402	16,100 / 431	
		100 / 6.9	990 / 26.5	1800 / 48.2	4070 / 109	7310 / 196	14,600 / 391	23,000 / 616	22,400 / 600	
		150 / 10.3	1420 / 38.1	2580 / 69.1	5850 / 157	10,500 / 281	21,000 / 563	33,000 / 884	30,200 / 809	
		200 / 13.8	1850 / 49.6	3370 / 90.3	7630 / 204	13,700 / 367	27,300 / 732	43,000 / 1152	32,700 / 876	
		300 / 20.7	2700 / 72.4	4910 / 132	11,200 / 300	20,100 / 539	40,100 / 1075		37,800 / 1013	
		500 / 34.5	4400 / 118	8090 / 217	18,300 / 490	32,900 / 882			67,600 / 1811	
		750 / 51.7	6600 / 177	12,000 / 322	27,200 / 729				93,800 / 2513	
		1000 / 69.0	8700 / 233	16,000 / 429					120,000 / 3215	
		1250 / 86.2	11,000 / 295						140,100 / 3753	
		1500 / 103	13,000 / 348						160,300 / 4294	
		1750 / 121	15,000 / 402							
2000 / 138		17,000 / 456								
15 to 40 psig / 1.0 to 2.8 bar 10B3077X012 Green	40 / 2.8	60 / 4.1	610 / 16.3	1090 / 29.2	2530 / 67.8	4370 / 117	8680 / 233	13,300 / 356	13,000 / 348	
		75 / 5.2	760 / 20.4	1370 / 36.7	3080 / 82.5	5540 / 148	10,700 / 287	19,300 / 517	18,700 / 501	
		100 / 6.9	990 / 26.5	1800 / 48.2	4070 / 109	7310 / 196	14,600 / 391	25,400 / 681	28,200 / 755	
		150 / 10.3	1420 / 38.1	2580 / 69.1	5850 / 157	10,500 / 281	21,000 / 563	37,000 / 992	47,200 / 1264	
		200 / 13.8	1850 / 49.6	3370 / 90.3	7630 / 204	13,700 / 367	27,300 / 732	48,000 / 1286	49,500 / 1326	
		300 / 20.7	2700 / 72.4	4910 / 132	11,200 / 300	20,100 / 539	40,100 / 1075	71,000 / 1903	54,100 / 1449	
		500 / 34.5	4400 / 118	8090 / 217	18,300 / 490	32,900 / 882	65,000 / 1742		93,200 / 2497	
		750 / 51.7	6600 / 177	12,000 / 322	27,200 / 729	48,900 / 1311			133,200 / 3568	
		1000 / 69.0	8700 / 233	16,000 / 429	36,100 / 967				173,100 / 4637	
		1250 / 86.2	11,000 / 295	19,000 / 509					198,900 / 5329	
		1500 / 103	13,000 / 348	22,000 / 590					224,600 / 6017	
		1750 / 121	15,000 / 402							
		2000 / 138	17,000 / 456							

Blank areas indicate where maximum operating inlet pressure for a given orifice is exceeded.
 Shaded areas indicate where a Type 627MR regulator should not be used because unbalanced forces can cause the internal relief valve to start-to-discharge during normal operation. Refer to Table 4.

- Capacity is based on 20% droop unless otherwise noted below.
- For Types 627BM and 627BMR only.
- For pressure settings under 10 psig / 0.69 bar, inlet pressure should be limited to approximately 100 psig / 6.9 bar so the setpoint adjustment can be obtained.
- For 5 psig / 0.34 bar pressure setpoint the droop is 2 psig / 0.14 bar.
- Capacity is reduced by 10% for Types 627MOSX and 627BMOSX.

- continued -

Table 10. Types 627M, 627MR, 627BM, 627BMR and 627BMOSX Capacities for NPS 2 / DN 50 Body Size⁽¹⁾⁽³⁾ (continued)

OUTLET PRESSURE RANGE, SPRING PART NUMBER AND COLOR CODE	OUTLET PRESSURE SETTING, psig / bar	INLET PRESSURE, psig / bar	CAPACITIES IN SCFH / Nm ³ /h OF 0.6 SPECIFIC GRAVITY NATURAL GAS							For Types 627BM and 627BMR Only
			Orifice Size, In. / mm							
			For All Types Except Types 627BM and 627BMR							
			3/32 / 2.4	1/8 / 3.2	3/16 / 4.8	1/4 / 6.4	3/8 / 9.5	1/2 / 13	9/16 / 14.3 ⁽²⁾	
35 to 80 psig / 2.4 to 5.5 bar 10B3078X012 Blue	60 / 4.1	75 / 5.2	700 / 18.8	1230 / 33.0	2760 / 74.0	4900 / 131	9000 / 241	12,300 / 330	15,000 / 402	
		100 / 6.9	970 / 26.0	1740 / 46.6	4010 / 107	7000 / 188	15,000 / 402	20,400 / 547	21,100 / 565	
		150 / 10.3	1420 / 38.1	2580 / 69.1	5850 / 157	10,500 / 281	23,300 / 624	35,200 / 943	33,400 / 895	
		200 / 13.8	1850 / 49.6	3370 / 90.3	7630 / 204	13,700 / 367	30,400 / 815	48,500 / 1300	45,700 / 1224	
		300 / 20.7	2700 / 72.4	4910 / 132	11,200 / 300	20,100 / 539	44,600 / 1195	71,000 / 1903	58,700 / 1573	
		500 / 34.5	4400 / 118	8090 / 217	18,300 / 490	32,900 / 882	73,000 / 1956	116,000 / 3109	95,100 / 2548	
		750 / 51.7	6600 / 177	12,000 / 322	27,200 / 729	48,900 / 1311	108,000 / 2894	172,000 / 4610	138,300 / 3705	
		1000 / 69.0	8700 / 233	16,000 / 429	36,100 / 967	65,000 / 1742	144,000 / 3859		181,500 / 4862	
		1250 / 86.2	11,000 / 295	19,000 / 509	45,000 / 1206	81,000 / 2171			208,600 / 5588	
		1500 / 103	13,000 / 348	22,000 / 590	54,000 / 1447	97,000 / 2600			235,600 / 6312	
	1750 / 121	15,000 / 402	25,000 / 670	63,000 / 1688						
	2000 / 138	17,000 / 456	28,000 / 750							
	80 / 5.5	100 / 6.9	900 / 24.1	1630 / 43.7	3750 / 101	6400 / 172	12,800 / 343	20,400 / 547	21,900 / 587	
		150 / 10.3	1410 / 37.8	2580 / 69.1	5850 / 157	10,500 / 281	23,300 / 624	37,200 / 997	37,900 / 1015	
		200 / 13.8	1850 / 49.6	3370 / 90.3	7630 / 204	13,700 / 367	30,400 / 815	48,500 / 1300	53,900 / 1444	
		300 / 20.7	2700 / 72.4	4910 / 132	11,200 / 300	20,100 / 539	44,600 / 1195	71,000 / 1903	65,200 / 1747	
		500 / 34.5	4400 / 118	8090 / 217	18,300 / 490	32,900 / 882	73,000 / 1956	116,000 / 3109	104,600 / 2802	
		750 / 51.7	6600 / 177	12,000 / 322	27,200 / 729	48,900 / 1311	108,000 / 2894	172,000 / 4610	147,100 / 3941	
		1000 / 69.0	8700 / 233	16,000 / 429	36,100 / 967	65,000 / 1742	144,000 / 3859		189,700 / 5082	
		1250 / 86.2	11,000 / 295	19,000 / 509	45,000 / 1206	81,000 / 2171			226,400 / 6065	
1500 / 103		13,000 / 348	22,000 / 590	54,000 / 1447	97,000 / 2600			263,100 / 7048		
1750 / 121		15,000 / 402	25,000 / 670	63,000 / 1688						
2000 / 138	17,000 / 456	28,000 / 750								
70 to 150 psig / 4.8 to 10.3 bar 10B3079X012 Red	100 / 6.9	150 / 10.3	1170 / 31.4	2510 / 67.3	5540 / 148	8600 / 230	16,000 / 429	22,000 / 590	28,100 / 753	
		200 / 13.8	1850 / 49.6	3370 / 90.3	7630 / 204	13,700 / 367	22,000 / 590	33,000 / 884	38,600 / 1034	
		300 / 20.7	2700 / 72.4	4910 / 132	11,200 / 300	20,100 / 539	35,000 / 938	59,000 / 1581	59,700 / 1599	
		500 / 34.5	4400 / 118	8090 / 217	18,300 / 490	32,900 / 882	73,000 / 1956	116,000 / 3109	91,100 / 2441	
		750 / 51.7	6600 / 177	12,000 / 322	27,200 / 729	48,900 / 1311	108,000 / 2894	172,000 / 4610	125,400 / 3359	
		1000 / 69.0	8700 / 233	16,000 / 429	36,100 / 967	64,800 / 1737	144,000 / 3859		159,800 / 4281	
		1250 / 86.2	11,000 / 295	19,000 / 509	45,000 / 1206	80,000 / 2144	179,000 / 4797		184,900 / 4953	
		1500 / 103	13,000 / 348	22,000 / 590	54,000 / 1447	96,000 / 2573			210,000 / 5626	
		1750 / 121	15,000 / 402	25,000 / 670	63,000 / 1688	112,000 / 3002				
		2000 / 138	17,000 / 456	28,000 / 750	71,000 / 1903					
	125 / 8.6	150 / 10.3	1250 / 33.5	2340 / 62.7	5340 / 143	8600 / 230	16,000 / 429	24,000 / 643	30,200 / 809	
		200 / 13.8	1830 / 49.0	3320 / 89.0	7550 / 202	13,700 / 367	24,000 / 643	36,000 / 965	41,600 / 1114	
		300 / 20.7	2700 / 72.4	4910 / 132	11,200 / 300	20,100 / 539	39,000 / 1045	59,000 / 1581	64,400 / 1725	
		500 / 34.5	4400 / 118	8090 / 217	18,300 / 490	32,900 / 882	73,000 / 1956	116,000 / 3109	103,200 / 2765	
		750 / 51.7	6600 / 177	12,000 / 322	27,200 / 729	48,900 / 1311	108,000 / 2894	172,000 / 4610	137,900 / 3694	
		1000 / 69.0	8700 / 233	16,000 / 429	36,100 / 967	64,800 / 1737	144,000 / 3859		172,700 / 4627	
		1250 / 86.2	11,000 / 295	19,000 / 509	45,000 / 1206	80,000 / 2144	179,000 / 4797		191,300 / 5125	
		1500 / 103	13,000 / 348	22,000 / 590	54,000 / 1447	96,000 / 2573			209,800 / 5621	
		1750 / 121	15,000 / 402	25,000 / 670	63,000 / 1688	112,000 / 3002				
		2000 / 138	17,000 / 456	28,000 / 750	71,000 / 1903					
	150 / 10.3	200 / 13.8	1760 / 47.2	3200 / 85.8	7290 / 195	13,000 / 348	24,000 / 643	38,000 / 1018	45,300 / 1214	
		300 / 20.7	2700 / 72.4	4910 / 132	11,200 / 300	20,100 / 539	44,600 / 1195	58,000 / 1554	73,500 / 1969	
		500 / 34.5	4400 / 118	8090 / 217	18,300 / 490	32,900 / 882	73,000 / 1956	116,000 / 3109	102,200 / 2738	
		750 / 51.7	6600 / 177	12,000 / 322	27,200 / 729	48,900 / 1311	108,000 / 2894	172,000 / 4610	139,800 / 3745	
		1000 / 69.0	8700 / 233	16,000 / 429	36,100 / 967	64,800 / 1737	144,000 / 3859		177,400 / 4753	
		1250 / 86.2	11,000 / 295	19,000 / 509	45,000 / 1206	80,000 / 2144	179,000 / 4797		201,100 / 5387	
		1500 / 103	13,000 / 348	22,000 / 590	54,000 / 1447	96,000 / 2573			224,800 / 6022	
		1750 / 121	15,000 / 402	25,000 / 670	63,000 / 1688	112,000 / 3002				
2000 / 138	17,000 / 456	28,000 / 750	71,000 / 1903							

— Blank areas indicate where maximum operating inlet pressure for a given orifice is exceeded.
 — Shaded areas indicate where a Type 627MR regulator should not be used because unbalanced forces can cause the internal relief valve to start-to-discharge during normal operation. Refer to Table 4.
 1. Capacity is based on 20% droop unless otherwise noted below.
 2. For Types 627BM and 627BMR only.
 3. Capacity is reduced by 10% for Types 627MOSX and 627BMOSX.

627 Series

Table 11. Types 627H and 627HM Capacities for 3/4 NPT Body Size⁽¹⁾

OUTLET PRESSURE RANGE, SPRING PART NUMBER AND COLOR CODE	OUTLET PRESSURE SETTING, psig / bar	INLET PRESSURE, psig / bar	CAPACITIES IN SCFH / Nm ³ /h OF 0.6 SPECIFIC GRAVITY NATURAL GAS					
			Orifice Size, In. / mm					
			3/32 / 2.4	1/8 / 3.2	3/16 / 4.8	1/4 / 6.4	3/8 / 9.5	1/2 / 13
140 to 250 psig / 9.6 to 17.2 bar 10B3078X012 Blue	150 / 10.3	200 / 13.8	1760 / 47.2 ⁽²⁾	3200 / 85.8 ⁽²⁾	7290 / 195	11,500 / 308	21,600 / 579	31,000 / 831
		250 / 17.2	2260 / 60.6 ⁽²⁾	4100 / 110 ⁽²⁾	9200 / 247	15,400 / 413	28,600 / 766	40,000 / 1072
		300 / 20.7	2700 / 72.4	4910 / 132	11,200 / 300	19,300 / 517	31,000 / 831	46,000 / 1233
		400 / 27.6	3600 / 96.5	6500 / 174	14,800 / 397	24,700 / 662	40,000 / 1072	50,000 / 1340
		500 / 34.5	4400 / 118	8090 / 217	18,300 / 490	29,700 / 796	51,000 / 1367	
		750 / 51.7	6600 / 177	12,000 / 322	27,200 / 729	43,000 / 1152		
		1000 / 69.0	8700 / 233	16,000 / 429	36,100 / 967	57,000 / 1528		
		1250 / 86.2	11,000 / 295	19,000 / 509	45,000 / 1206			
		1500 / 103	13,000 / 348	22,000 / 590	54,000 / 1447			
	1750 / 121	15,000 / 402	25,000 / 670	63,000 / 1688				
	2000 / 138	17,000 / 456	28,000 / 750					
	200 / 13.8	250 / 17.2	2160 / 57.9 ⁽²⁾	3850 / 103 ⁽²⁾	8400 / 225	15,000 / 402	31,000 / 831	41,000 / 1099
		300 / 20.7	2700 / 72.4 ⁽²⁾	4910 / 132 ⁽²⁾	11,200 / 300	19,500 / 523	36,000 / 965	52,000 / 1394
		400 / 27.6	3600 / 96.5	6500 / 174	14,800 / 397	25,500 / 683	52,000 / 1394	68,000 / 1822
		500 / 34.5	4400 / 118	8090 / 217	18,300 / 490	31,000 / 831	61,000 / 1635	
		750 / 51.7	6600 / 177	12,000 / 322	27,200 / 729	45,500 / 1219		
		1000 / 69.0	8700 / 233	16,000 / 429	36,100 / 967	60,000 / 1608		
		1250 / 86.2	11,000 / 295	19,000 / 509	45,000 / 1206			
		1500 / 103	13,000 / 348	22,000 / 590	54,000 / 1447			
		1750 / 121	15,000 / 402	25,000 / 670	63,000 / 1688			
	2000 / 138	17,000 / 456	28,000 / 750					
	250 / 17.2	300 / 20.7	2500 / 67 ⁽²⁾	4500 / 121 ⁽²⁾	9900 / 265	18,500 / 496	37,000 / 992	52,000 / 1394
		400 / 27.6	3600 / 96.5 ⁽²⁾	6400 / 172 ⁽²⁾	14,300 / 383	26,000 / 697	55,000 / 1474	74,000 / 1983
		500 / 34.5	4400 / 118	8090 / 217	18,300 / 490	33,000 / 884	64,000 / 1715	87,000 / 2332
		750 / 51.7	6600 / 177	12,000 / 322	27,200 / 729	49,000 / 1313	93,000 / 2492	
		1000 / 69.0	8700 / 233	16,000 / 429	36,100 / 967	65,000 / 1742		
		1250 / 86.2	11,000 / 295	19,000 / 509	45,000 / 1206	81,000 / 2171		
		1500 / 103	13,000 / 348	22,000 / 590	54,000 / 1447			
		1750 / 121	15,000 / 402	25,000 / 670	63,000 / 1688			
		2000 / 138	17,000 / 456	28,000 / 750	71,000 / 1903			
240 to 500 psig / 16.5 to 34.5 bar 10B3079X012 Red	250 / 17.2	300 / 20.7	2500 / 67.0 ⁽²⁾	4500 / 121 ⁽²⁾	9300 / 249	14,000 / 375	25,000 / 670	37,000 / 992
		400 / 27.6	3600 / 96.5 ⁽²⁾	6400 / 172 ⁽²⁾	14,300 / 383	21,400 / 574	36,000 / 965	49,000 / 1313
		500 / 34.5	4400 / 118	8090 / 217	18,300 / 490	26,300 / 705	42,000 / 1126	62,000 / 1662
		750 / 51.7	6600 / 177	12,000 / 322	27,200 / 729	37,100 / 994	57,000 / 1528	
		1000 / 69.0	8700 / 233	16,000 / 429	36,100 / 967	47,400 / 1270		
		1250 / 86.2	11,000 / 295	19,000 / 509	45,000 / 1206	57,000 / 1528		
		1500 / 103	13,000 / 348	22,000 / 590	54,000 / 1447			
		1750 / 121	15,000 / 402	25,000 / 670	63,000 / 1688			
		2000 / 138	17,000 / 456	28,000 / 750	71,000 / 1903			
	300 / 20.7	350 / 24.1	2900 / 77.7 ⁽²⁾	5150 / 138 ⁽²⁾	11,300 / 303	18,400 / 493	31,000 / 831	45,000 / 1206
		400 / 27.6	3500 / 93.8 ⁽²⁾	6200 / 166 ⁽²⁾	13,700 / 367	23,400 / 627	40,000 / 1072	52,000 / 1394
		500 / 34.5	4400 / 118	8090 / 217	18,300 / 490	32,000 / 858	53,000 / 1420	67,000 / 1796
		750 / 51.7	6600 / 177	12,000 / 322	27,200 / 729	48,000 / 1286	80,000 / 2144	
		1000 / 69.0	8700 / 233	16,000 / 429	36,100 / 967	62,000 / 1662		
		1250 / 86.2	11,000 / 295	19,000 / 509	45,000 / 1206	79,000 / 2117		
		1500 / 103	13,000 / 348	22,000 / 590	54,000 / 1447			
		1750 / 121	15,000 / 402	25,000 / 670	63,000 / 1688			
		2000 / 138	17,000 / 456	28,000 / 750	71,000 / 1903			

— Blank areas indicate where maximum operating inlet pressure for a given orifice is exceeded.

1. Capacity is based on 20% droop unless otherwise noted below.

2. Small orifices and low pressure drops may cause the setpoint to shift ±15 psig / 1.0 bar.

- continued -

Table 11. Types 627H and 627HM Capacities for 3/4 NPT Body Size⁽¹⁾ (continued)

OUTLET PRESSURE RANGE, SPRING PART NUMBER AND COLOR CODE	OUTLET PRESSURE SETTING, psig / bar	INLET PRESSURE, psig / bar	CAPACITIES IN SCFH / Nm ³ /h OF 0.6 SPECIFIC GRAVITY NATURAL GAS					
			Orifice Size, In. / mm					
			3/32 / 2.4	1/8 / 3.2	3/16 / 4.8	1/4 / 6.4	3/8 / 9.5	1/2 / 13
240 to 500 psig / 16.5 to 34.5 bar 10B3079X012 Red	400 / 27.6	450 / 31.0	3600 / 96.5 ⁽²⁾	6400 ⁽²⁾ / 172 ⁽²⁾	14,000 / 375	25,000 / 670	47,000 / 1260	67,000 / 1796
		500 / 34.5	4400 / 118 ⁽²⁾	8090 ⁽²⁾ / 217 ⁽²⁾	18,300 / 490	32,000 / 858	54,000 / 1447	77,000 / 2064
		750 / 51.7	6600 / 177	12,000 / 322	27,200 / 729	49,000 / 1313	91,000 / 2439	
		1000 / 69.0	8700 / 233	16,000 / 429	36,100 / 967	65,000 / 1742		
		1250 / 86.2	11,000 / 295	19,000 / 509	45,000 / 1206	81,000 / 2171		
		1500 / 103	13,000 / 348	22,000 / 590	54,000 / 1447			
		1750 / 121	15,000 / 402	25,000 / 670	63,000 / 1688			
	2000 / 138	17,000 / 456	28,000 / 750	71,000 / 1903				
	500 / 34.5	550 / 37.9	4300 / 115 ⁽²⁾	7700 / 206 ⁽²⁾	16,800 / 450	33,000 / 884	62,000 / 1662	90,000 / 2412
		600 / 41.4	4900 / 131 ⁽²⁾	8800 / 236 ⁽²⁾	19,400 / 520	37,000 / 992	70,000 / 1876	104,000 / 2787
		750 / 51.7	6600 / 177	12,000 / 322	27,200 / 729	49,000 / 1313	88,000 / 2358	137,000 / 3672
		1000 / 69.0	8700 / 233	16,000 / 429	36,100 / 967	65,000 / 1742	130,000 / 3484	
		1250 / 86.2	11,000 / 295	19,000 / 509	45,000 / 1206	81,000 / 2171		
		1500 / 103	13,000 / 348	22,000 / 590	54,000 / 1447	97,000 / 2600		
1750 / 121		15,000 / 402	25,000 / 670	63,000 / 1688				
2000 / 138	17,000 / 456	28,000 / 750	71,000 / 1903					

Blank areas indicate where maximum operating inlet pressure for a given orifice is exceeded.

1. Capacity is based on 20% droop unless otherwise noted below.

2. Small orifices and low pressure drops may cause the setpoint to shift ±15 psig / 1.0 bar.

Table 12. Types 627H, 627HM, 627BHM, 627BHMOSX and 627HOSX Capacities for NPS 1 / DN 25 Body Size⁽¹⁾⁽³⁾

OUTLET PRESSURE RANGE, SPRING PART NUMBER AND COLOR CODE	OUTLET PRESSURE SETTING, psig / bar	INLET PRESSURE, psig / bar	CAPACITIES IN SCFH / Nm ³ /h OF 0.6 SPECIFIC GRAVITY NATURAL GAS						
			Orifice Size, In. / mm						
			For All Types Except Type 627BHM						For Type 627BHM Only
3/32 / 2.4	1/8 / 3.2	3/16 / 4.8	1/4 / 6.4	3/8 / 9.5	1/2 / 13	9/16 / 14.3 ⁽⁴⁾			
140 to 250 psig / 9.7 to 17.2 bar 10B3078X012 Blue	150 / 10.3	200 / 13.8	1760 / 47.2 ⁽²⁾	3200 / 85.8 ⁽²⁾	7290 / 195	11,500 / 308	21,600 / 579	31,000 / 831	29,500 / 790
		250 / 17.2	2260 / 60.6 ⁽²⁾	4100 / 110 ⁽²⁾	9200 / 247	15,400 / 413	28,600 / 766	40,000 / 1072	39,500 / 1058
		300 / 20.7	2700 / 72.4	4910 / 132	11,200 / 300	19,300 / 517	31,000 / 831	46,000 / 1233	49,400 / 1323
		400 / 27.6	3600 / 96.5	6500 / 174	14,800 / 397	25,000 / 670	40,000 / 1072	50,000 / 1340	71,300 / 1910
		500 / 34.5	4400 / 118	8090 / 217	18,300 / 490	32,000 / 858	51,000 / 1367		95,900 / 2569
		750 / 51.7	6600 / 177	12,000 / 322	27,200 / 729	46,000 / 1233			131,100 / 3512
		1000 / 69.0	8700 / 233	16,000 / 429	36,100 / 967	57,000 / 1528			166,200 / 4452
		1250 / 86.2	11,000 / 295	19,000 / 509	45,000 / 1206				183,000 / 4903
		1500 / 103	13,000 / 348	22,000 / 590	54,000 / 1447				199,700 / 5350
		1750 / 121	15,000 / 402	25,000 / 670	63,000 / 1688				
140 to 250 psig / 9.6 to 17.2 bar 10B3078X012 Blue	200 / 13.8	250 / 17.2	2160 / 57.9 ⁽²⁾	3850 / 103 ⁽²⁾	8400 / 225	15,000 / 402	31,000 / 831	41,000 / 1099	43,800 / 1173
		300 / 20.7	2700 / 72.4 ⁽²⁾	4910 / 132 ⁽²⁾	11,200 / 300	19,500 / 523	36,000 / 965	52,000 / 1394	56,000 / 1500
		400 / 27.6	3600 / 96.5	6500 / 174	14,800 / 397	26,500 / 710	52,000 / 1394	68,000 / 1822	80,200 / 2149
		500 / 34.5	4400 / 118	8090 / 217	18,300 / 490	33,000 / 884	61,000 / 1635		90,500 / 2424
		750 / 51.7	6600 / 177	12,000 / 322	27,200 / 729	49,000 / 1313			141,800 / 3799
		1000 / 69.0	8700 / 233	16,000 / 429	36,100 / 967	65,000 / 1742			193,100 / 5173
		1250 / 86.2	11,000 / 295	19,000 / 509	45,000 / 1206				217,600 / 5830
		1500 / 103	13,000 / 348	22,000 / 590	54,000 / 1447				242,200 / 6489
		1750 / 121	15,000 / 402	25,000 / 670	63,000 / 1688				
	250 / 17.2	300 / 20.7	2500 / 67.0 ⁽²⁾	4500 / 121 ⁽²⁾	9900 / 265	18,500 / 496	37,000 / 992	52,000 / 1394	57,200 / 1532
		400 / 27.6	3600 / 96.5 ⁽²⁾	6400 / 172 ⁽²⁾	14,300 / 383	26,000 / 697	55,000 / 1474	74,000 / 1983	84,200 / 2256
		500 / 34.5	4400 / 118	8090 / 217	18,300 / 490	33,000 / 884	64,000 / 1715	87,000 / 2332	98,000 / 2625
		750 / 51.7	6600 / 177	12,000 / 322	27,200 / 729	49,000 / 1313	93,000 / 2492		150,900 / 4043
		1000 / 69.0	8700 / 233	16,000 / 429	36,100 / 967	65,000 / 1742			203,900 / 5462
		1250 / 86.2	11,000 / 295	19,000 / 509	45,000 / 1206	81,000 / 2171			243,300 / 6518
		1500 / 103	13,000 / 348	22,000 / 590	54,000 / 1447				282,800 / 7576
		1750 / 121	15,000 / 402	25,000 / 670	63,000 / 1688				
		2000 / 138	17,000 / 456	28,000 / 750	71,000 / 1903				

Blank areas indicate where maximum operating inlet pressure for a given orifice is exceeded.

1. Capacity is based on 20% droop unless otherwise noted below.

2. Small orifices and low pressure drops may cause the setpoint to shift ±15 psig / 1.0 bar.

3. Capacity is reduced by 10% for Types 627HOSX and 627BHMOSX.

4. For Types 627BM and 627BMR only.

- continued -

627 Series

Table 12. Types 627H, 627HM, 627BHM, 627BHMOSX and 627HOSX Capacities for NPS 1 / DN 25 Body Size⁽¹⁾⁽³⁾ (continued)

OUTLET PRESSURE RANGE, SPRING PART NUMBER AND COLOR CODE	OUTLET PRESSURE SETTING, psig / bar	INLET PRESSURE, psig / bar	CAPACITIES IN SCFH / Nm ³ /h OF 0.6 SPECIFIC GRAVITY NATURAL GAS						
			Orifice Size, In. / mm						
			For All Types Except Type 627BHM						For Type 627BHM Only
			3/32 / 2.4	1/8 / 3.2	3/16 / 4.8	1/4 / 6.4	3/8 / 9.5	1/2 / 13	9/16 / 14.3 ⁽⁴⁾
240 to 500 psig / 16.5 to 34.5 bar 10B3079X012 Red	250 / 17.2	300 / 20.7	2500 / 67.0 ⁽²⁾	4500 / 121 ⁽²⁾	9300 / 249	14,000 / 375	25,000 / 670	37,000 / 992	40,200 / 1077
		400 / 27.6	3600 / 96.5 ⁽²⁾	6400 / 172 ⁽²⁾	14,300 / 383	21,400 / 574	36,000 / 965	49,000 / 1313	56,800 / 1522
		500 / 34.5	4400 / 118	8090 / 217	18,300 / 490	26,300 / 705	42,000 / 1126	62,000 / 1662	72,700 / 1948
		750 / 51.7	6600 / 177	12,000 / 322	27,200 / 729	37,100 / 994	57,000 / 1528		116,600 / 3124
		1000 / 69.0	8700 / 233	16,000 / 429	36,100 / 967	47,400 / 1270			160,600 / 4302
		1250 / 86.2	11,000 / 295	19,000 / 509	45,000 / 1206	57,000 / 1528			184,100 / 4932
		1500 / 103	13,000 / 348	22,000 / 590	54,000 / 1447				207,600 / 5562
	1750 / 121	15,000 / 402	25,000 / 670	63,000 / 1688					
	2000 / 138	17,000 / 456	28,000 / 750	71,000 / 1903					
	300 / 20.7	350 / 24.1	2900 / 77.7 ⁽²⁾	5150 / 138 ⁽²⁾	11,300 / 303	18,400 / 493	31,000 / 831	45,000 / 1206	51,600 / 1382
		400 / 27.6	3500 / 93.8 ⁽²⁾	6200 / 166 ⁽²⁾	13,700 / 367	23,400 / 627	40,000 / 1072	52,000 / 1394	61,500 / 1648
		500 / 34.5	4400 / 118	8090 / 217	18,300 / 490	32,000 / 858	53,000 / 1420	67,000 / 1796	78,700 / 2108
		750 / 51.7	6600 / 177	12,000 / 322	27,200 / 729	48,000 / 1286	80,000 / 2144		116,200 / 3113
		1000 / 69.0	8700 / 233	16,000 / 429	36,100 / 967	62,000 / 1662			153,700 / 4118
		1250 / 86.2	11,000 / 295	19,000 / 509	45,000 / 1206	79,000 / 2117			196,500 / 5264
		1500 / 103	13,000 / 348	22,000 / 590	54,000 / 1447				239,200 / 6408
	1750 / 121	15,000 / 402	25,000 / 670	63,000 / 1688					
	2000 / 138	17,000 / 456	28,000 / 750	71,000 / 1903					
	400 / 27.6	450 / 31.0	3600 / 96.5 ⁽²⁾	6400 / 172 ⁽²⁾	14,000 / 375	25,000 / 670	47,000 / 1260	67,000 / 1796	89,600 / 2400
		500 / 34.5	4400 / 118 ⁽²⁾	8090 / 217 ⁽²⁾	18,300 / 490	32,000 / 858	54,000 / 1447	77,000 / 2064	99,700 / 2671
		750 / 51.7	6600 / 177	12,000 / 322	27,200 / 729	49,000 / 1313	91,000 / 2439		149,900 / 4016
		1000 / 69.0	8700 / 233	16,000 / 429	36,100 / 967	65,000 / 1742			200,100 / 5361
		1250 / 86.2	11,000 / 295	19,000 / 509	45,000 / 1206	81,000 / 2171			238,600 / 6392
		1500 / 103	13,000 / 348	22,000 / 590	54,000 / 1447				277,000 / 7421
		1750 / 121	15,000 / 402	25,000 / 670	63,000 / 1688				
	2000 / 138	17,000 / 456	28,000 / 750	71,000 / 1903					
	500 / 34.5	550 / 37.9	4300 / 115 ⁽²⁾	7700 / 206 ⁽²⁾	16,800 / 450	33,000 / 884	62,000 / 1662	90,000 / 2412	109,000 / 2920
		600 / 41.4	4900 / 131 ⁽²⁾	8800 / 236 ⁽²⁾	19,400 / 520	37,000 / 992	70,000 / 1876	104,000 / 2787	117,800 / 3156
		750 / 51.7	6600 / 177	12,000 / 322	27,200 / 729	49,000 / 1313	88,000 / 2358	140,000 / 3752	144,300 / 3866
		1000 / 69.0	8700 / 233	16,000 / 429	36,100 / 967	65,000 / 1742	130,000 / 3484		188,400 / 5047
1250 / 86.2		11,000 / 295	19,000 / 509	45,000 / 1206	81,000 / 2171			241,100 / 6459	
1500 / 103		13,000 / 348	22,000 / 590	54,000 / 1447	97,000 / 2600			293,800 / 7871	
1750 / 121		15,000 / 402	25,000 / 670	63,000 / 1688					
2000 / 138	17,000 / 456	28,000 / 750	71,000 / 1903						

Blank areas indicate where maximum operating inlet pressure for a given orifice is exceeded.

- Capacity is based on 20% droop unless otherwise noted below.
- Small orifices and low pressure drops may cause the setpoint to shift ±15 psig / 1.0 bar.
- Capacity is reduced by 10% for Types 627HOSX and 627BHMOSX.
- For Types 627BM and 627BMR only.

Table 13. Types 627H, 627HM, 627BHM, 627BHMOSX and 627HOSX Capacities for NPS 2 / DN 50 Body Size⁽¹⁾⁽³⁾

OUTLET PRESSURE RANGE, SPRING PART NUMBER AND COLOR CODE	OUTLET PRESSURE SETTING, psig / bar	INLET PRESSURE, psig / bar	CAPACITIES IN SCFH / Nm ³ /h OF 0.6 SPECIFIC GRAVITY NATURAL GAS						
			Orifice Size, In. / mm						
			For All Types Except Type 627BHM						For Type 627BHM Only
			3/32 / 2.4	1/8 / 3.2	3/16 / 4.8	1/4 / 6.4	3/8 / 9.5	1/2 / 13	9/16 / 14.3 ⁽⁴⁾
140 to 250 psig / 9.6 to 17.2 bar 10B3078X012 Blue	150 / 10.3	200 / 13.8	1760 / 47.2 ⁽²⁾	3200 / 85.8 ⁽²⁾	7290 / 195	13,700 / 367	24,100 / 646	31,000 / 831	31,500 / 844
		250 / 17.2	2260 / 60.6 ⁽²⁾	4100 / 110 ⁽²⁾	9200 / 247	16,100 / 431	28,600 / 766	40,000 / 1072	40,400 / 1082
		300 / 20.7	2700 / 72.4	4910 / 132	11,200 / 300	19,300 / 517	31,000 / 831	46,000 / 1233	49,400 / 1323
		400 / 27.6	3600 / 96.5	6500 / 174	14,800 / 397	25,000 / 670	40,000 / 1072	50,000 / 1340	61,400 / 1645
		500 / 34.5	4400 / 118	8090 / 217	18,300 / 490	32,000 / 858			86,600 / 2320
		750 / 51.7	6600 / 177	12,000 / 322	27,200 / 729	48,000 / 1286			136,900 / 3668
		1000 / 69.0	8700 / 233	16,000 / 429	36,100 / 967	65,000 / 1742			187,300 / 5018
		1250 / 86.2	11,000 / 295	19,000 / 509	45,000 / 1206				202,700 / 5430
		1500 / 103	13,000 / 348	22,000 / 590	54,000 / 1447				218,100 / 5843
		1750 / 121	15,000 / 402	25,000 / 670	63,000 / 1688				
2000 / 138	17,000 / 456	28,000 / 750							

Blank areas indicate where maximum operating inlet pressure for a given orifice is exceeded.

- Capacity is based on 20% droop unless otherwise noted below.
- Small orifices and low pressure drops may cause the setpoint to shift ±15 psig / 1.0 bar.
- Capacity is reduced by 10% for Types 627HOSX and 627BHMOSX.
- For Types 627BM and 627BMR only.

- continued -

Table 13. Types 627H, 627HM, 627BHM, 627BHMOSX and 627HOSX Capacities for NPS 2 / DN 50 Body Size⁽¹⁾⁽³⁾ (continued)

OUTLET PRESSURE RANGE, SPRING PART NUMBER AND COLOR CODE	OUTLET PRESSURE SETTING, psig / bar	INLET PRESSURE, psig / bar	CAPACITIES IN SCFH / Nm ³ /h OF 0.6 SPECIFIC GRAVITY NATURAL GAS							
			Orifice Size, in. / mm							For Type 627BHM Only
			For All Types Except Type 627BHM							
			3/32 / 2.4	1/8 / 3.2	3/16 / 4.8	1/4 / 6.4	3/8 / 9.5	1/2 / 13	9/16 / 14.3 ⁽⁴⁾	
140 to 250 psig / 9.6 to 17.2 bar 10B3078X012 Blue	200 / 13.8	250 / 17.2	2160 / 57.9 ⁽²⁾	3850 / 103 ⁽²⁾	8400 / 225	16,100 / 431	33,000 / 884	41,000 / 1099	43,600 / 1168	
		300 / 20.7	2700 / 72.4 ⁽²⁾	4910 / 132 ⁽²⁾	11,200 / 300	20,100 / 539	36,000 / 965	52,000 / 1394	52,400 / 1404	
		400 / 27.6	3600 / 96.5	6500 / 174	14,800 / 397	26,500 / 710	52,000 / 1394	68,000 / 1822	70,200 / 1881	
		500 / 34.5	4400 / 118	8090 / 217	18,300 / 490	33,000 / 884	61,000 / 1635		87,900 / 2355	
		750 / 51.7	6600 / 177	12,000 / 322	27,200 / 729	49,000 / 1313			137,700 / 3689	
		1000 / 69.0	8700 / 233	16,000 / 429	36,100 / 967	65,000 / 1742			187,500 / 5023	
		1250 / 86.2	11,000 / 295	19,000 / 509	45,000 / 1206				215,200 / 5765	
		1500 / 103	13,000 / 348	22,000 / 590	54,000 / 1447				243,000 / 6510	
		1750 / 121	15,000 / 402	25,000 / 670	63,000 / 1688					
	2000 / 138	17,000 / 456	28,000 / 750							
	250 / 17.2	300 / 20.7	2500 / 67.0 ⁽²⁾	4500 / 121 ⁽²⁾	9900 / 265	18,500 / 496	37,000 / 992	75,000 / 2010	57,000 / 1527	
		400 / 27.6	3600 / 96.5 ⁽²⁾	6400 / 172 ⁽²⁾	14,300 / 383	26,000 / 697	55,000 / 1474	81,000 / 2171	79,800 / 2138	
		500 / 34.5	4400 / 118	8090 / 217	18,300 / 490	33,000 / 884	64,000 / 1715	95,000 / 2546	84,400 / 2261	
		750 / 51.7	6600 / 177	12,000 / 322	27,200 / 729	49,000 / 1313	102,000 / 2734		136,800 / 3665	
		1000 / 69.0	8700 / 233	16,000 / 429	36,100 / 967	65,000 / 1742			189,200 / 5069	
		1250 / 86.2	11,000 / 295	19,000 / 509	45,000 / 1206	81,000 / 2171			224,800 / 6022	
		1500 / 103	13,000 / 348	22,000 / 590	54,000 / 1447				260,400 / 6976	
		1750 / 121	15,000 / 402	25,000 / 670	63,000 / 1688					
2000 / 138		17,000 / 456	28,000 / 750	71,000 / 1903						
240 to 500 psig / 16.5 to 34.5 bar 10B3079X012 Red	250 / 17.2	300 / 20.7	2500 / 67.0 ⁽²⁾	4500 / 121 ⁽²⁾	9300 / 249	14,000 / 375	25,000 / 670	37,000 / 992	39,200 / 1050	
		400 / 27.6	3600 / 96.5 ⁽²⁾	6400 / 172 ⁽²⁾	14,300 / 383	21,400 / 574	36,000 / 965	49,000 / 1313	56,500 / 1514	
		500 / 34.5	4400 / 118	8090 / 217	18,300 / 490	26,300 / 705	42,000 / 1126	62,000 / 1662	73,700 / 1974	
		750 / 51.7	6600 / 177	12,000 / 322	27,200 / 729	37,100 / 994	57,000 / 1528		109,000 / 2920	
		1000 / 69.0	8700 / 233	16,000 / 429	36,100 / 967	47,400 / 1270			144,400 / 3868	
		1250 / 86.2	11,000 / 295	19,000 / 509	45,000 / 1206	57,000 / 1528			165,600 / 4436	
		1500 / 103	13,000 / 348	22,000 / 590	54,000 / 1447				186,700 / 5002	
		1750 / 121	15,000 / 402	25,000 / 670	63,000 / 1688					
		2000 / 138	17,000 / 456	28,000 / 750	71,000 / 1903					
	300 / 20.7	350 / 24.1	2900 / 77.7 ⁽²⁾	5150 / 138 ⁽²⁾	11,300 / 303	18,400 / 493	31,000 / 831	45,000 / 1206	49,300 / 1321	
		400 / 27.6	3500 / 93.8 ⁽²⁾	6200 / 166 ⁽²⁾	13,700 / 367	23,400 / 627	40,000 / 1072	52,000 / 1394	58,000 / 1554	
		500 / 34.5	4400 / 118	8090 / 217	18,300 / 490	32,000 / 858	53,000 / 1420	67,000 / 1796	71,200 / 1907	
		750 / 51.7	6600 / 177	12,000 / 322	27,200 / 729	48,000 / 1286	80,000 / 2144		114,900 / 3078	
		1000 / 69.0	8700 / 233	16,000 / 429	36,100 / 967	62,000 / 1662			158,600 / 4249	
		1250 / 86.2	11,000 / 295	19,000 / 509	45,000 / 1206	79,000 / 2117			198,600 / 5320	
		1500 / 103	13,000 / 348	22,000 / 590	54,000 / 1447				238,600 / 6392	
		1750 / 121	15,000 / 402	25,000 / 670	63,000 / 1688					
		2000 / 138	17,000 / 456	28,000 / 750	71,000 / 1903					
240 to 500 psig / 16.5 to 34.5 bar 10B3079X012 Red	400 / 27.6	450 / 31.0	3600 / 96.5 ⁽²⁾	6400 / 172 ⁽²⁾	14,000 / 375	25,000 / 670	47,000 / 1260	67,000 / 1796	75,800 / 2031	
		500 / 34.5	4400 / 118 ⁽²⁾	8090 / 217 ⁽²⁾	18,300 / 490	32,000 / 858	54,000 / 1447	77,000 / 2064	85,700 / 2296	
		750 / 51.7	6600 / 177	12,000 / 322	27,200 / 729	49,000 / 1313	91,000 / 2439		135,500 / 3630	
		1000 / 69.0	8700 / 233	16,000 / 429	36,100 / 967	65,000 / 1742			185,400 / 4967	
		1250 / 86.2	11,000 / 295	19,000 / 509	45,000 / 1206	81,000 / 2171			228,700 / 6127	
		1500 / 103	13,000 / 348	22,000 / 590	54,000 / 1447				271,900 / 7284	
		1750 / 121	15,000 / 402	25,000 / 670	63,000 / 1688					
		2000 / 138	17,000 / 456	28,000 / 750	71,000 / 1903					
		500 / 34.5	550 / 37.9	4300 / 115 ⁽²⁾	7700 / 206 ⁽²⁾	16,800 / 450	33,000 / 884	62,000 / 1662	90,000 / 2412	100,200 / 2684
	600 / 41.4		4900 / 131 ⁽²⁾	8800 / 236 ⁽²⁾	19,400 / 520	37,000 / 992	70,000 / 1876	104,000 / 2787	103,600 / 2775	
	750 / 51.7		6600 / 177	12,000 / 322	27,200 / 729	49,000 / 1313	88,000 / 2358	140,000 / 3752	113,900 / 3051	
	1000 / 69.0		8700 / 233	16,000 / 429	36,100 / 967	65,000 / 1742	130,000 / 3484		201,600 / 5401	
	1250 / 86.2		11,000 / 295	19,000 / 509	45,000 / 1206	81,000 / 2171			261,300 / 7000	
	1500 / 103		13,000 / 348	22,000 / 590	54,000 / 1447	97,000 / 2600			320,900 / 8597	
	1750 / 121		15,000 / 402	25,000 / 670	63,000 / 1688					
	2000 / 138		17,000 / 456	28,000 / 750	71,000 / 1903					

Blank areas indicate where maximum operating inlet pressure for a given orifice is exceeded.

- Capacity is based on 20% droop unless otherwise noted below.
- Small orifices and low pressure drops may cause the setpoint to shift ±15 psig / 1.0 bar.
- Capacity is reduced by 10% for Types 627HOSX and 627BHMOSX.
- For Types 627BM and 627BMR only.

627 Series

Table 14. Type 627R Capacities for 3/4 NPT Body Size⁽¹⁾

OUTLET PRESSURE RANGE, SPRING PART NUMBER AND COLOR CODE	OUTLET PRESSURE SETTING ⁽²⁾ , psig / bar	INLET PRESSURE, psig / bar	CAPACITIES IN SCFH / Nm ³ /h OF 0.6 SPECIFIC GRAVITY NATURAL GAS						
			Orifice Size, In. / mm						
			3/32 / 2.4	1/8 / 3.2	3/16 / 4.8	1/4 / 6.4	3/8 / 9.5	1/2 / 13	
5 to 20 psig / 0.34 to 1.4 bar 10B3076X012 Yellow	5 / 0.34	10 / 0.69	170 / 4.6	320 / 8.6	710 / 19.0	1050 / 28.1	1500 / 40.2	1850 / 49.6	
		15 / 1.0	240 / 6.4	330 / 8.8	810 / 21.7	1290 / 34.6	2100 / 56.3	2850 / 76.4	
		20 / 1.4	290 / 7.8	460 / 12.3	1090 / 29.2	1750 / 46.9	2750 / 73.7	3850 / 103	
		30 / 2.1	380 / 10.2	610 / 16.3	1470 / 39.4	2490 / 66.7	3600 / 96.5	4800 / 129	
		60 / 4.1	640 / 17.2	1170 / 31.4	2460 / 65.9	3690 / 98.9	5270 / 141	6120 / 164	
		75 / 5.2	770 / 20.6	1410 / 37.8	2880 / 77.2	4150 / 111	5760 / 154	6900 / 185	
	10 / 0.69	100 / 6.9	990 / 26.5	1690 / 45.3	3540 / 94.9	4790 / 128	6200 / 166	7600 / 204	
		15 / 1.0	210 / 5.6	320 / 8.6	800 / 21.4	1290 / 34.6	2100 / 56.3	2820 / 75.6	
		20 / 1.4	280 / 7.5	450 / 12.1	1070 / 28.7	1740 / 46.6	2700 / 72.4	3800 / 102	
		30 / 2.1	380 / 10.2	610 / 16.3	1470 / 39.4	2430 / 65.1	3550 / 95.1	4780 / 128	
		60 / 4.1	640 / 17.2	1170 / 31.4	2460 / 65.9	3690 / 98.9	5270 / 141	6120 / 164	
		75 / 5.2	770 / 20.6	1410 / 37.8	2880 / 77.2	4150 / 111	5760 / 154	6900 / 185	
		100 / 6.9	990 / 26.5	1690 / 45.3	3540 / 94.9	4790 / 128	6200 / 166	7600 / 204	
		150 / 10.3	1420 / 38.1	2430 / 65.1	4000 / 107	5680 / 152	6250 / 168	7630 / 204	
		200 / 13.8	1850 / 49.6	3070 / 82.3	4200 / 113	6200 / 166	6380 / 171	7680 / 206	
		300 / 20.7	2700 / 72.4	3970 / 106	4270 / 114	6250 / 168	6500 / 174		
		500 / 34.5	4010 / 107	4240 / 114	5640 / 151	6520 / 175			
		750 / 51.7	4400 / 118	5120 / 137	6400 / 172				
		1000 / 69.0	4450 / 119	6220 / 167					
		1250 / 86.2	4540 / 122						
	1500 / 103	4880 / 131							
	1750 / 121	5230 / 140							
	2000 / 138	5900 / 158							
	20 / 1.4	30 / 2.1	350 / 9.4	590 / 15.8	1390 / 37.3	2480 / 66.5	4350 / 117	4970 / 133	
		50 / 3.4	550 / 14.7	980 / 26.3	2240 / 60.0	4000 / 107	7450 / 200	8000 / 214	
		60 / 4.1	640 / 17.2	1170 / 31.4	2610 / 69.9	4680 / 125	7800 / 209	8900 / 239	
		100 / 6.9	990 / 26.5	1800 / 48.2	3980 / 107	6700 / 180	9750 / 261	10,400 / 279	
		150 / 10.3	1420 / 38.1	2580 / 69.1	5600 / 150	8790 / 236	10,000 / 268	10,800 / 289	
	5 to 20 psig / 0.34 to 1.4 bar 10B3076X012 Yellow	20 / 1.4	200 / 13.8	1850 / 49.6	3370 / 90.3	7050 / 189	9000 / 241	10,200 / 273	10,800 / 289
			300 / 20.7	2700 / 72.4	4910 / 132	7300 / 196	9500 / 255	10,500 / 281	
500 / 34.5			4400 / 118	5200 / 139	7400 / 198	9760 / 262			
750 / 51.7			6600 / 177	5360 / 144	8870 / 238				
1000 / 69.0			7300 / 196	6500 / 174					
1250 / 86.2			7500 / 201						
1500 / 103			7800 / 209						
1750 / 121			8400 / 225						
2000 / 138	8600 / 230								
15 to 40 psig / 1.0 to 2.8 bar 10B3077X012 Green	40 / 2.8	60 / 4.1	610 / 16.3	1090 / 29.2	2270 / 60.8	4230 / 113	8100 / 217	9100 / 244	
		75 / 5.2	760 / 20.4	1370 / 36.7	3080 / 82.5	5330 / 143	10,300 / 276	11,600 / 311	
		100 / 6.9	990 / 26.5	1790 / 48.0	4070 / 109	6840 / 183	11,900 / 319	13,400 / 359	
		150 / 10.3	1420 / 38.1	2580 / 69.1	5850 / 157	9320 / 250	13,500 / 362	13,800 / 370	
		200 / 13.8	1850 / 49.6	3370 / 90.3	7630 / 204	11,000 / 295	16,300 / 437	17,100 / 458	
		300 / 20.7	2700 / 72.4	4910 / 132	11,200 / 300	14,700 / 394	17,800 / 477		
		500 / 34.5	4400 / 118	8090 / 217	14,500 / 389	14,800 / 397			
		750 / 51.7	6600 / 177	10,800 / 289	14,800 / 397	14,900 / 399			
		1000 / 69.0	8700 / 233	13,100 / 351	16,300 / 437				
		1250 / 86.2	11,000 / 295	13,800 / 370					
		1500 / 103	12,000 / 322	14,000 / 375					
		1750 / 121	13,000 / 348						
		2000 / 138	14,000 / 375						

Blank areas indicate where maximum operating inlet pressure for a given orifice is exceeded.

1. Capacity is based on 20% droop unless otherwise noted below.

2. For pressure setting under 10 psig / 0.69 bar, inlet pressure should be limited to approximately 100 psig / 6.9 bar so that setpoint adjustment can be obtained.

- continued -

Table 14. Type 627R Capacities for 3/4 NPT Body Size⁽¹⁾ (continued)

OUTLET PRESSURE RANGE, SPRING PART NUMBER AND COLOR CODE	OUTLET PRESSURE SETTING, psig / bar	INLET PRESSURE, psig / bar	CAPACITIES IN SCFH / Nm ³ /h OF 0.6 SPECIFIC GRAVITY NATURAL GAS					
			Orifice Size, In. / mm					
			3/32 / 2.4	1/8 / 3.2	3/16 / 4.8	1/4 / 6.4	3/8 / 9.5	1/2 / 13
35 to 80 psig / 2.4 to 5.5 bar 10B3078X012 Blue	60 / 4.1	75 / 5.2	700 / 18.8	1230 / 33.0	2760 / 74.0	4700 / 126	8170 / 219	12,600 / 338
		100 / 6.9	970 / 26.0	1740 / 46.6	3910 / 105	6690 / 179	11,900 / 319	14,400 / 386
		150 / 10.3	1420 / 38.1	2580 / 69.1	5850 / 157	9740 / 261	15,700 / 421	18,700 / 501
		200 / 13.8	1850 / 49.6	3370 / 90.3	7630 / 204	12,400 / 332	18,400 / 493	21,200 / 568
		300 / 20.7	2700 / 72.4	4910 / 132	11,200 / 300	17,700 / 474	20,200 / 541	
		500 / 34.5	4400 / 118	8090 / 217	18,300 / 490	20,000 / 536		
		750 / 51.7	6600 / 177	12,000 / 322	18,900 / 507	21,400 / 574		
		1000 / 69.0	8700 / 233	16,000 / 429	19,000 / 509			
		1250 / 86.2	11,000 / 295	18,700 / 501				
		1500 / 103	13,000 / 348	19,000 / 509				
	1750 / 121	15,000 / 402	20,000 / 536					
	2000 / 138	17,000 / 456						
	80 / 5.5	100 / 6.9	900 / 24.1	1630 / 43.7	3570 / 95.7	6490 / 174	12,000 / 322	17,200 / 461
		150 / 10.3	1410 / 37.8	2580 / 69.1	5750 / 154	10,500 / 281	18,900 / 507	25,000 / 670
		200 / 13.8	1850 / 49.6	3370 / 90.3	7630 / 204	13,700 / 367	23,000 / 616	29,000 / 777
		300 / 20.7	2700 / 72.4	4910 / 132	11,200 / 300	20,100 / 539	26,000 / 697	
		500 / 34.5	4400 / 118	8090 / 217	18,300 / 490	29,000 / 777		
		750 / 51.7	6600 / 177	12,000 / 322	23,100 / 619	30,900 / 828		
		1000 / 69.0	8700 / 233	16,000 / 429	27,400 / 734			
		1250 / 86.2	11,000 / 295	19,000 / 509				
1500 / 103		13,000 / 348	22,000 / 590					
1750 / 121		15,000 / 402	25,000 / 670					
2000 / 138	17,000 / 456							
70 to 150 psig / 4.8 to 10.3 bar 10B3079X012 Red	100 / 6.9	150 / 10.3	1170 / 31.4	2510 / 67.3	5540 / 148	8310 / 223	15,500 / 415	20,300 / 544
		200 / 13.8	1850 / 49.6	3370 / 90.3	7630 / 204	12,000 / 322	20,100 / 539	25,700 / 689
		300 / 20.7	2700 / 72.4	4910 / 132	11,200 / 300	18,200 / 488		
		500 / 34.5	4400 / 118	8090 / 217	18,300 / 490			
		750 / 51.7	6600 / 177	12,000 / 322				
		1000 / 69.0	8700 / 233	16,000 / 429				
		1250 / 86.2	11,000 / 295					
		1500 / 103	13,000 / 348					
		1750 / 121	15,000 / 402					
		2000 / 138	17,000 / 456					
70 to 150 psig / 4.8 to 10.3 bar 10B3079X012 Red	125 / 8.6	150 / 10.3	1250 / 33.5	2330 / 62.4	5090 / 136	9130 / 245	15,700 / 421	20,800 / 557
		200 / 13.8	1830 / 49.0	3320 / 89.0	7360 / 197	13,160 / 353	22,400 / 600	28,600 / 766
		300 / 20.7	2700 / 72.4	4910 / 132	11,200 / 300	19,700 / 528		
		500 / 34.5	4400 / 118	8090 / 217	18,300 / 490			
		750 / 51.7	6600 / 177	12,000 / 322				
		1000 / 69.0	8700 / 233	16,000 / 429				
		1250 / 86.2	11,000 / 295					
		1500 / 103	13,000 / 348					
		1750 / 121	15,000 / 402					
		2000 / 138	17,000 / 456					
	150 / 10.3	200 / 13.8	1760 / 47.2	3200 / 85.8	7020 / 188	12,500 / 335	21,400 / 574	30,600 / 820
		300 / 20.7	2700 / 72.4	4910 / 132	11,200 / 300	17,200 / 461		
		500 / 34.5	4400 / 118	8090 / 217	18,300 / 490			
		750 / 51.7	6600 / 177	12,000 / 322				
		1000 / 69.0	8700 / 233	16,000 / 429				
		1250 / 86.2	11,000 / 295					
		1500 / 103	13,000 / 348					
		1750 / 121	15,000 / 402					
		2000 / 138	17,000 / 456					

Blank areas indicate where maximum operating inlet pressure for a given orifice is exceeded.
1. Capacity is based on 20% droop unless otherwise noted below.

627 Series

Table 15. Type 627R Capacities for NPS 1 and 2 / DN 25 and 50 Body Sizes⁽¹⁾

OUTLET PRESSURE RANGE, SPRING PART NUMBER AND COLOR CODE	OUTLET PRESSURE SETTING ⁽²⁾ , psig / bar	INLET PRESSURE, psig / bar	CAPACITIES IN SCFH / Nm ³ /h OF 0.6 SPECIFIC GRAVITY NATURAL GAS					
			Orifice Size, In. / mm					
			3/32 / 2.4	1/8 / 3.2	3/16 / 4.8	1/4 / 6.4	3/8 / 9.5	1/2 / 13
5 to 20 psig / 0.34 to 1.4 bar 10B3076X012 Yellow	5 / 0.34	10 / 0.69	170 / 4.6	330 / 8.8	710 / 19.0	1080 / 28.9	2000 / 53.6	2150 / 57.6
		15 / 1.0	240 / 6.4	390 / 10.5	890 / 23.9	1500 / 40.2	2350 / 63.0	3000 / 80.4
		20 / 1.4	290 / 7.8	500 / 13.4	1160 / 31.1	1900 / 50.9	2750 / 73.7	3900 / 105
		30 / 2.1	380 / 10.2	690 / 18.5	1500 / 40.2	2500 / 67.0	3600 / 96.5	4900 / 131
		60 / 4.1	640 / 17.2	1170 / 31.4	2460 / 65.9	3690 / 98.9	5650 / 151	6900 / 185
		75 / 5.2	770 / 20.6	1410 / 37.8	2880 / 77.2	4150 / 111	6450 / 173	7490 / 201
	10 / 0.69	100 / 6.9	990 / 26.5	1800 / 48.2	3540 / 94.9	5790 / 155	7520 / 202	8150 / 218
		15 / 1.0	210 / 5.6	390 / 10.5	840 / 22.5	1480 / 39.7	2300 / 61.6	2930 / 78.5
		20 / 1.4	280 / 7.5	500 / 13.4	1100 / 29.5	1880 / 50.4	2700 / 72.4	3830 / 103
		30 / 2.1	380 / 10.2	690 / 18.5	1500 / 40.2	2460 / 65.9	3550 / 95.1	4840 / 130
		60 / 4.1	640 / 17.2	1170 / 31.4	2460 / 65.9	3690 / 98.9	5650 / 151	6900 / 185
		75 / 5.2	770 / 20.6	1410 / 37.8	2880 / 77.2	4150 / 111	6450 / 173	7490 / 201
		100 / 6.9	990 / 26.5	1800 / 48.2	3540 / 94.9	4790 / 128	7520 / 202	8150 / 218
		150 / 10.3	1420 / 38.1	2580 / 69.1	4660 / 125	5680 / 152	9980 / 267	10,800 / 289
		200 / 13.8	1850 / 49.6	3370 / 90.3	5620 / 151	6360 / 170	11,000 / 295	12,900 / 346
		300 / 20.7	2700 / 72.4	4880 / 131	6890 / 185	7780 / 209	13,600 / 364	
		500 / 34.5	4400 / 118	6720 / 180	8570 / 230	11,600 / 311		
		750 / 51.7	5400 / 145	8850 / 237	9000 / 241			
		1000 / 69.0	5800 / 155	9500 / 255				
		1250 / 86.2	6300 / 169					
1500 / 103	6600 / 177							
1750 / 121	6800 / 182							
2000 / 138	7600 / 204							
5 to 20 psig / 0.34 to 1.4 bar 10B3076X012 Yellow	20 / 1.4	30 / 2.1	350 / 9.4	600 / 16.1	1390 / 37.3	2580 / 69.1	4350 / 117	6290 / 169
		50 / 3.4	550 / 14.7	1000 / 26.8	2250 / 60.3	4090 / 110	7600 / 204	8000 / 214
		60 / 4.1	640 / 17.2	1170 / 31.4	2630 / 70.5	4750 / 127	7800 / 209	10,600 / 284
		100 / 6.9	990 / 26.5	1800 / 48.2	4070 / 109	7310 / 196	10,800 / 289	13,400 / 359
		150 / 10.3	1420 / 38.1	2580 / 69.1	5720 / 153	10,300 / 276	13,500 / 362	14,000 / 375
		200 / 13.8	1850 / 49.6	3370 / 90.3	7050 / 189	10,500 / 281	14,000 / 375	14,400 / 386
		300 / 20.7	2700 / 72.4	4910 / 132	9250 / 248	10,800 / 289	14,900 / 399	
		500 / 34.5	4400 / 118	7830 / 210	11,800 / 316	13,300 / 356		
		750 / 51.7	6600 / 177	9000 / 241	12,000 / 322			
		1000 / 69.0	8700 / 233	9660 / 259				
		1250 / 86.2	10,000 / 268					
		1500 / 103	10,400 / 279					
1750 / 121	12,000 / 322							
2000 / 138	14,000 / 375							
15 to 40 psig / 1.0 to 2.8 bar 10B3077X012 Green	40 / 2.8	60 / 4.1	610 / 16.3	1090 / 29.2	2430 / 65.1	4510 / 121	9200 / 247	9400 / 252
		75 / 5.2	760 / 20.4	1370 / 36.7	3080 / 82.5	5640 / 151	10,800 / 289	16,300 / 437
		100 / 6.9	990 / 26.5	1790 / 48.0	4070 / 109	7310 / 196	13,500 / 362	17,600 / 472
		150 / 10.3	1420 / 38.1	2580 / 69.1	5850 / 157	10,500 / 281	18,000 / 482	22,200 / 595
		200 / 13.8	1850 / 49.6	3370 / 90.3	7630 / 204	11,000 / 295	21,400 / 574	24,600 / 659
		300 / 20.7	2700 / 72.4	4910 / 132	11,200 / 300	14,900 / 399	24,400 / 654	
		500 / 34.5	4400 / 118	8090 / 217	16,300 / 437	21,800 / 584		
		750 / 51.7	6600 / 177	12,000 / 322	20,200 / 541	23,600 / 632		
		1000 / 69.0	8700 / 233	16,000 / 429	23,200 / 622			
		1250 / 86.2	11,000 / 295	19,000 / 509				
		1500 / 103	13,000 / 348	21,000 / 563				
		1750 / 121	15,000 / 402					
2000 / 138	17,000 / 456							

Blank areas indicate where maximum operating inlet pressure for a given orifice is exceeded.

1. Capacity is based on 20% droop unless otherwise noted below.

2. For pressure setting under 10 psig / 0.69 bar, inlet pressure should be limited to approximately 100 psig / 6.9 bar so that setpoint adjustment can be obtained.

- continued -

Table 15. Type 627R Capacities for NPS 1 and 2 / DN 25 and 50 Body Sizes⁽¹⁾ (continued)

OUTLET PRESSURE RANGE, SPRING PART NUMBER AND COLOR CODE	OUTLET PRESSURE SETTING, psig / bar	INLET PRESSURE, psig / bar	CAPACITIES IN SCFH / Nm ³ /h OF 0.6 SPECIFIC GRAVITY NATURAL GAS					
			Orifice Size, In. / mm					
			3/32 / 2.4	1/8 / 3.2	3/16 / 4.8	1/4 / 6.4	3/8 / 9.5	1/2 / 13
35 to 80 psig / 2.4 to 5.5 bar 10B3078X012 Blue	60 / 4.1	75 / 5.2	700 / 18.8	1230 / 33.0	2760 / 74.0	4860 / 130	8600 / 230	12,800 / 343
		100 / 6.9	970 / 26.0	1740 / 46.6	3910 / 105	7000 / 188	12,500 / 335	16,700 / 448
		150 / 10.3	1420 / 38.1	2580 / 69.1	5850 / 157	10,500 / 281	16,800 / 450	23,000 / 616
		200 / 13.8	1850 / 49.6	3370 / 90.3	7630 / 204	13,700 / 367	20,900 / 560	27,700 / 742
		300 / 20.7	2700 / 72.4	4910 / 132	11,200 / 300	20,100 / 539	28,100 / 753	
		500 / 34.5	4400 / 118	8090 / 217	18,300 / 490	28,500 / 764		
		750 / 51.7	6600 / 177	12,000 / 322	22,800 / 611	29,500 / 791		
		1000 / 69.0	8700 / 233	16,000 / 429	26,800 / 718			
		1250 / 86.2	11,000 / 295	19,000 / 509				
		1500 / 103	13,000 / 348	22,000 / 590				
	1750 / 121	15,000 / 402	25,000 / 670					
	2000 / 138	17,000 / 456						
	80 / 5.5	100 / 6.9	900 / 24.1	1630 / 43.7	3570 / 95.7	6650 / 178	12,000 / 322	17,400 / 466
		150 / 10.3	1410 / 37.8	2580 / 69.1	5750 / 154	10,500 / 281	20,100 / 539	26,000 / 697
		200 / 13.8	1850 / 49.6	3370 / 90.3	7630 / 204	13,700 / 367	25,100 / 673	31,800 / 852
		300 / 20.7	2700 / 72.4	4910 / 132	11,200 / 300	20,100 / 539	32,600 / 874	
		500 / 34.5	4400 / 118	8090 / 217	18,300 / 490	30,300 / 812		
		750 / 51.7	6600 / 177	12,000 / 322	27,200 / 729	37,400 / 1002		
		1000 / 69.0	8700 / 233	16,000 / 429	33,300 / 892			
		1250 / 86.2	11,000 / 295	19,000 / 509				
1500 / 103		13,000 / 348	22,000 / 590					
1750 / 121		15,000 / 402	25,000 / 670					
2000 / 138	17,000 / 456							
70 to 150 psig / 4.8 to 10.3 bar 10B3079X012 Red	100 / 6.9	150 / 10.3	1170 / 31.4	2510 / 67.3	5540 / 148	8310 / 223	15,500 / 415	20,300 / 544
		200 / 13.8	1850 / 49.6	3370 / 90.3	7630 / 204	12,000 / 322	20,100 / 539	26,700 / 716
		300 / 20.7	2700 / 72.4	4910 / 132	11,200 / 300	18,200 / 488		
		500 / 34.5	4400 / 118	8090 / 217	18,300 / 490			
		750 / 51.7	6600 / 177	12,000 / 322				
		1000 / 69.0	8700 / 233	16,000 / 429				
		1250 / 86.2	11,000 / 295					
		1500 / 103	13,000 / 348					
		1750 / 121	15,000 / 402					
		2000 / 138	17,000 / 456					
	125 / 8.6	150 / 10.3	1250 / 33.5	2330 / 62.4	5090 / 136	9470 / 254	15,700 / 421	20,800 / 557
		200 / 13.8	1830 / 49.0	3320 / 89.0	7360 / 197	13,400 / 359	23,600 / 632	31,300 / 839
		300 / 20.7	2700 / 72.4	4910 / 132	11,200 / 300	19,700 / 528		
		500 / 34.5	4400 / 118	8090 / 217	18,300 / 490			
		750 / 51.7	6600 / 177	12,000 / 322				
		1000 / 69.0	8700 / 233	16,000 / 429				
		1250 / 86.2	11,000 / 295					
		1500 / 103	13,000 / 348					
		1750 / 121	15,000 / 402					
		2000 / 138	17,000 / 456					
150 / 10.3	200 / 13.8	1760 / 47.2	3200 / 85.8	7020 / 188	12,900 / 346	21,400 / 574	33,300 / 892	
	300 / 20.7	2700 / 72.4	4910 / 132	11,200 / 300	17,200 / 461			
	500 / 34.5	4400 / 118	8090 / 217	18,300 / 490				
	750 / 51.7	6600 / 177	12,000 / 322					
	1000 / 69.0	8700 / 233	16,000 / 429					
	1250 / 86.2	11,000 / 295						
	1500 / 103	13,000 / 348						
	1750 / 121	15,000 / 402						
2000 / 138	17,000 / 456							

Blank areas indicate where maximum operating inlet pressure for a given orifice is exceeded.
1. Capacity is based on 20% droop unless otherwise noted below.

627 Series

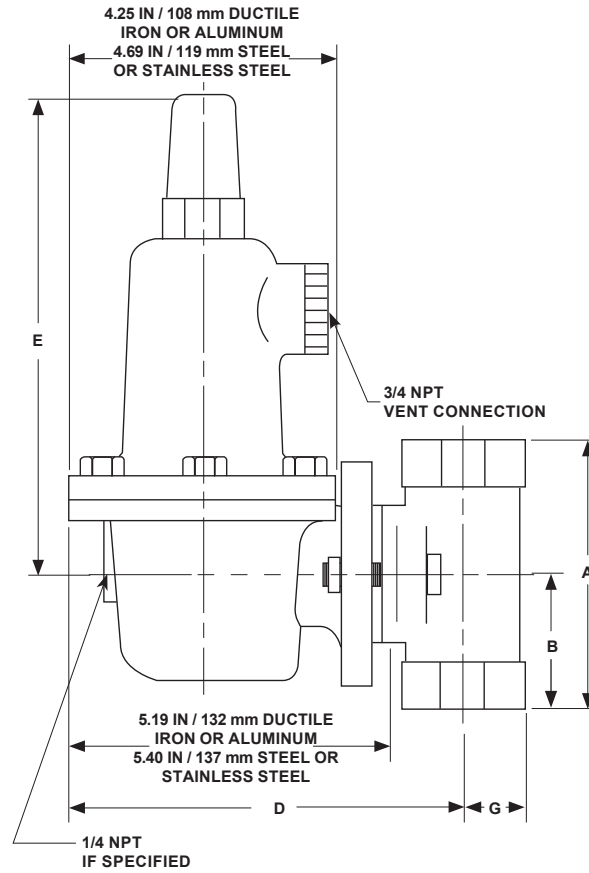

10B5885

Figure 14. NPT Dimensions

Table 16. Flow Coefficients

ORIFICE SIZE, IN. / mm	NPS 3/4 / DN 20 BODY			NPS 1 / DN 25 BODY			NPS 1-1/4 / DN 32 BODY			NPS 2 / DN 50 BODY		
	Wide-Open C_g for External Relief Sizing	Wide-Open C_v for External Relief Sizing	C_1	Wide-Open C_g for External Relief Sizing	Wide-Open C_v for External Relief Sizing	C_1	Wide-Open C_g for External Relief Sizing	Wide-Open C_v for External Relief Sizing	C_1	Wide-Open C_g for External Relief Sizing	Wide-Open C_v for External Relief Sizing	C_1
3/32 / 2.4	6.9	0.24	29.2	6.9	0.24	28.5	7.0	0.23	30.7	6.9	0.23	29.7
1/8 / 3.2	12.5	0.43	29.1	12.5	0.43	29.4	12.1	0.43	28.0	12.5	0.42	29.5
3/16 / 4.8	29	1.01	28.6	29	0.93	31.2	26	0.92	28.7	29	1.02	28.5
1/4 / 6.4	50	1.63	30.6	50	1.71	29.3	43	1.45	30.0	52	1.66	31.3
3/8 / 9.5	108	2.99	36.1	108	3.42	31.6	96	3.33	28.9	115	3.39	33.9
1/2 / 13	190	4.87	39.0	190	5.29	35.9	168	5.18	32.4	200	5.01	39.9
9/16 / 14.3	----	----	----	211.6	5.6	37.8	----	----	----	219.3	6.0	36.0

Table 17. IEC Sizing Coefficients

ORIFICE SIZE, IN. / mm	X_T			F_D	F_L
	NPS 3/4 / DN 20 Body	NPS 1 / DN 25 Body	NPS 2 / DN 50 Body		
3/32 / 2.4	0.539	0.514	0.558	0.50	0.85
1/8 / 3.2	0.536	0.547	0.539		0.79
3/16 / 4.8	0.517	0.616	0.514		0.85
1/4 / 6.4	0.592	0.543	0.620		0.87
3/8 / 9.5	0.824	0.632	0.727		0.89
1/2 / 13	0.962	0.815	1.01		0.86
9/16 / 14.3	----	0.906	0.823		0.89

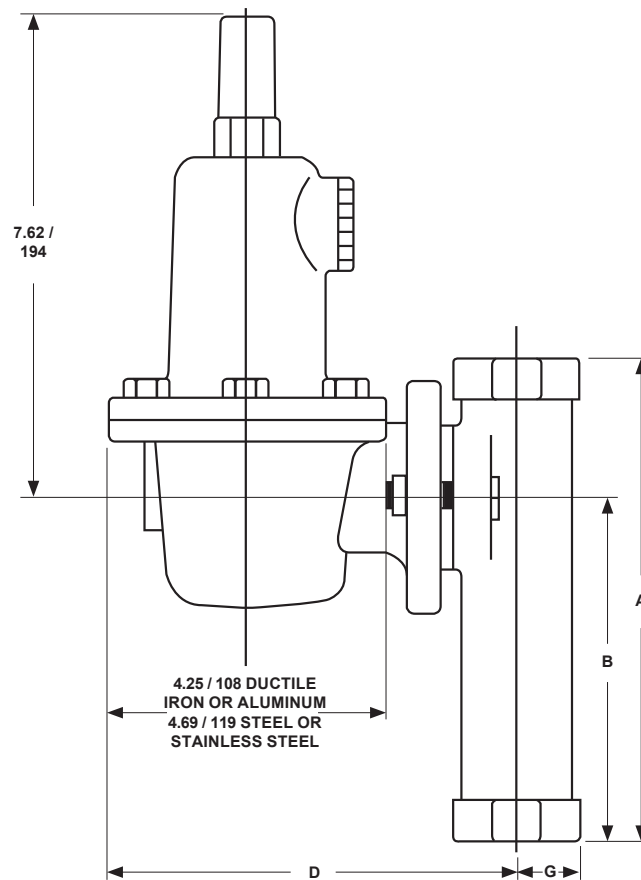

IN. /
mm

Figure 15. Long Body Dimensions

Table 18. NPT Body Dimensions

BODY SIZE, NPT	DIMENSION, IN. / mm						
	A	B	D		E		G
			Aluminum/ Ductile Iron	Steel/Stainless steel	Types 627, 627R, 627LR, 627M and 627MR	Types 627H and 627HM	
3/4 and 1	4.06 / 103	1.94 / 49.2	6.50 / 165	6.75 / 171	7.62 / 194	7.94 / 202	1.00 / 25.4
2	5.00 / 127	2.50 / 63.5	6.88 / 175	7.12 / 181			1.69 / 42.9

Table 19. Long Body Dimensions

BODY SIZE, NPT	DIMENSION, IN. / mm					
	A	B	D		G	
			Aluminum/ Ductile Iron	Steel/ Stainless Steel		
1	7.38 / 187	5.25 / 133	6.50 / 165	6.75 / 171	1.00 / 25.4	
2	7.88 / 200	5.38 / 137	6.88 / 175	7.12 / 181	1.69 / 42.9	

627 Series

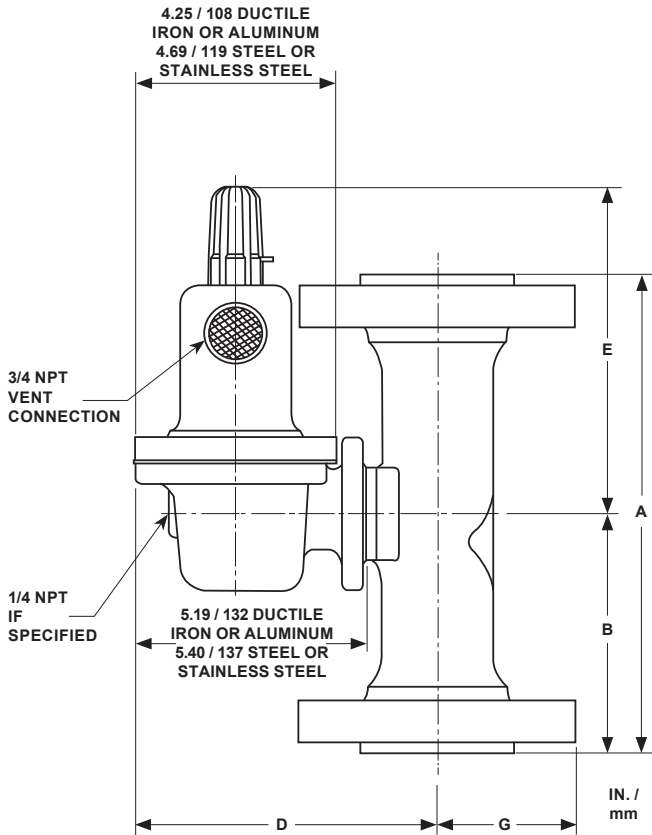

Figure 16. Flanged Dimensions

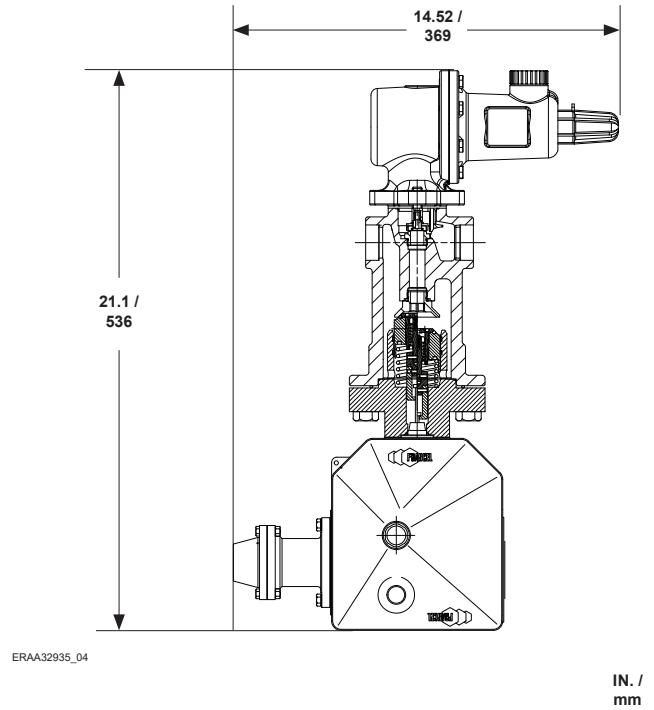

Figure 17. Type OSX Slam-Shut Valve Dimensions

Table 20. Flanged Body Dimensions

BODY SIZE, NPS / DN	DIMENSION, IN. / mm												
	A			B			D		E		G		
	CL150 RF	CL300 RF	CL600 RF	CL150 RF	CL300 RF	CL600 RF	Aluminum/Ductile Iron	Steel/Stainless Steel	Types 627, 627R, 627LR, 627M and 627MR	Types 627H and 627HM	CL150 RF	CL300 RF	CL600 RF
1 / 25	7.25 / 184	7.75 / 197	8.25 / 210	3.62 / 91.9	3.88 / 98.6	4.12 / 105	6.50 / 165	6.75 / 171	7.62 / 194	7.94 / 202	2.12 / 53.8	2.44 / 62.0	2.44 / 62.0
2 / 50	10 / 254	10.5 / 267	11.25 / 286	5 / 127	5.25 / 133	5.62 / 143	6.88 / 175	7.12 / 181			3 / 76.2	3.25 / 82.6	3.25 / 82.6

Ordering Information

Application

When ordering, specify:

1. Type of regulator
2. Body size
3. Body material and trim material
4. Orifice size in in. / mm
5. Control spring range in psig / bar

Construction

Refer to the Specifications section and to each referenced table; specify the desired selection whenever there is a choice to be made. The standard assembly position is 1D for NPT connection and 3D for flanged bodies, as shown in Figure 12, but an alternate assembly position may be factory-ordered or can be accomplished in the field by unbolting the body or spring case using the instructions in the appropriate section of the Instruction Manual. For installation dimensions, refer to Figures 15 to 18.

Ordering Guide

Type (Select One)

- 627 (basic construction)***
- 627H (high-pressure version)
(WCC steel/Stainless steel only)***
- 627M (external pressure registration)***
- 627BM***
- 627HM***
- 627BHM***
- 627R (internal relief)***
- 627LR***
- 627MR***
- 627BMR***
- 627BMOSX
- 627OSX

Body Size (Select One)

- 3/4 (NPT only)***
- NPS 1 / DN 25***
- NPS 1-1/4 / DN 32***
- NPS 2 / DN 50***
- 1 NPT Long Body**
- 2 NPT Long Body**

Body Material and End Connection Styles

(Select One)

Ductile Iron (not available for Types 627H and 627HM)

- NPT (available end connection for Type 627 long body)***

WCC steel (required for Types 627H, 627HM and 627BHM)

- NPT (available end connection for Type 627 long body)***
- CL150 RF**
- CL300 RF***
- CL600 RF***
- PN 16/25/40**
- BWE*

Stainless steel (Available only for Types 627, 627R and 627H)

- NPT***
- CL150 RF**
- CL300 RF***
- CL600 RF***
- PN 16/25/40**

Spring Case and Diaphragm Casing Material (Select One)

- Aluminum (Types 627, 627R and 627LR only)***
- Ductile iron***
- WCC steel***
- Stainless steel (Types 627, 627R and 627H only)***

Diaphragm Material (Select One)

- Nitrile (NBR)***
- Fluorocarbon (FKM)***
- Neoprene (CR) (For Types 627H, 627HM and 627BHM only)***

Trim Material (Select One)

- Aluminum (Types 627, 627R and 627LR only)***
- Stainless steel***

Valve Disk Material (Select One)

- Nitrile (NBR)***
- Nylon (PA) (not available to Type 627LR)***
- Fluorocarbon (FKM) (not available to Types 627BM, 627BMR, 627H, 627HM and 627BHM)**

Orifice Size (Select One)

- 3/32 in. / 2.4 mm***
- 1/8 in. / 3.2 mm***
- 3/16 in. / 4.8 mm***
- 1/4 in. / 6.4 mm***
- 3/8 in. / 9.5 mm (not available to Type 627LR)***
- 1/2 in. / 13 mm (not available to Type 627LR)***
- 9/16 in. / 14.3 mm (For Types 627BM, 627BMR, 627BHM, 627BMOSX and 627BHMOSX only)***

Outlet Pressure Range (Select One)

Types 627, 627M, 627BM, 627R and 627BMR

627 Series

Ordering Guide (continued)

- 5 to 20 psig / 0.34 to 1.4 bar, Yellow***
- 15 to 40 psig / 1.0 to 2.8 bar, Green***
- 35 to 80 psig / 2.4 to 5.5 bar, Blue***
- 70 to 150 psig / 4.8 to 10.3 bar, Red***

Type 627LR

- 15 to 40 psig / 1.0 to 2.8 bar, Green***

Types 627H, 627HM and 627BHM

- 140 to 250 psig / 9.7 to 17.2 bar, Blue***
- 240 to 500 psig / 16.5 to 34.5 bar, Red***

Body Position (Select One)

- Position 1 (standard for NPT connections)***
- Position 2**
- Position 3 (standard for flanged bodies)**
- Position 4**

Vent Position (Select One)

- Position C**
- Position D (standard)***
- Position E**
- Position F**

DVGW Approval Required (Optional)

- Yes*

Regulators Quick Order Guide	
***	Readily Available for Shipment
**	Allow Additional Time for Shipment
*	Special Order, Constructed from Non-Stocked Parts. Consult your local Sales Office for Availability.
Availability of the product being ordered is determined by the component with the longest shipping time for the requested construction.	

Replacement Parts Kit (Optional)

- Yes, send one replacement parts kit to match this order.

Specification Worksheet	
Application:	
Specific Use	_____
Line Size	_____
Gas Type and Specific Gravity	_____
Gas Temperature	_____
Does the Application Require Overpressure Protection?	
<input type="checkbox"/> Yes	<input type="checkbox"/> No If yes, which is preferred:
<input type="checkbox"/> Relief Valve <input type="checkbox"/> Monitor Regulator <input type="checkbox"/> Shutoff Device	
Is overpressure protection equipment selection assistance desired? _____	
Pressure:	
Maximum Inlet Pressure (P_{1max})	_____
Minimum Inlet Pressure (P_{1min})	_____
Downstream Pressure Setting(s) (P_2)	_____
Maximum Flow (Q_{max})	_____
Performance Required:	
Accuracy Requirements?	_____
Need for Extremely Fast Response?	_____
Other Requirements: _____	

 Webadmin.Regulators@emerson.com

 Facebook.com/EmersonAutomationSolutions

 Fisher.com

 LinkedIn.com/company/emerson-automation-solutions

 Twitter.com/emr_automation

Emerson Automation Solutions

Americas

McKinney, Texas 75070 USA
T +1 800 558 5853
+1 972 548 3574

Europe

Bologna 40013, Italy
T +39 051 419 0611

Asia Pacific

Singapore 128461, Singapore
T +65 6777 8211

Middle East and Africa

Dubai, United Arab Emirates
T +971 4 811 8100

D101331X012 © 1966, 2022 Emerson Process Management Regulator Technologies, Inc. All rights reserved. 10/22.

The Emerson logo is a trademark and service mark of Emerson Electric Co. All other marks are the property of their prospective owners. Fisher™ is a mark owned by Fisher Controls International LLC, a business of Emerson Automation Solutions.

The contents of this publication are presented for informational purposes only, and while every effort has been made to ensure their accuracy, they are not to be construed as warranties or guarantees, express or implied, regarding the products or services described herein or their use or applicability. All sales are governed by our terms and conditions, which are available upon request. We reserve the right to modify or improve the designs or specifications of such products at any time without notice.

Emerson Process Management Regulator Technologies, Inc does not assume responsibility for the selection, use or maintenance of any product. Responsibility for proper selection, use and maintenance of any Emerson Process Management Regulator Technologies, Inc. product remains solely with the purchaser.

